

SECTION **SE**
SEAT

A
B
C

CONTENTS

BASIC INSPECTION	8	POWER WALK-IN FUNCTION : Component Parts Location	15	F
DIAGNOSIS AND REPAIR WORK FLOW	8	POWER WALK-IN FUNCTION : Component Description	15	G
WorkFlow	8	POWER SEAT FOR PASSENGER SIDE	17	
INSPECTION AND ADJUSTMENT	9	POWER SEAT FUNCTION	17	H
ADDITIONAL SERVICE WHEN REMOVING BATTERY NEGATIVE TERMINAL	9	POWER SEAT FUNCTION : System Diagram	17	
ADDITIONAL SERVICE WHEN REMOVING BATTERY NEGATIVE TERMINAL : Description	9	POWER SEAT FUNCTION : System Description.....	17	
ADDITIONAL SERVICE WHEN REMOVING BATTERY NEGATIVE TERMINAL : Special Repair Requirement	9	POWER SEAT FUNCTION : Component Parts Location	18	I
ADDITIONAL SERVICE WHEN REPLACING CONTROL UNIT	9	POWER SEAT FUNCTION : Component Description	19	SE
ADDITIONAL SERVICE WHEN REPLACING CONTROL UNIT : Description	9	POWER WALK-IN FUNCTION	19	
ADDITIONAL SERVICE WHEN REPLACING CONTROL UNIT : Special Repair Requirement	9	POWER WALK-IN FUNCTION : System Diagram.....	19	K
SYSTEM INITIALIZATION	9	POWER WALK-IN FUNCTION : System Description	19	
SYSTEM INITIALIZATION : Description	9	POWER WALK-IN FUNCTION : Component Parts Location	22	L
SYSTEM INITIALIZATION : Special Repair Requirement	9	POWER WALK-IN FUNCTION : Component Description	22	
SYSTEM DESCRIPTION	10	SIDE SUPPORT UNIT	24	M
POWER SEAT FOR DRIVER SIDE	10	System Description	24	
POWER SEAT FUNCTION	10	Component Parts Location	24	N
POWER SEAT FUNCTION : System Diagram	10	Component Description	24	
POWER SEAT FUNCTION : System Description...	10	HEATED SEAT	25	O
POWER SEAT FUNCTION : Component Parts Location	11	System Diagram	25	
POWER SEAT FUNCTION : Component Description	12	System Description	25	
POWER WALK-IN FUNCTION	12	Component Parts Location	26	
POWER WALK-IN FUNCTION : System Diagram...	12	Component Description	26	P
POWER WALK-IN FUNCTION : System Description	12	LUMBAR SUPPORT	27	
		System Description	27	
		Component Parts Location	27	
		Component Description	27	
		CLIMATE CONTROLLED SEAT	28	
		System Diagram	28	

D
E

F
G

H
I

J
K

L
M

N
O

P

System Description	28	SEATBACK	52
Component Parts Location	29	SEATBACK : Description	52
Component Description	29	SEATBACK : Component Function Check	52
DIAGNOSIS SYSTEM (DRIVER SEAT C/U)	31	SEATBACK : Diagnosis Procedure	52
CONSULT Function	31	SEATBACK : Component Inspection	54
DTC/CIRCUIT DIAGNOSIS	34	RECLINING SWITCH	55
U1000 CAN COMM CIRCUIT	34	DRIVER SIDE	55
Description	34	DRIVER SIDE : Description	55
DTC Logic	34	DRIVER SIDE : Component Function Check	55
Diagnosis Procedure	34	DRIVER SIDE : Diagnosis Procedure	55
Special Repair Requirement	34	DRIVER SIDE : Component Inspection	56
B2112 SLIDING MOTOR	35	PASSENGER SIDE	56
Description	35	PASSENGER SIDE : Description	56
DTC Logic	35	PASSENGER SIDE :	
Diagnosis Procedure	35	Component Function Check	56
B2113 RECLINING MOTOR	37	PASSENGER SIDE : Diagnosis Procedure	57
Description	37	PASSENGER SIDE : Component Inspection	58
DTC Logic	37	LIFTING SWITCH (FRONT)	59
Diagnosis Procedure	37	DRIVER SIDE	59
POWER SUPPLY AND GROUND CIRCUIT	39	DRIVER SIDE : Description	59
DRIVER SEAT CONTROL UNIT	39	DRIVER SIDE : Component Function Check	59
DRIVER SEAT CONTROL UNIT :		DRIVER SIDE : Diagnosis Procedure	59
Diagnosis Procedure	39	DRIVER SIDE : Component Inspection	60
PASSENGER SEAT CONTROL UNIT	39	PASSENGER SIDE	60
PASSENGER SEAT CONTROL UNIT :		PASSENGER SIDE : Description	60
Diagnosis Procedure	39	PASSENGER SIDE :	
HEATED SEAT CONTROL UNIT	41	Component Function Check	60
HEATED SEAT CONTROL UNIT : Diagnosis Pro-		PASSENGER SIDE : Diagnosis Procedure	61
cedure	41	PASSENGER SIDE : Component Inspection	62
HEATED SEAT SWITCH	43	LIFTING SWITCH (REAR)	63
HEATED SEAT SWITCH : Diagnosis Procedure ...	43	DRIVER SIDE	63
CLIMATE CONTROLLED SEAT CONTROL UNIT... 44	44	DRIVER SIDE : Description	63
CLIMATE CONTROLLED SEAT CONTROL UNIT		DRIVER SIDE : Component Function Check	63
: Diagnosis Procedure	44	DRIVER SIDE : Diagnosis Procedure	63
CLIMATE CONTROLLED SEAT CONTROL UNIT		DRIVER SIDE : Component Inspection	64
: Component Inspection	48	PASSENGER SIDE	64
SLIDING SWITCH	49	PASSENGER SIDE : Description	64
DRIVER SIDE	49	PASSENGER SIDE :	
DRIVER SIDE : Description	49	Component Function Check	64
DRIVER SIDE : Component Function Check	49	PASSENGER SIDE : Diagnosis Procedure	65
DRIVER SIDE : Diagnosis Procedure	49	PASSENGER SIDE : Component Inspection	66
DRIVER SIDE : Component Inspection	50	POWER SEAT SWITCH GROUND CIRCUIT ... 67	67
PASSENGER SIDE	50	DRIVER SIDE	67
PASSENGER SIDE : Description	50	DRIVER SIDE : Diagnosis Procedure	67
PASSENGER SIDE :		PASSENGER SIDE	67
Component Function Check	50	PASSENGER SIDE : Diagnosis Procedure	67
PASSENGER SIDE : Diagnosis Procedure	51	FORWARD SWITCH	69
PASSENGER SIDE : Component Inspection	52	DRIVER SIDE	69
		DRIVER SIDE : Description	69

DRIVER SIDE : Component Function Check69	DRIVER SIDE87	
DRIVER SIDE : Diagnosis Procedure69	DRIVER SIDE : Description87	A
DRIVER SIDE : Component Inspection70	DRIVER SIDE : Component Function Check87	
PASSENGER SIDE70	DRIVER SIDE : Diagnosis Procedure87	
PASSENGER SIDE : Description70	PASSENGER SIDE89	B
PASSENGER SIDE : Component Function Check70	PASSENGER SIDE : Description89	
PASSENGER SIDE : Diagnosis Procedure71	PASSENGER SIDE : Component Function Check89	C
PASSENGER SIDE : Component Inspection72	PASSENGER SIDE : Diagnosis Procedure89	
SEAT BELT BUCKLE SWITCH73	SLIDING MOTOR92	
DRIVER SIDE73	DRIVER SIDE92	D
DRIVER SIDE : Description73	DRIVER SIDE : Description92	
DRIVER SIDE : Component Function Check73	DRIVER SIDE : Component Function Check92	E
DRIVER SIDE : Diagnosis Procedure73	DRIVER SIDE : Diagnosis Procedure92	
DRIVER SIDE : Component Inspection74	PASSENGER SIDE93	
PASSENGER SIDE74	PASSENGER SIDE : Description93	F
PASSENGER SIDE : Description74	PASSENGER SIDE : Component Function Check93	
PASSENGER SIDE : Component Function Check74	PASSENGER SIDE : Diagnosis Procedure93	G
PASSENGER SIDE : Diagnosis Procedure75	RECLINING MOTOR95	
PASSENGER SIDE : Component Inspection76	DRIVER SIDE95	H
SLIDING LIMIT SWITCH77	DRIVER SIDE : Description95	
DRIVER SIDE77	DRIVER SIDE : Component Function Check95	
DRIVER SIDE : Description77	DRIVER SIDE : Diagnosis Procedure95	I
DRIVER SIDE : Component Function Check77	PASSENGER SIDE96	
DRIVER SIDE : Diagnosis Procedure77	PASSENGER SIDE : Description96	
DRIVER SIDE : Component Inspection78	PASSENGER SIDE : Component Function Check96	SE
PASSENGER SIDE78	PASSENGER SIDE : Diagnosis Procedure96	
PASSENGER SIDE : Description78	LIFTING MOTOR (FRONT)97	K
PASSENGER SIDE : Component Function Check78	DRIVER SIDE97	
PASSENGER SIDE : Diagnosis Procedure79	DRIVER SIDE : Description97	L
PASSENGER SIDE : Component Inspection80	DRIVER SIDE : Component Function Check97	
POWER WALK-IN SWITCH81	DRIVER SIDE : Diagnosis Procedure97	
DRIVER SIDE81	PASSENGER SIDE98	M
DRIVER SIDE : Description81	PASSENGER SIDE : Description98	
DRIVER SIDE : Component Function Check81	PASSENGER SIDE : Component Function Check98	N
DRIVER SIDE : Diagnosis Procedure81	PASSENGER SIDE : Diagnosis Procedure98	
DRIVER SIDE : Component Inspection82	LIFTING MOTOR (REAR)99	O
PASSENGER SIDE82	DRIVER SIDE99	
PASSENGER SIDE : Description82	DRIVER SIDE : Description99	
PASSENGER SIDE : Component Function Check82	DRIVER SIDE : Component Function Check99	P
PASSENGER SIDE : Diagnosis Procedure83	DRIVER SIDE : Diagnosis Procedure99	
PASSENGER SIDE : Component Inspection84	PASSENGER SIDE100	
DOOR SWITCH85	PASSENGER SIDE : Description100	
Description85	PASSENGER SIDE : Component Function Check ..100	
Component Function Check85	PASSENGER SIDE : Diagnosis Procedure100	
Diagnosis Procedure85		
SLIDING SENSOR87		

HEATED SEAT SWITCH	101	PASSENGER SIDE : Diagnosis Procedure	116
DRIVER SIDE	101	HEATED SEAT SWITCH INDICATOR	118
DRIVER SIDE : Description	101	DRIVER SIDE	118
DRIVER SIDE : Component Function Check	101	DRIVER SIDE : Description	118
DRIVER SIDE : Diagnosis Procedure	101	DRIVER SIDE : Component Function Check	118
DRIVER SIDE : Component Inspection	102	DRIVER SIDE : Diagnosis Procedure	118
PASSENGER SIDE	102	PASSENGER SIDE	118
PASSENGER SIDE : Description	102	PASSENGER SIDE : Description	118
PASSENGER SIDE :		PASSENGER SIDE :	
Component Function Check	102	Component Function Check	118
PASSENGER SIDE : Diagnosis Procedure	103	PASSENGER SIDE : Diagnosis Procedure	118
PASSENGER SIDE : Component Inspection	104	CLIMATE CONTROLLED SEAT SWITCH	120
HEATED SEAT RELAY	105	Description	120
Description	105	Component Function Check	120
Component Function Check	105	Diagnosis Procedure	120
Diagnosis Procedure	105	Component Inspection	122
Component Inspection	106	SEATBACK THERMAL ELECTRIC DEVICE	123
HEAT SENSOR	107	Description	123
DRIVER SIDE	107	Component Function Check	123
DRIVER SIDE : Description	107	Diagnosis Procedure	123
DRIVER SIDE : Component Function Check	107	SEATBACK THERMAL ELECTRIC DEVICE	
DRIVER SIDE : Diagnosis Procedure	107	SENSOR	125
DRIVER SIDE : Component Inspection	108	Description	125
PASSENGER SIDE	109	Diagnosis Procedure	125
PASSENGER SIDE : Description	109	SEAT CUSHION THERMAL ELECTRIC DE-	
PASSENGER SIDE : Component Function Check	109	VICE	127
..109		Description	127
PASSENGER SIDE : Diagnosis Procedure	109	Component Function Check	127
PASSENGER SIDE : Component Inspection	111	Diagnosis Procedure	127
SEAT CUSHION HEATER	112	SEAT CUSHION THERMAL ELECTRIC DE-	
DRIVER SIDE	112	VICE SENSOR	129
DRIVER SIDE : Description	112	Description	129
DRIVER SIDE : Component Function Check	112	Diagnosis Procedure	129
DRIVER SIDE : Diagnosis Procedure	112	CLIMATE CONTROLLED SEATBACK	
DRIVER SIDE : Component Inspection	113	BLOWER MOTOR	131
PASSENGER SIDE	113	Description	131
PASSENGER SIDE : Description	113	Component Function Check	131
PASSENGER SIDE :		Diagnosis Procedure	131
Component Function Check	113	CLIMATE CONTROLLED SEAT CUSHION	
PASSENGER SIDE : Diagnosis Procedure	113	BLOWER MOTOR	134
PASSENGER SIDE : Component Inspection	115	Description	134
SEATBACK HEATER	116	Component Function Check	134
DRIVER SIDE	116	Diagnosis Procedure	134
DRIVER SIDE : Description	116	CLIMATE CONTROLLED SEAT SWITCH IN-	
DRIVER SIDE : Component Function Check	116	DICATOR	137
DRIVER SIDE : Diagnosis Procedure	116	Description	137
PASSENGER SIDE	116	Component Function Check	137
PASSENGER SIDE : Description	116	Diagnosis Procedure	137
PASSENGER SIDE :			
Component Function Check	116		

CLIMATE CONTROLLED SEAT BLOWER FILTER	139	SLIDING FUNCTION DOES NOT OPERATE .	167	A
SEATBACK BLOWER MOTOR	139	DRIVER SIDE	167	
SEATBACK BLOWER MOTOR : Diagnosis Procedure	139	DRIVER SIDE : Diagnosis Procedure	167	B
SEAT CUSHION BLOWER MOTOR	139	PASSENGER SIDE	167	
SEAT CUSHION BLOWER MOTOR : Diagnosis Procedure	139	PASSENGER SIDE : Diagnosis Procedure	167	C
LUMBAR SUPPORT	140	RECLINING FUNCTION DOES NOT OPERATE	169	
Wiring Diagram - LUMBAR SUPPORT -	140	DRIVER SIDE	169	D
SIDE SUPPORT	141	DRIVER SIDE : Diagnosis Procedure	169	
Wiring Diagram - SIDE SUPPORT -	141	PASSENGER SIDE	169	E
ECU DIAGNOSIS INFORMATION	142	PASSENGER SIDE : Diagnosis Procedure	169	
DRIVER SEAT CONTROL UNIT (WITHOUT AUTOMATIC DRIVE POSITIONER)	142	LIFTING FUNCTION DOES NOT OPERATE .	171	F
Reference Value	142	FRONT	171	
Wiring Diagram - POWER SEAT SYSTEM FOR DRIVER SIDE (WITHOUT AUTOMATIC DRIVE POSITIONER) -	144	FRONT : Diagnosis Procedure	171	G
Fail-Safe	146	REAR	171	
DTC Index	147	REAR : Diagnosis Procedure	171	H
PASSENGER SEAT CONTROL UNIT	149	POWER WALK-IN FUNCTION DOES NOT OPERATE	173	
Reference Value	149	DRIVER SIDE	173	I
Wiring Diagram - POWER SEAT SYSTEM FOR PASSENGER SIDE -	152	DRIVER SIDE : Diagnosis Procedure	173	
HEATED SEAT CONTROL UNIT	154	PASSENGER SIDE	174	SE
Reference Value	154	PASSENGER SIDE : Diagnosis Procedure	174	
Wiring Diagram - HEATED SEAT SYSTEM (WITH M/T) -	155	HEATED SEAT DOES NOT OPERATE	176	K
Wiring Diagram - HEATED SEAT SYSTEM (WITH A/T) -	157	BOTH SIDES	176	
CLIMATE CONTROLLED SEAT CONTROL UNIT	158	BOTH SIDES : Diagnosis Procedure	176	L
Reference Value	158	DRIVER SIDE	176	
Wiring Diagram - CLIMATE CONTROLLED SEAT CONTROL SYSTEM -	160	DRIVER SIDE : Diagnosis Procedure	176	M
Fail-safe	162	PASSENGER SIDE	177	
SYMPTOM DIAGNOSIS	165	PASSENGER SIDE : Diagnosis Procedure	177	N
ALL COMPONENTS OF POWER SEAT DO NOT OPERATE	165	SEATBACK HEATER ONLY DOES NOT OPERATE	178	
DRIVER SIDE	165	DRIVER SIDE	178	O
DRIVER SIDE : Diagnosis Procedure	165	DRIVER SIDE : Diagnosis Procedure	178	
PASSENGER SIDE	165	PASSENGER SIDE	178	P
PASSENGER SIDE : Diagnosis Procedure	165	PASSENGER SIDE : Diagnosis Procedure	178	
POWER SEAT SWITCH (PASSENGER SIDE) DOES NOT OPERATE ANY COMPONENTS..	166	CANNOT ADJUST HEATED SEAT TEMPERATURE	179	
Diagnosis Procedure	166	DRIVER SIDE	179	
		DRIVER SIDE : Diagnosis Procedure	179	
		PASSENGER SIDE	179	
		PASSENGER SIDE : Diagnosis Procedure	179	
		HEATED SEAT SWITCH INDICATOR DOES NOT TURN ON	180	

DRIVER SIDE	180	Service Procedure Precautions for Models with a Pop-up Roll Bar	195
DRIVER SIDE : Diagnosis Procedure	180	Precaution for Battery Service	195
PASSENGER SIDE	180	Service Notice	195
PASSENGER SIDE : Diagnosis Procedure	180	Precaution for Work	196
CLIMATE CONTROLLED SEAT DOES NOT OPERATE.	181	PREPARATION	197
DRIVER SIDE	181	PREPARATION	197
DRIVER SIDE : Diagnosis Procedure	181	Special Service Tool	197
PASSENGER SIDE	182	Commercial Service Tool	197
PASSENGER SIDE : Diagnosis Procedure	182	CLIP LIST	198
TEMPERATURE ADJUSTMENT IS IMPOSSI- BLE	183	Clip List	198
SEAT CUSHION BLOWER MOTOR	183	REMOVAL AND INSTALLATION	199
SEAT CUSHION BLOWER MOTOR : Description	183	FRONT SEAT	199
SEAT CUSHION BLOWER MOTOR : Diagnosis Procedure	183	Exploded View	199
SEAT CUSHION BLOWER MOTOR	183	Removal and Installation	210
SEAT CUSHION BLOWER MOTOR : Description	183	Disassembly and Assembly	211
SEAT CUSHION BLOWER MOTOR : Diagnosis Procedure	183	REAR SEAT	222
CLIMATE CONTROLLED SEAT DOES NOT OPERATES WHEN SWITCH IS DONE IN HEAT OR COOL.	185	Exploded View	222
Diagnosis Procedure	185	Removal and Installation	222
CLIMATE CONTROLLED SEAT ACTIVATES ONCE BUT STOPS IMMEDIATELY	186	Disassembly and Assembly	223
SEATBACK BLOWER MOTOR	186	DRIVER SEAT CONTROL UNIT	224
SEATBACK BLOWER MOTOR : Description	186	Exploded View	224
SEATBACK BLOWER MOTOR : Diagnosis Pro- cedure	186	Removal and Installation	224
SEAT CUSHION BLOWER MOTOR	186	PASSENGER SEAT CONTROL UNIT	225
SEAT CUSHION BLOWER MOTOR : Description	186	Exploded View	225
SEAT CUSHION BLOWER MOTOR : Diagnosis Procedure	186	Removal and Installation	225
SEAT SWITCH INDICATOR IS NOT ILLUMI- NATED IN HEAT OR COOL POSITION	188	HEATED SEAT CONTROL UNIT	226
Diagnosis Procedure	188	Exploded View	226
SQUEAK AND RATTLE TROUBLE DIAG- NOSES	189	Removal and Installation	226
Work Flow	189	POWER SEAT SWITCH	227
Inspection Procedure	191	Removal and Installation	227
Diagnostic Worksheet	193	SLIDING SWITCH	228
PRECAUTION	195	SEATBACK	228
PRECAUTIONS	195	SEATBACK : Removal and Installation	228
Precaution for Supplemental Restraint System (SRS) "AIR BAG" and "SEAT BELT PRE-TEN- SIONER"	195	SIDE SUPPORT SWITCH	229
		Removal and Installation	229
		LUMBAR SUPPORT SWITCH	230
		Removal and Installation	230
		HEATED SEAT SWITCH	231
		Exploded View	231
		Removal and Installation	231
		CLIMATE CONTROLLED SEAT SWITCH	232
		Exploded View	232
		Removal and Installation	232
		CLIMATE CONTROLLED SEAT BLOWER FILTER	233

SEAT CUSHION	233	SEATBACK	233
SEAT CUSHION : Exploded View	233	SEATBACK : Exploded View	233
SEAT CUSHION : Removal and Installation	233	SEATBACK : Removal and Installation	233

A
B
C
D
E
F
G
H
I

SE

K
L
M
N
O
P

DIAGNOSIS AND REPAIR WORK FLOW

< BASIC INSPECTION >

BASIC INSPECTION

DIAGNOSIS AND REPAIR WORK FLOW

WorkFlow

INFOID:000000008157939

DETAILED FLOW

1.OBTAIN INFORMATION ABOUT SYMPTOM

Interview the customer to obtain the malfunction information (conditions and environment when the malfunction occurred) as much as possible when the customer brings the vehicle in.

>> GO TO 2.

2.CHECK FOR DTC

1. Check DTC for BCM.
2. Perform the following procedure if DTC is displayed.
 - Record DTC and freeze frame data (Print them out with CONSULT.)
 - Erase DTC.
 - Study the relationship between the cause detected by DTC and the symptom described by the customer.
3. Check related service bulletins for information.

Is any symptom described and any DTC detected?

Symptom is described, DTC is displayed>>[SE-147, "DTC Index"](#).

Symptom is described, DTC is not displayed>>GO TO 3.

3.REPRODUCE THE MALFUNCTION INFORMATION

Check the malfunction on the vehicle that the customer describes.
Inspect the relation of the symptoms and the condition when the symptoms occur.

>> GO TO 4.

4.IDENTIFY THE MALFUNCTIONING SYSTEM WITH "SYMPTOM DIAGNOSIS"

Use "Symptom diagnosis" from the symptom inspection result in step 2 and then identify where to start performing the diagnosis based on possible causes and symptoms.

>> GO TO 5.

5.IDENTIFY THE MALFUNCTIONING PARTS WITH "DTC/CIRCUIT DIAGNOSIS"

Perform the diagnosis with "DTC/CIRCUIT DIAGNOSIS" of the applicable system.

>> GO TO 6.

6.REPAIR OR REPLACE THE MALFUNCTIONING PARTS

Repair or replace the specified malfunctioning parts.

>> GO TO 7.

7.FINAL CHECK

Check that malfunctions are not reproduced when obtaining the malfunction information from the customer, referring to the symptom inspection result in step 2.

Are the malfunctions corrected?

YES >> INSPECTION END

NO >> GO TO 4.

INSPECTION AND ADJUSTMENT

< BASIC INSPECTION >

INSPECTION AND ADJUSTMENT

ADDITIONAL SERVICE WHEN REMOVING BATTERY NEGATIVE TERMINAL

ADDITIONAL SERVICE WHEN REMOVING BATTERY NEGATIVE TERMINAL : Description

INFOID:000000008157940

Initial setting is necessary when battery terminal is removed, driver seat control unit or passenger seat control unit is replaced.

ADDITIONAL SERVICE WHEN REMOVING BATTERY NEGATIVE TERMINAL : Special Repair Requirement

INFOID:000000008157941

1.SYSTEM INITIALIZATION

Perform system initialization. Refer to [SE-9, "SYSTEM INITIALIZATION : Description"](#).

>> Work end.

ADDITIONAL SERVICE WHEN REPLACING CONTROL UNIT

ADDITIONAL SERVICE WHEN REPLACING CONTROL UNIT : Description

INFOID:000000008157942

Initial setting is necessary when battery terminal is removed, driver seat control unit or passenger seat control unit is replaced.

ADDITIONAL SERVICE WHEN REPLACING CONTROL UNIT : Special Repair Requirement

INFOID:000000008157943

1.SYSTEM INITIALIZATION

Perform system initialization. Refer to [SE-9, "SYSTEM INITIALIZATION : Description"](#).

>> Work end.

SYSTEM INITIALIZATION

SYSTEM INITIALIZATION : Description

INFOID:000000008157944

Always perform the initialization when the battery terminal is removed, driver seat control unit or passenger seat control unit is replaced. If the initialization is not performed, power walk-in function does not operation.

SYSTEM INITIALIZATION : Special Repair Requirement

INFOID:000000008157945

INITIALIZATION PROCEDURE

1. STEP-1

Slide the seat to the front edge.

NOTE:

If seat sliding position is already at the front edge, slide the seat backward once it to the front edge again.

>> Work end.

A
B
C
D
E
F
G
H
I
SE
K
L
M
N
O
P

POWER SEAT FOR DRIVER SIDE

< SYSTEM DESCRIPTION >

SYSTEM DESCRIPTION

POWER SEAT FOR DRIVER SIDE

POWER SEAT FUNCTION

POWER SEAT FUNCTION : System Diagram

INFOID:000000008157946

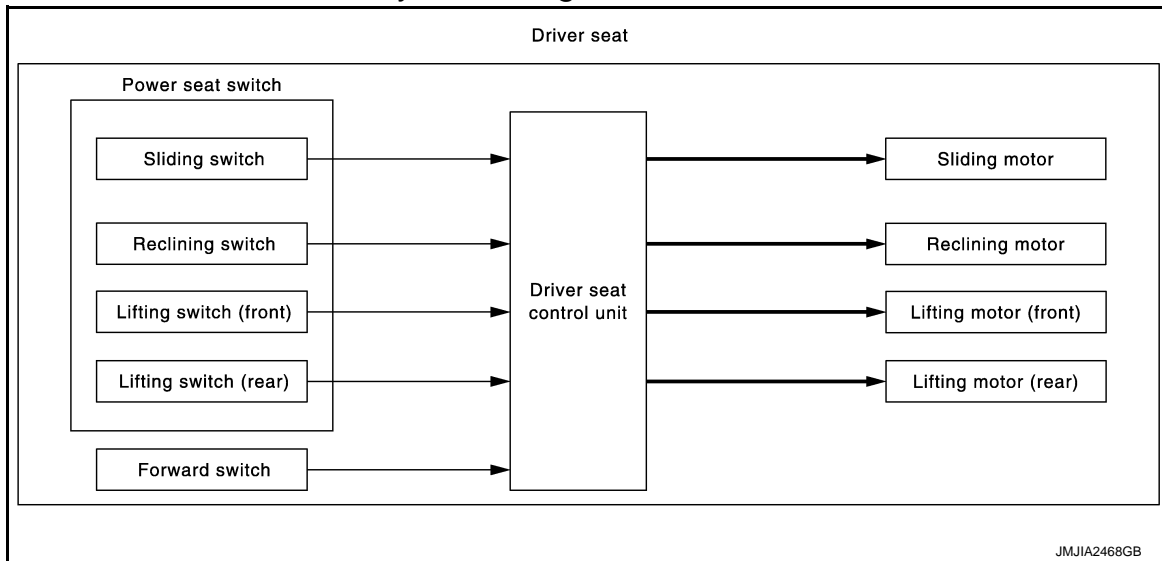

POWER SEAT FUNCTION : System Description

INFOID:000000008157947

- Power seat is operative regardless of the ignition switch position because power supply is always supplied to driver seat control unit.
- Driver seat control unit detects each power seat switch operation and applicable motor.

SLIDING OPERATION

When operating the sliding switch located in power seat switch, sliding motor operates and adjusts the front and back position of the seat.

RECLINING OPERATION

When operating the reclining switch located in power seat switch, reclining motor operates and adjusts the forward and backward position of the seatback. However, the reclining function does not operate when the forward switch is in the ON position.

LIFTING OPERATION

When operating the lifting switch located in power seat switch, lifting motor operates and adjusts the up and down position of the seat cushion (front and rear).

SLEEP MODE

- The driver seat control unit is equipped with the sleep mode to reduce the electric power consumption.
- The sleep mode is activated when all of the following conditions are satisfied.

1. Ignition switch OFF (steering LOCK position).
2. When no power seat motors are moving.
3. Power walk-in switch OFF.

WAKE-UP MODE

The sleep mode is cancelled when any status change is detected in the following items.

1. CAN communication.
2. Power seat switch.
3. Power walk-in switch.

POWER SEAT FOR DRIVER SIDE

< SYSTEM DESCRIPTION >

POWER SEAT FUNCTION : Component Parts Location

INFOID:000000008157948

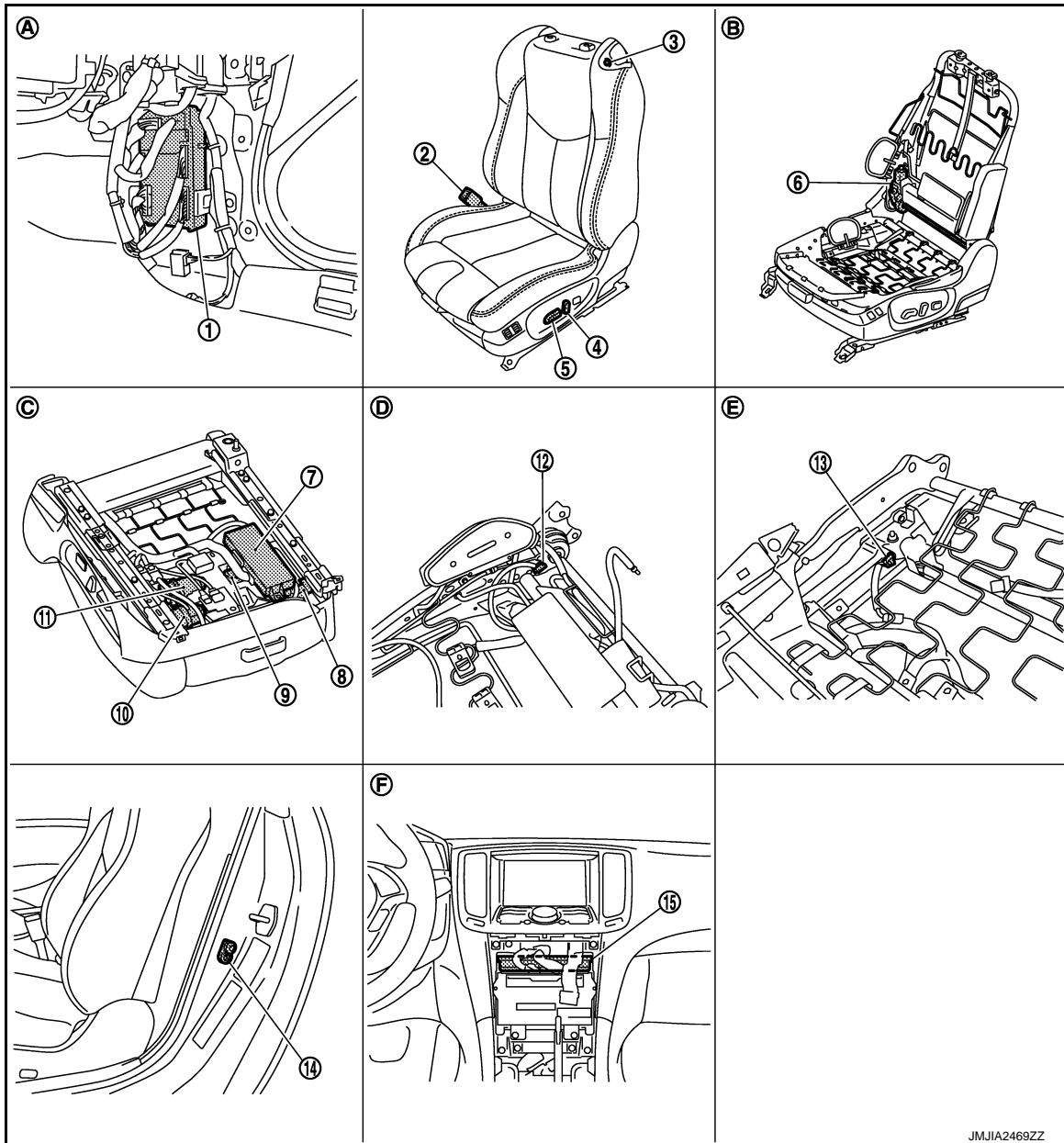

- | | | |
|---|---|--|
| 1. BCM | 2. Seat belt buckle switch (driver side) | 3. Power walk-in switch |
| 4. Reclining switch (power seat switch) | 5. Sliding, lifting switch (power seat switch) | 6. Reclining motor |
| 7. Driver seat control unit | 8. Sliding sensor | 9. Lifting motor (front) |
| 10. Sliding motor | 11. Lifting motor (rear) | 12. Forward switch |
| 13. Sliding limit switch | 14. Driver side door switch | 15. Unified meter and A/C amp. |
| A. Dash side lower (passenger side) | B. View with seat cushion pad and seat-back pad removed | C. View with back side of seat cushion |
| D. View with seatback pad removed | E. View with seat cushion pad removed | F. Behind cluster lid C |

A
B
C
D
E
F
G
H
I
SE
K
L
M
N
O
P

JMJIA2469ZZ

POWER SEAT FOR DRIVER SIDE

< SYSTEM DESCRIPTION >

POWER SEAT FUNCTION : Component Description

INFOID:000000008157949

Item	Function
Driver seat control unit	Operates the specific seat motor with the signal from the power seat switch
Power seat switch	Built-in reclining switch, sliding switch, and lifting switch
Reclining motor	Operates forward and backward movement of seatback with the power supplied to driver seat control unit.
Sliding motor	Operates forward and backward slide of seat with the power supplied to driver seat control unit.
Lifting motor (front/rear)	Operates up and down movement of seat cushion with the power supplied to driver seat control unit.
Forward switch	Detect folded down or folded up of the seatback.

POWER WALK-IN FUNCTION

POWER WALK-IN FUNCTION : System Diagram

INFOID:000000008157950

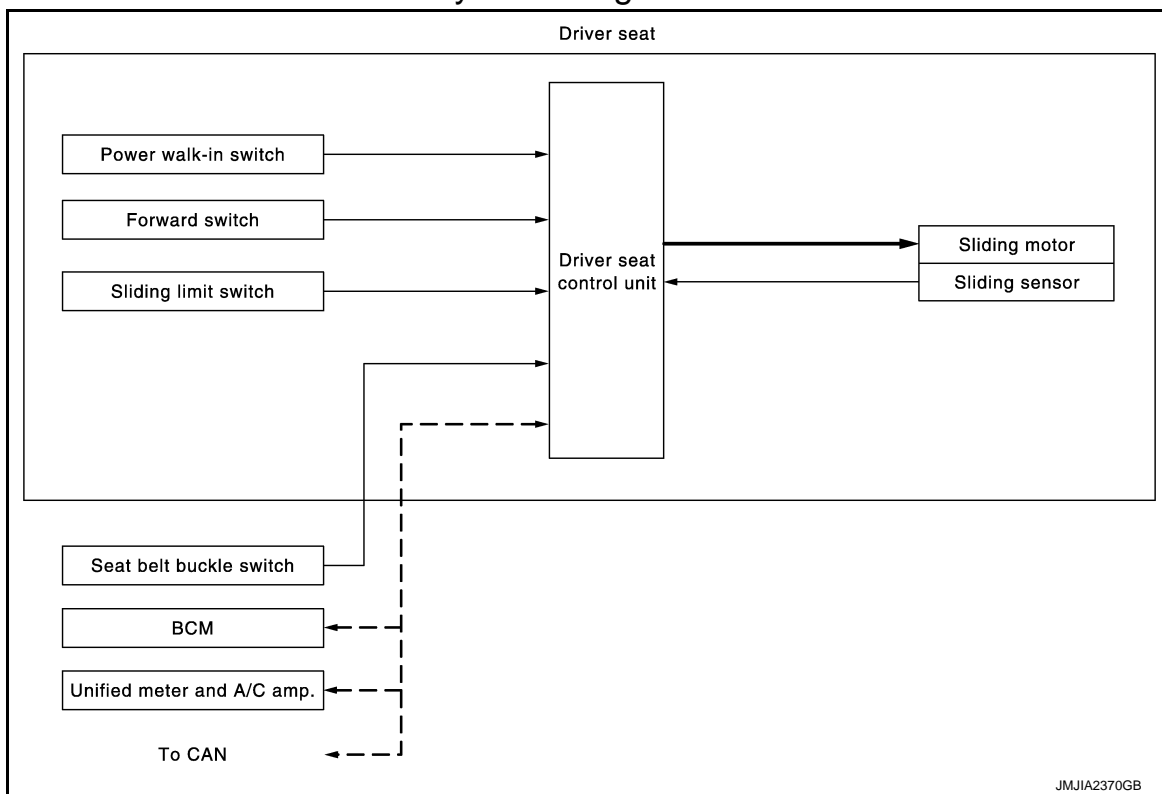

POWER WALK-IN FUNCTION : System Description

INFOID:000000008157951

OUTLINE

Automatically slides the driver seat by operating the power walk-in switch so as to easily allow entry to the rear seat.

Forward Operation

Slides the driver seat to the front end position (sliding limit switch: ON) by operating the power walk-in switch when the seatback is folded down.

The forward operation is stopped by folding up the seatback (forward switch: OFF) during the forward operation.

Backward Operation

The seatback is folded up after performing the forward operation of power walk-in function. Slide the driver seat to the backward position before performing the forward operation by operating the power walk-in switch.

If the sliding operation is performed after performing the forward operation, do not perform the backward operation.

POWER SEAT FOR DRIVER SIDE

< SYSTEM DESCRIPTION >

OPERATION PROCEDURE

Forward Operation

1. Open driver door.
2. Pull the walk-in lever on the upper part of seatback, and then the seatback is folded down.
3. Press the power walk-in switch.
4. Slide the seat to the front end position.

Backward Operation

1. Fold up the seatback after performing the forward operation.
2. Press the power walk-in switch.
3. Slide the seat to the previous position before the forward operation is performed.

OPERATION CONDITION

Perform the power walk-in function when the following conditions are satisfied.

Forward Operation

Item	Request status
Driver side door	Open
Driver side seat belt	Not fastened
Power seat switch (sliding)	Not operated
Vehicle speed	0 km/h
Seat position (sliding)	Other than front end
Seatback	Folded down

Backward Operation

Item	Request status
Initialize	Done
Driver side seat belt	Not fastened
Power seat switch (sliding)	Not operated
Vehicle speed	0 km/h
Seat position (sliding)	The seat sliding position does not move after performing the forward operation.
Seatback	Folded up

DETAIL FLOW

Forward Operation

Order	Inputs	Outputs	Control unit condition
1	Forward switch	—	Driver seat control unit detects that the seatback is folded down by the signal from the forward switch.
2	Power walk-in switch	—	The operation signal is input to the driver seat control unit when the power walk-in switch is operated.
3	—	Sliding motor (forward)	Driver seat control unit operates the seat sliding motor forward when it detects that the power walk-in switch is operated.
4	Sliding limit switch	—	Driver seat control unit stops the seat sliding motor when it detects that the seat sliding reaches the front end position by the sliding limit switch.

Backward Operation

POWER SEAT FOR DRIVER SIDE

< SYSTEM DESCRIPTION >

Order	Inputs	Outputs	Control unit condition
1	Forward switch	—	Driver seat control unit detects that the seatback is folded up by the signal from the forward switch.
2	Power walk-in switch	—	The operation signal is input to the driver seat control unit when the power walk-in switch is operated.
3	—	Sliding motor (backward)	Driver seat control unit operates the sliding motor backward when it detects that the power walk-in switch is operated.
4	Sliding sensor	—	Driver seat control unit stops the seat sliding motor when the seat sliding position reaches the front position before performing the forward operation by the signal from sliding sensor.

SLEEP MODE

- The driver seat control unit is equipped with the sleep mode to reduce the electric power consumption.
- The sleep mode is activated when all of the following conditions are satisfied.
 1. Ignition switch OFF (steering LOCK position).
 2. When no power seat motors are moving.
 3. Power walk-in switch OFF.

WAKE-UP MODE

The sleep mode is cancelled when any status change is detected in the following items.

1. CAN communication.
2. Power seat switch.
3. Power walk-in switch.

POWER SEAT FOR DRIVER SIDE

< SYSTEM DESCRIPTION >

POWER WALK-IN FUNCTION : Component Parts Location

INFOID:000000008157952

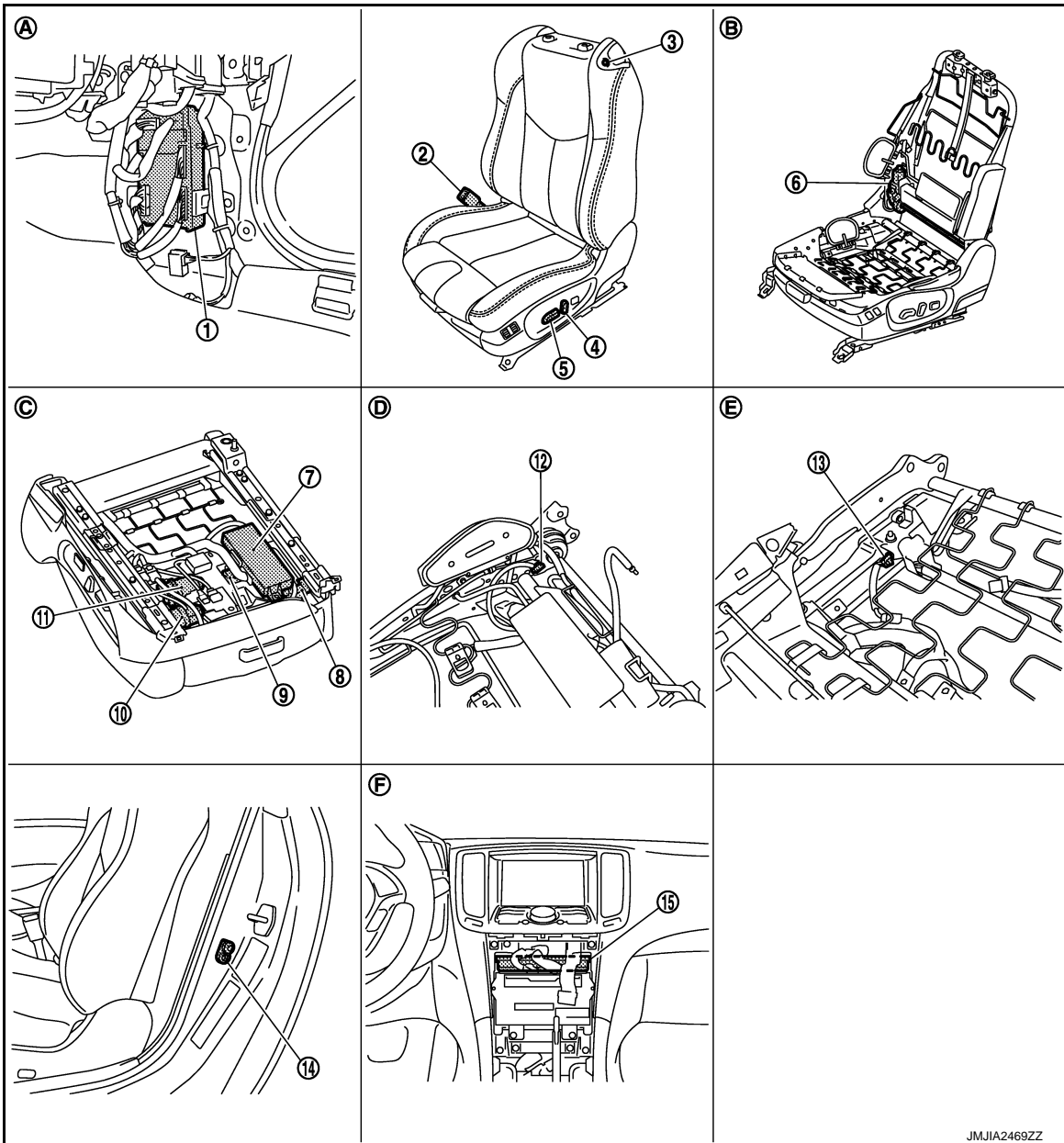

- | | | |
|---|--|--------------------------------|
| 1. BCM | 2. Seat belt buckle switch (driver side) | 3. Power walk-in switch |
| 4. Reclining switch (power seat switch) | 5. Sliding, lifting switch (power seat switch) | 6. Reclining motor |
| 7. Driver seat control unit | 8. Sliding sensor | 9. Lifting motor (front) |
| 10. Sliding motor | 11. Lifting motor (rear) | 12. Forward switch |
| 13. Sliding limit switch | 14. Driver side door switch | 15. Unified meter and A/C amp. |
- A. Dash side lower (passenger side) B. View with seat cushion pad and seat-back pad removed C. View with back side of seat cushion
- D. View with seatback pad removed E. View with seat cushion pad removed F. Behind cluster lid C

POWER WALK-IN FUNCTION : Component Description

INFOID:000000008157953

CONTROL UNITS

POWER SEAT FOR DRIVER SIDE

< SYSTEM DESCRIPTION >

Item	Function
Driver seat control unit	<ul style="list-style-type: none">• Main units of power walk-in function• It is connected to the CAN.
BCM	Transmits the following statuses to the driver seat control unit via CAN communication. <ul style="list-style-type: none">• Driver side door: OPEN/CLOSE• Starter: CRANKING/OTHER
Unified meter and A/C amp.	Transmits the vehicle speed signal to the driver seat control unit via CAN communication.

INPUT PARTS

Switches

Item	Function
Driver side door switch	Detects front door (driver side) open/close status.
Power walk-in switch	Performs the power walk-in operation by operating the power walk-in switch.
Sliding limit switch	Detects the front end position of seat sliding during the power walk-in function forward operation.
Seat belt buckle switch (driver side)	Detects the seat belt (driver side) fastening/releasing condition.
Forward switch	Detects the folded up/folded down condition of seatback that is the operation condition of power walk-in function.

Sensors

Item	Function
Sliding sensor	Detects the forward/backward position of seat.

OUTPUT PARTS

Item	Function
Sliding motor	Slides the seat forward/backward.

POWER SEAT FOR PASSENGER SIDE

< SYSTEM DESCRIPTION >

POWER SEAT FOR PASSENGER SIDE

POWER SEAT FUNCTION

POWER SEAT FUNCTION : System Diagram

INFOID:000000008157954

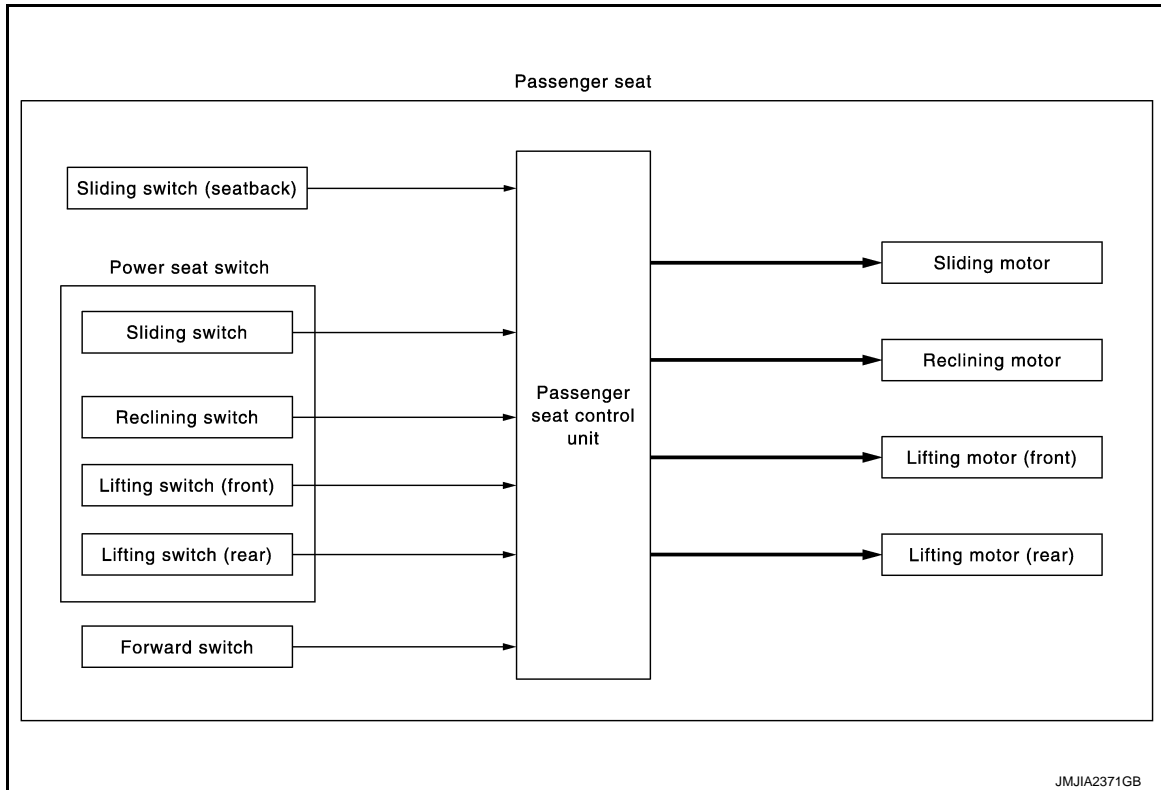

POWER SEAT FUNCTION : System Description

INFOID:000000008157955

- Power seat is operative regardless of the ignition switch position because power supply is always supplied to passenger seat control unit.
- Passenger seat control unit detects each power seat switch operation and applicable motor.

SLIDING OPERATION

When operating the sliding switch located in power seat switch and sliding switch (seatback), sliding motor operates and adjusts the front and back position of the seat.

RECLINING OPERATION

When operating the reclining switch located in power seat switch, reclining motor operates and adjusts the forward and backward position of the seatback. However, the reclining function does not operate when the forward switch is in the ON position.

LIFTING OPERATION

When operating the lifting switch located in power seat switch, lifting motor operates and adjusts the up and down position of the seat cushion (front and rear).

SLEEP MODE

- The passenger seat control unit is equipped with the sleep mode to reduce the electric power consumption.
- The sleep mode is activated when all of the following conditions are satisfied.

1. When no power seat motors are moving.
2. Power walk-in switch OFF.

WAKE-UP MODE

The sleep mode is cancelled when any status change is detected in the following items.

1. Power seat switch and sliding switch (seatback).
2. Power walk-in switch.

POWER SEAT FOR PASSENGER SIDE

< SYSTEM DESCRIPTION >

POWER SEAT FUNCTION : Component Parts Location

INFOID:000000008157956

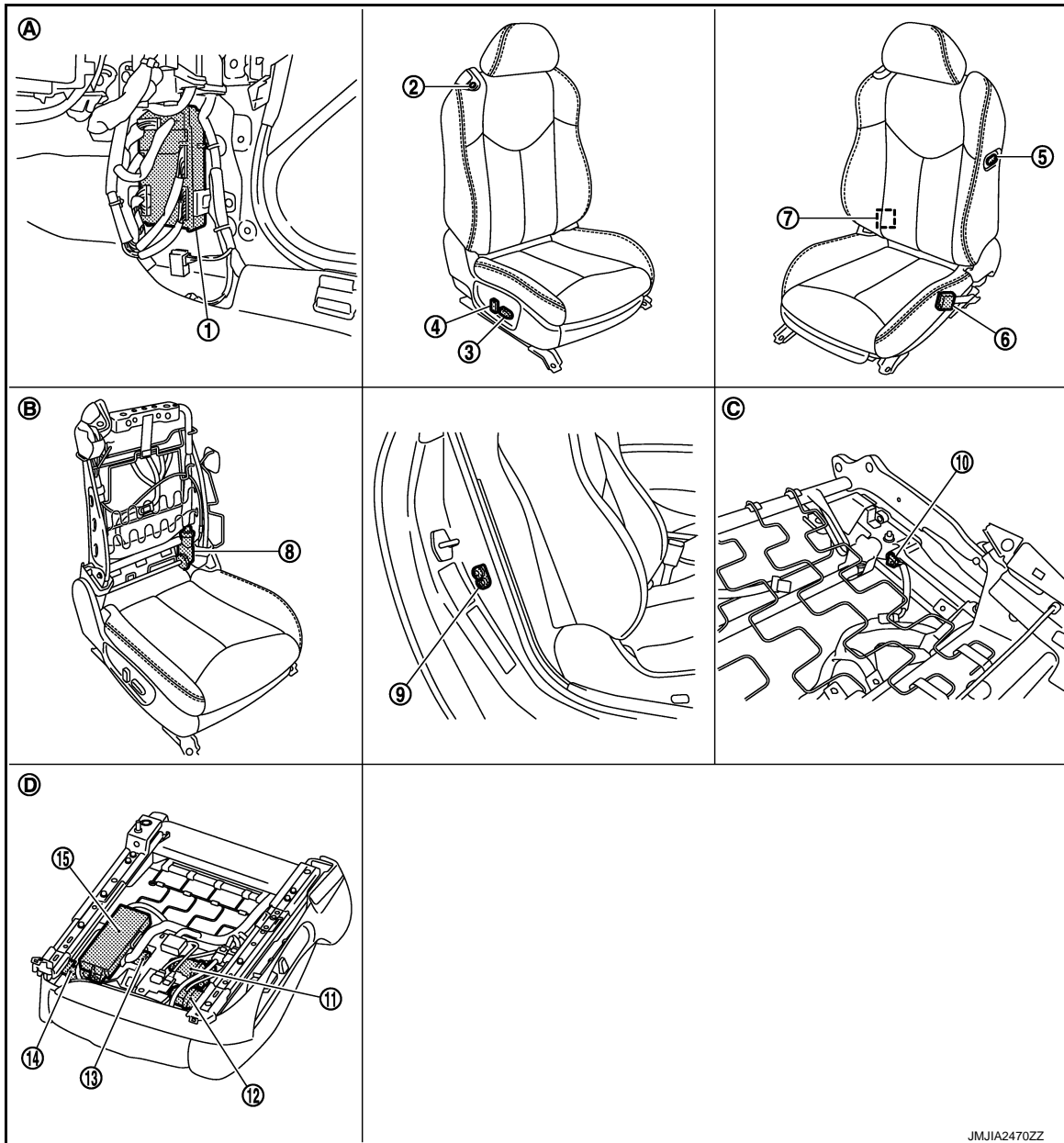

JMJIA2470ZZ

- | | | |
|---|-----------------------------------|--|
| 1. BCM | 2. Power walk-in switch | 3. Sliding, lifting switch (power seat switch) |
| 4. Reclining switch (power seat switch) | 5. Sliding switch (seatback) | 6. Seat belt buckle switch (passenger side) |
| 7. Forward switch | 8. Reclining motor | 9. Passenger side door switch |
| 10. Sliding limit switch | 11. Lifting motor (rear) | 12. Sliding motor |
| 13. Lifting motor (front) | 14. Sliding sensor | 15. Passenger seat control unit |
| A. Dash side lower (passenger side) | B. View with seatback pad removed | C. View with seatback pad removed |
| D. Back side of seat cushion | | |

POWER SEAT FOR PASSENGER SIDE

< SYSTEM DESCRIPTION >

POWER SEAT FUNCTION : Component Description

INFOID:000000008157957

Item	Function
BCM	The power received from battery to passenger seat control unit is supplied at all times.
Passenger seat control unit	Operates each motor with the signal from the power seat switch and sliding switch (seatback).
Power seat switch	Built-in reclining switch, sliding switch, and lifting switch, transmits operation signal to passenger seat control unit.
Sliding switch (seatback)	Transmits sliding operation signal to passenger seat control unit.
Reclining motor	Operates forward and backward movement of seatback with the power supplied to passenger seat control unit.
Sliding motor	Operates forward and backward slide of seat with the power supplied to passenger seat control unit.
Lifting motor (front/rear)	Operates up and down movement of seat cushion with the power supplied to passenger seat control unit.
Forward switch	Detect folded down or folded up of the seatback.

POWER WALK-IN FUNCTION

POWER WALK-IN FUNCTION : System Diagram

INFOID:000000008157958

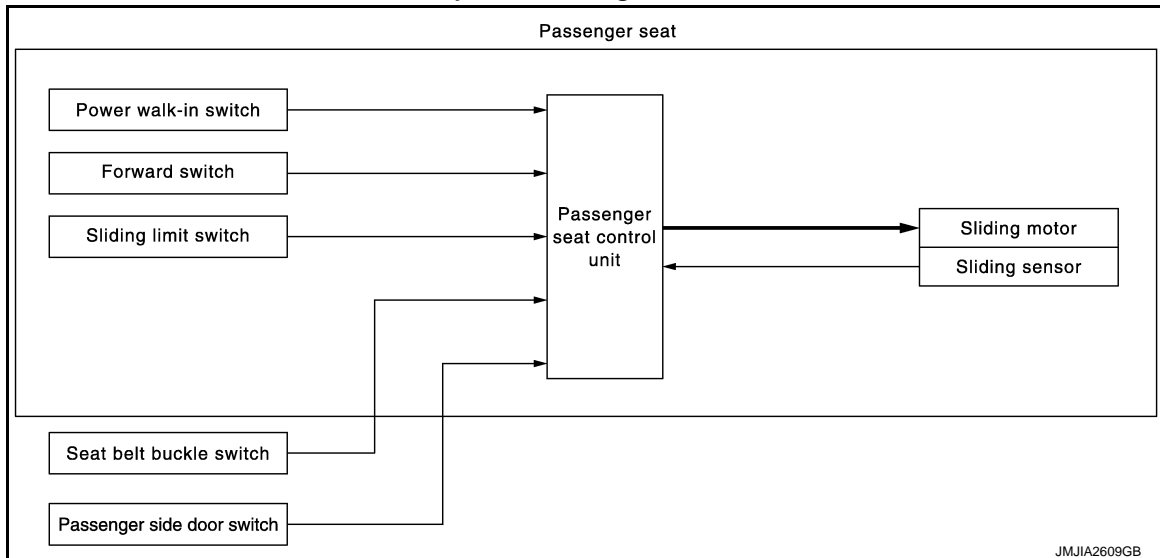

POWER WALK-IN FUNCTION : System Description

INFOID:000000008157959

OUTLINE

Automatically slides the passenger seat by operating the power walk-in switch so as to easily allow entry to the rear seat.

Forward Operation

Slides the driver seat to the front end position (sliding limit switch: ON) by operating the power walk-in switch when the seatback is folded down.

The forward operation is stopped by folding the seatback (forward switch: OFF) during the forward operation.

Backward Operation

The seatback is folded up after performing the forward operation of power walk-in function. Slide the driver seat to the backward position before performing the forward operation by operating the power walk-in switch. If the manual operation, memory operation, and Intelligent Key interlock operation are performed after performing the forward operation, do not perform the backward operation.

OPERATION PROCEDURE

Forward Operation

POWER SEAT FOR PASSENGER SIDE

< SYSTEM DESCRIPTION >

1. Open passenger door.
2. Pull the walk-in lever on the upper part of seatback, and then the seatback folds down.
3. Press the power walk-in switch.
4. Slide the seat to the front end position.

Backward Operation

1. Fold up the seatback after performing the forward operation.
2. Press the power walk-in switch.
3. Slide the seat to the previous position before the forward operation* is performed.

*: If the seat sliding position before starting the forward operation is more than 177.6 mm (6.992 in) from the front end position, the maximum is 177.6 mm (6.992 in).

OPERATION CONDITION

Perform the power walk-in function when the following conditions are satisfied.

Forward Operation

Item	Request status
Passenger side door	Open
Passenger side seat belt	Not fastened
Power seat switch (sliding)	Not operated
Seat position (sliding)	Other than front end
Seatback	Folded down

Backward Operation

Item	Request status
Initialize	Done
Passenger side seat belt	Not fastened
Power seat switch (sliding)	Not operated
Seat position (sliding)	The seat sliding position does not move after performing the forward operation.
Seatback	Folded up

DETAIL FLOW

Forward Operation

Order	Inputs	Outputs	Control unit condition
1	Forward switch	—	Passenger seat control unit detects that the seatback is folded down by the signal from the forward switch.
2	Power walk-in switch	—	The operation signal is input to the passenger seat control unit when the power walk-in switch is operated.
3	—	Sliding motor (forward)	Passenger seat control unit operates the seat sliding motor forward when it detects that the power walk-in switch is operated.
4	Sliding limit switch	—	Passenger seat control unit stops the seat sliding motor when it detects that the seat sliding reaches the front end position by the sliding limit switch.

Backward Operation

POWER SEAT FOR PASSENGER SIDE

< SYSTEM DESCRIPTION >

Order	Inputs	Outputs	Control unit condition
1	Forward switch	—	Passenger seat control unit detects that the seat-back is folded up by the signal from the forward switch.
2	Power walk-in switch	—	The operation signal is input to the passenger seat control unit when the power walk-in switch is operated.
3	—	Sliding motor (backward)	Passenger seat control unit operates the sliding motor backward when it detects that the power walk-in switch is operated.
4	Sliding sensor	—	Passenger seat control unit stops the seat sliding motor when the seat sliding position reaches the front position before performing the forward operation by the signal from sliding sensor or when the seat sliding position is 177.6 mm (6.992 in) from the front end position.

SLEEP MODE

- The passenger seat control unit is equipped with the sleep mode to reduce the electric power consumption.
- The sleep mode is activated when all of the following conditions are satisfied.
 1. When no power seat motors are moving.
 2. Power walk-in switch OFF.

WAKE-UP MODE

The sleep mode is cancelled when any status change is detected in the following items.

1. Power seat switch.
2. Power walk-in switch.

A
B
C
D
E
F
G
H
I
K
L
M
N
O
P

SE

POWER SEAT FOR PASSENGER SIDE

< SYSTEM DESCRIPTION >

POWER WALK-IN FUNCTION : Component Parts Location

INFOID:000000008157960

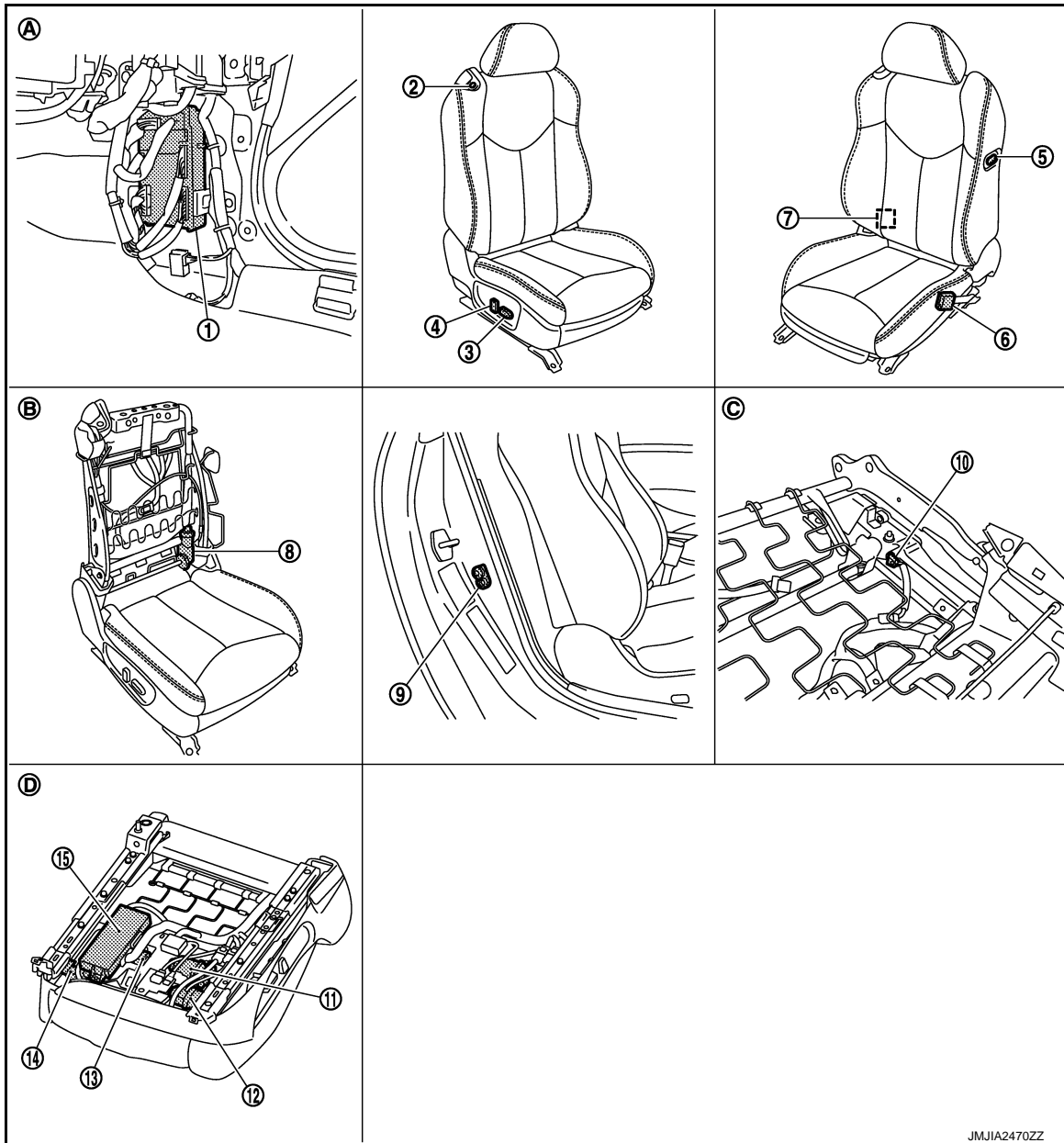

JMJIA2470ZZ

- | | | |
|---|-----------------------------------|--|
| 1. BCM | 2. Power walk-in switch | 3. Sliding, lifting switch (power seat switch) |
| 4. Reclining switch (power seat switch) | 5. Sliding switch (seatback) | 6. Seat belt buckle switch (passenger side) |
| 7. Forward switch | 8. Reclining motor | 9. Passenger side door switch |
| 10. Sliding limit switch | 11. Lifting motor (rear) | 12. Sliding motor |
| 13. Lifting motor (front) | 14. Sliding sensor | 15. Passenger seat control unit |
| A. Dash side lower (passenger side) | B. View with seatback pad removed | C. View with seatback pad removed |
| D. Back side of seat cushion | | |

POWER WALK-IN FUNCTION : Component Description

INFOID:000000008157961

CONTROL UNITS

POWER SEAT FOR PASSENGER SIDE

< SYSTEM DESCRIPTION >

Item	Function
Passenger seat control unit	Main unit of power walk-in function

A

INPUT PARTS

B

Switches

Item	Function
Passenger side door switch	Detects front door (passenger side) open/close status.
Power walk-in switch	Performs the power walk-in operation by operating the power walk-in switch.
Sliding limit switch	Detects the front end position of seat sliding during the power walk-in function forward operation.
Seat belt buckle switch (passenger side)	Detects the seat belt (passenger side) fastening/releasing condition.
Forward switch	Detects the folded up/folded down condition of seatback that is the operation condition of power walk-in function.

C

D

E

Sensors

F

Item	Function
Sliding sensor	Detects the forward/backward position of seat.

G

OUTPUT PARTS

Item	Function
Sliding motor	Slides the seat forward/backward.

H

I

SE

K

L

M

N

O

P

SIDE SUPPORT UNIT

< SYSTEM DESCRIPTION >

SIDE SUPPORT UNIT

System Description

INFOID:000000008157962

- While operating the side support switch, the pump located inside side support unit operates and adjust the air pressure in seat cushion and seatback side support.
- It is possible to soften the side support, by allowing some air to escape, by deflating the solenoid located inside side support.
- It is possible to adjust seat cushion and seatback differently while inflating or deflating solenoid located in side support unit.

Component Parts Location

INFOID:000000008157963

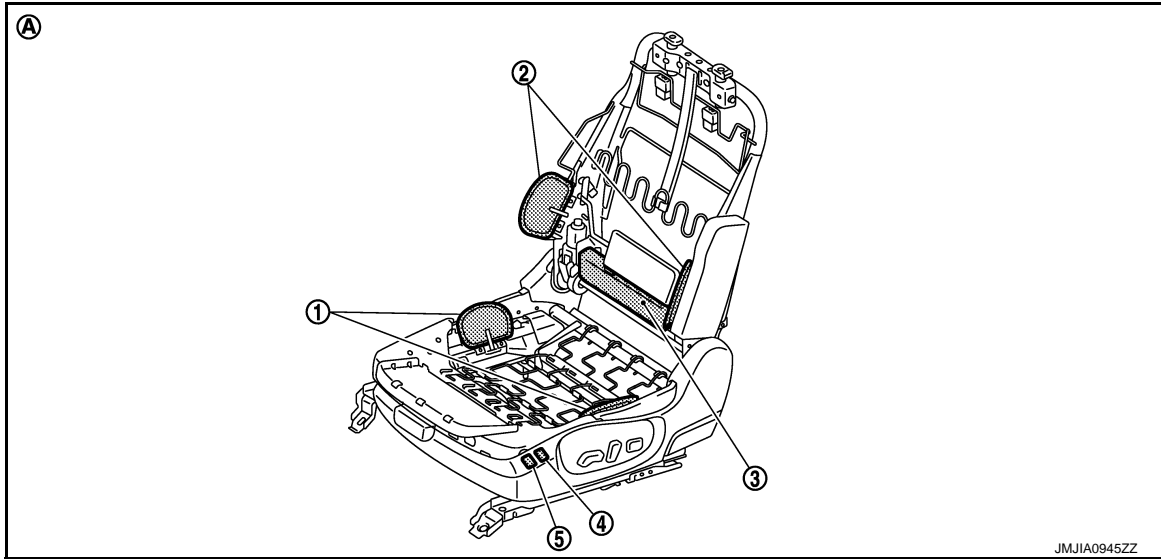

1. Side support (seat cushion)
 2. Side support (seatback)
 3. Side support unit
 4. Side support switch (seatback side)
 5. Side support switch (cushion side)
- A. View with seat cushion pad and seat back pad are removed.

Component Description

INFOID:000000008157964

Item	Function
Side support switch	With a built-in cushion side and seatback side, controls the power supplied to pump and to each solenoid.
Side support unit	Built-in pump, pump relay and solenoid, operates when pressing ON/OFF on side support switch.

HEATED SEAT

< SYSTEM DESCRIPTION >

HEATED SEAT

System Diagram

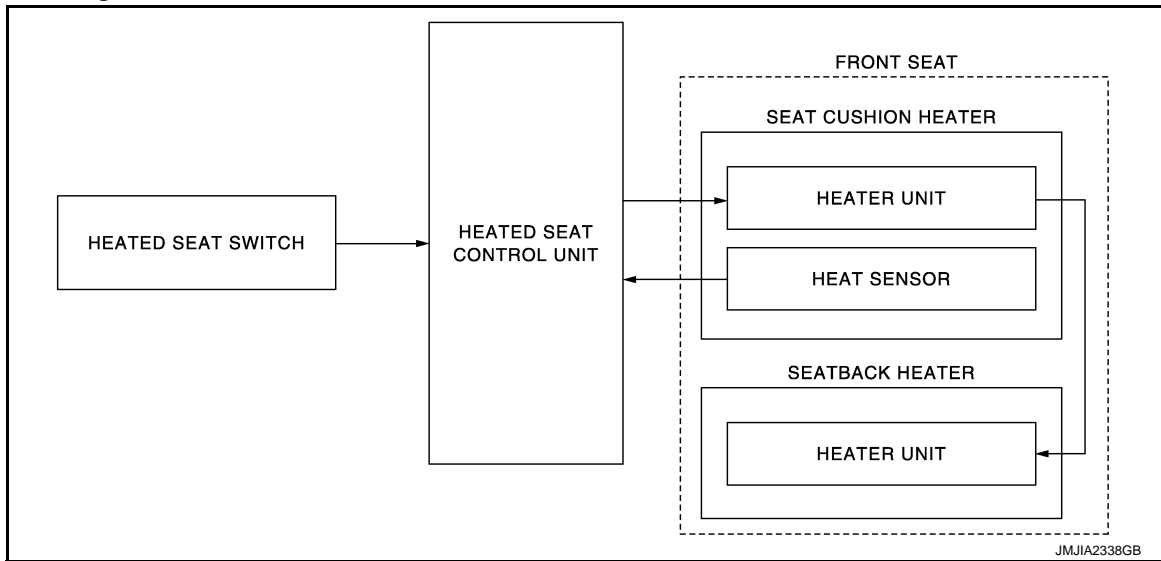

System Description

INFOID:000000008157966

- Heated seat is activated by heated seat switch while ignition switch is ON, and is equipped with the function to warm seat cushion and seatback.
- Heated seat is equipped with the 6-stage temperature adjustment function that adjusts temperature by operating heated seat switch to the optimal position.
- Heated seat is equipped with a thermostat in heater unit to prevent heater unit overheating.

OPERATION DESCRIPTION

- When operating heated seat switch to any position between 1 and 6 while ignition switch is ON, indicator illuminates, heated seat control unit supplies power supply to heater unit, and warms seat cushion and seatback.
- Heat sensor that is built in seat cushion heater detects seat cushion heater temperature and outputs to heated seat control unit.
- Heated seat control unit monitors the heated seat switch position and heater sensor temperature, and interrupts power supply to heater unit when the heat sensor temperature reaches.
- Heated seat control unit adjusts temperature preset temperature by supplying or interrupting power supply to heater unit.

A
B
C
D
E
F
G
H
I
SE
K
L
M
N
O
P

HEATED SEAT

< SYSTEM DESCRIPTION >

Component Parts Location

INFOID:000000008157967

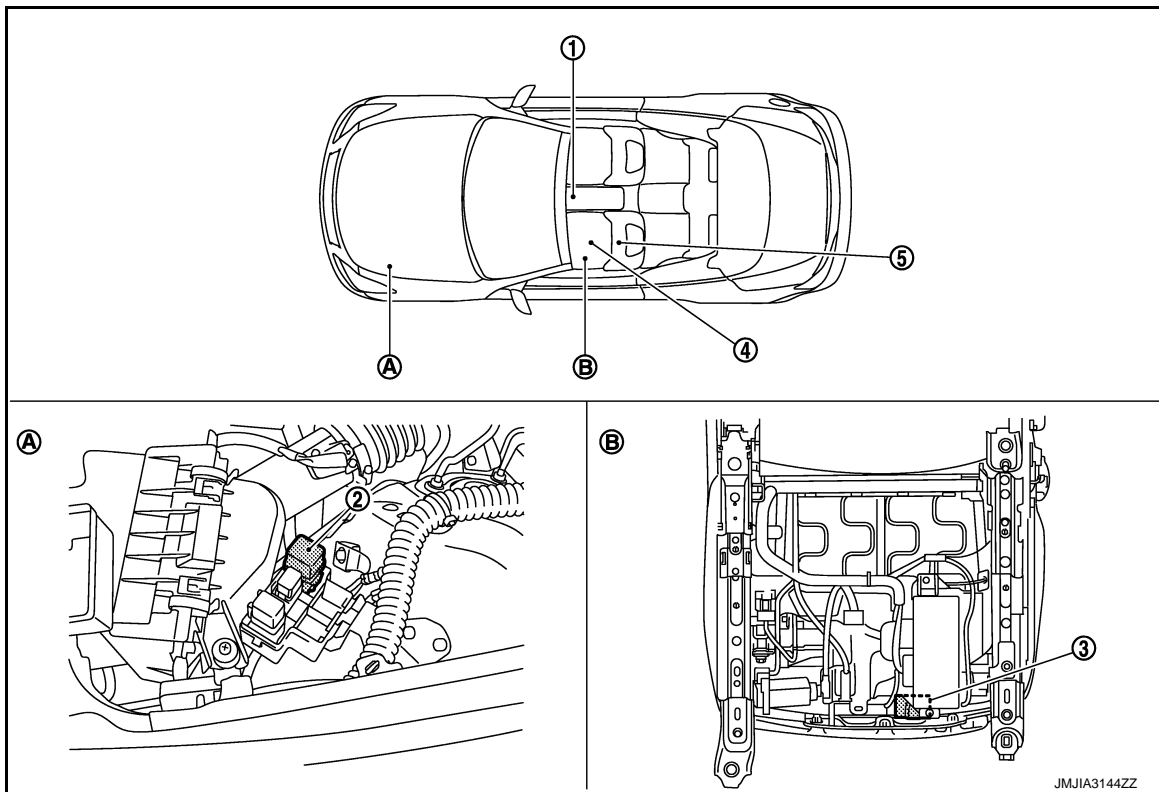

- | | | |
|---|---------------------------------------|-----------------------------|
| 1. Heated seat switch | 2. Heated seat relay | 3. Heated seat control unit |
| 4. Seat cushion heater | 5. Seatback heater | |
| A. Engine room fuse, fusesible link and relay box | B. Backside of seat cushion relay box | |

Component Description

INFOID:000000008157968

Item	Function
Heated seat switch	<ul style="list-style-type: none"> Adjusts heated seat temperature and deactivates heated seat Is equipped to indicator that indicates the operating condition
Seat cushion heater	<ul style="list-style-type: none"> Warms seat cushion Contains heater sensor that outputs seat cushion temperature to heated seat control unit
Seatback heater	Warms seatback
Heated seat control unit	Controls heated seat temperature and is independently placed in each seat cushion (driver seat and passenger seat)

LUMBAR SUPPORT

< SYSTEM DESCRIPTION >

LUMBAR SUPPORT

System Description

INFOID:000000008157969

- Lumbar support can operate regardless of the ignition switch position because battery power is supplied to it at all times.
- While operating the lumbar support switch, lumbar support motor operates which allows forward and backward operation of seatback support.

Component Parts Location

INFOID:000000008157970

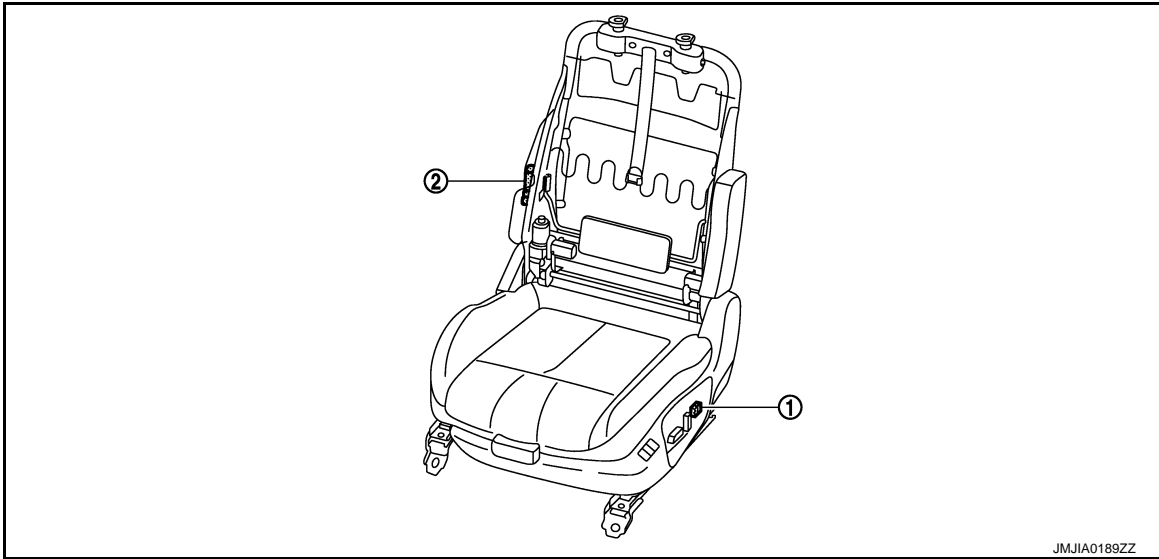

1. Lumbar support switch

2. Lumbar support motor

Component Description

INFOID:000000008157971

Item	Function
Lumbar support switch	Controls the power supplied to lumbar support motor.
Lumbar support motor	With the power supplied to lumbar support switch, operates the forward and backward movement of seatback support device.

A
B
C
D
E
F
G
H
I
SE
K
L
M
N
O
P

CLIMATE CONTROLLED SEAT

< SYSTEM DESCRIPTION >

CLIMATE CONTROLLED SEAT

System Diagram

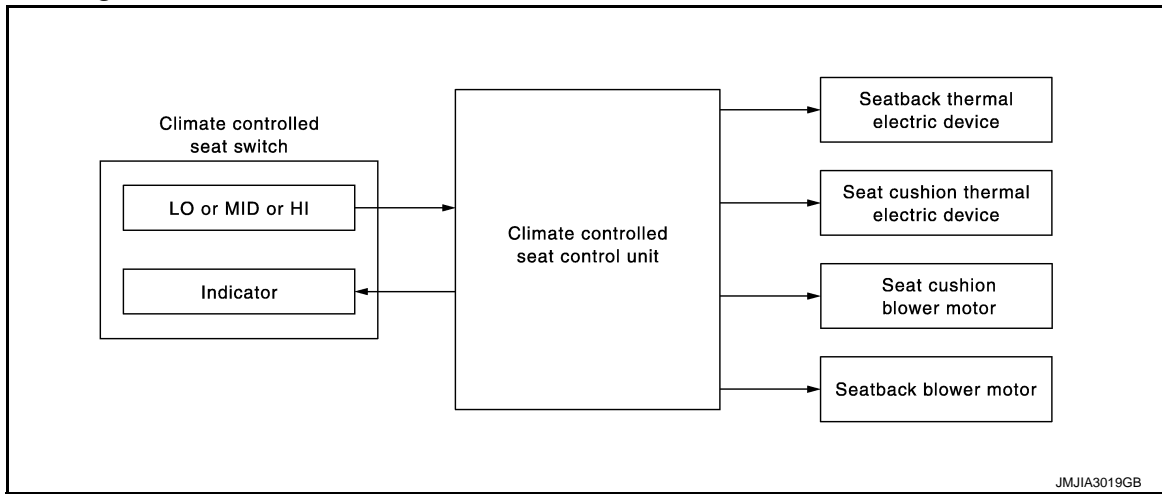

System Description

INFOID:000000008157973

- The climate controlled seat system is controlled by the climate controlled seat control unit.
- Operation of the climate controlled switch sends heated or cooled airflow and adjusts the seat temperature.

SEAT CUSHION AND SEATBACK TEMPERATURE ADJUSTMENT FUNCTION

- One thermal electric device (TED) unit is installed in each seat cushion and seatback. The device heats or cools, sends airflow to the seat surface, and adjusts the seat temperature.
- The thermal electric device (TED) is a heat exchanger that has a function to heat or cool the airflow from the seat cushion blower motor and seatback blower motor. (By changing the direction of the current from the power supply, the device takes or gives heat, and adjustsexchange process depending on voltage.

CAUTION:

- **The thermal electric device has a dual-climate function that allows one side to operate at a high temperature and the other to operate at a low temperature simultaneously.**
- **Before starting always turn OFF the switch and check that the electric device is cold.**

FAIL-SAFE

The fail-safe function is adopted for the climate controlled seat control to [SE-162, "Fail-safe"](#).

CLIMATE CONTROLLED SEAT

< SYSTEM DESCRIPTION >

Component Parts Location

INFOID:000000008157974

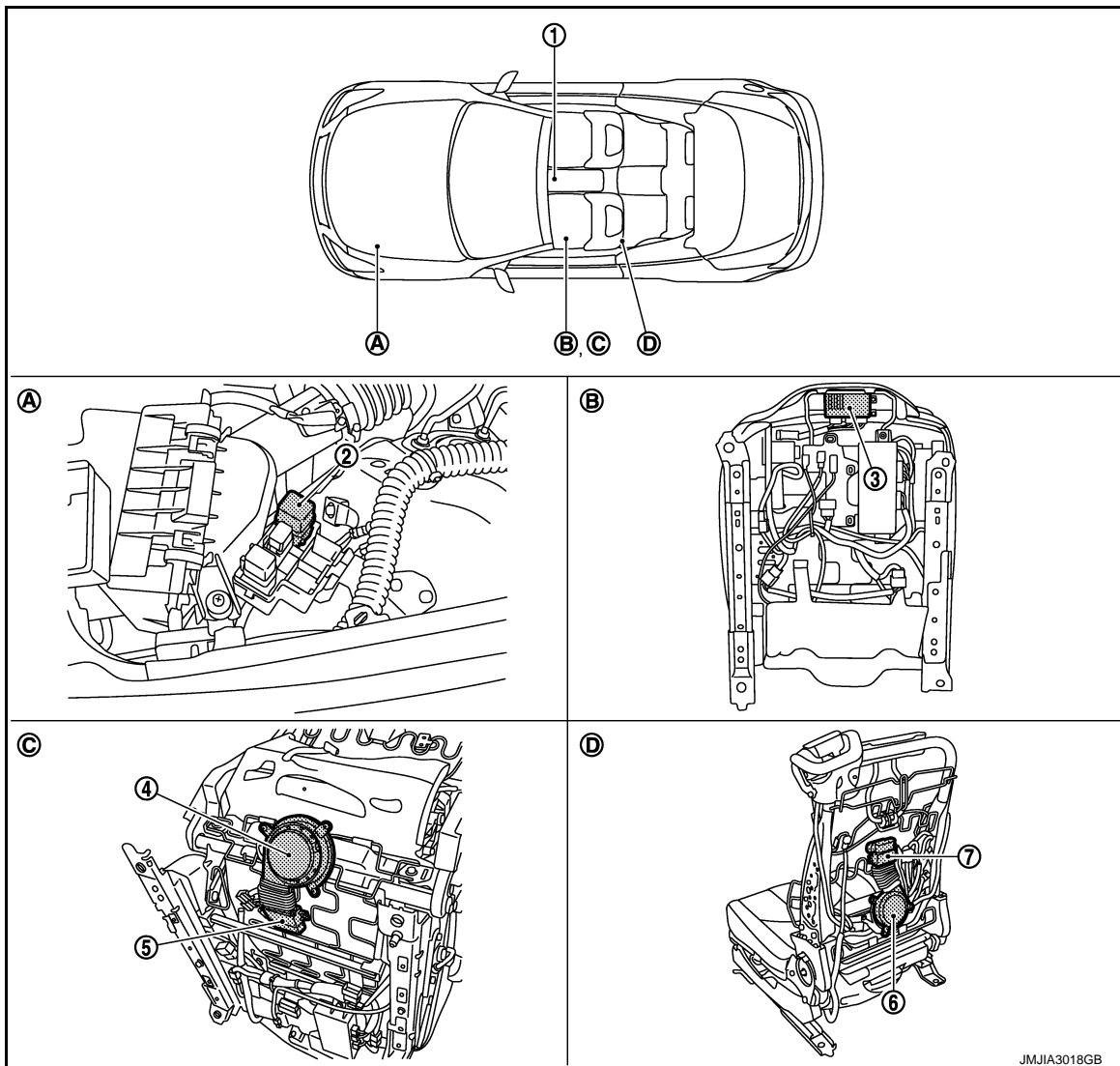

- | | | |
|---|---|---|
| 1. Climate controlled seat switch | 2. Climate controlled seat relay | 3. Climate controlled seat control unit (driver side) |
| 4. Climate controlled seat cushion blower motor (driver side) | 5. Seat cushion thermal electric device (driver side) | 6. Climate controlled seatback blower motor (driver side) |
| 7. Seatback thermal electric device (driver side) | | |
| A. Engine room fuse, fusesible link and relay box | B. Back side of seat cushion. | C. View with seat cushion rear finisher. |
| D. View with seatback board. | | |

Component Description

INFOID:000000008157975

Item	Function
Climate controlled seat relay	Supplies power to the climate controlled seat control unit in accordance with the key switch position that is ON or OFF
Climate controlled seat control unit	Installed in the seat cushion backside and controls the climate controlled seat cushion and-back blower motor, seatback thermal electric device, and seat cushion thermal electric device in accordance with the input signal

A
B
C
D
E
F
G
H
I
SE
K
L
M
N
O
P

CLIMATE CONTROLLED SEAT

< SYSTEM DESCRIPTION >

Item	Function
Climate controlled seat switch	Installed in the center console and transmits signals to climate controlled seat control unit in accordance with the HEAT (heated airflow) or COOL (cooled airflow) switch operation and the temperature switch operation
Seatback blower motor	Installed in the seatback and sends the airflow to the seatback thermal electric device in accordance with the control from the climate controlled seat control unit
Seat cushion blower motor	Installed in the seat cushion backside and sends the airflow to the seat cushion thermal electric device in accordance with the control from the climate controlled seat control unit
Seatback thermal electric device	Installed in the seatback backside and heats or cools the airflow from the climate controlled seat blower motor in accordance with the control from the climate controlled seat control unit
Seat cushion thermal electric device	Installed in the seat cushion backside and heats or cools the airflow from the climate controlled seat blower motor in accordance with the control from the climate controlled seat control unit

DIAGNOSIS SYSTEM (DRIVER SEAT C/U)

< SYSTEM DESCRIPTION >

DIAGNOSIS SYSTEM (DRIVER SEAT C/U)

CONSULT Function

INFOID:000000008801775

The automatic drive positioner system can be checked and diagnosed for component operation using CONSULT.

APPLICATION ITEMS

Diagnostic mode	Description
SELF-DIAG RESULTS	Performs self-diagnosis for the auto drive positioner system and displays the results.
DATA MONITOR	Displays input signals transmitted from various switches and sensors to driver seat control unit in real time.
CAN DIAG SUPPORT MNTR	The result of transmit/receive diagnosis of CAN communication can be read.
ACTIVE TEST	Drives each output device.
ECU PART NUMBER	Displays part numbers of driver seat control unit.

SELF DIAGNOSTIC RESULTS

Refer to [ADP-146, "DTC Index"](#).

DATA MONITOR

NOTE:

The following table includes information (items) inapplicable to this vehicle. For information (items) applicable to this vehicle, refer to CONSULT display items.

Monitor Item	Unit	Main Signals	Selection From Menu	Contents
SET SW	"ON/OFF"	×	×	ON/OFF status judged from the setting switch signal.
MEMORY SW 1	"ON/OFF"	×	×	ON/OFF status judged from the seat memory switch 1 signal.
MEMORY SW 2	"ON/OFF"	×	×	ON/OFF status judged from the seat memory switch 2 signal.
SLIDE SW-FR*3	"ON/OFF"	×	×	ON/OFF status judged from the sliding switch (forward) signal.
SLIDE SW-RR*3	"ON/OFF"	×	×	ON/OFF status judged from the sliding switch (backward) signal.
RECLN SW-FR*3	"ON/OFF"	×	×	ON/OFF status judged from the reclining switch (forward) signal.
RECLN SW-RR*3	"ON/OFF"	×	×	ON/OFF status judged from the reclining switch (backward) signal.
LIFT FR SW-UP*3	"ON/OFF"	×	×	ON/OFF status judged from the lifting switch front (upward) signal.
LIFT FR SW-DN*3	"ON/OFF"	×	×	ON/OFF status judged from the lifting switch front (downward) signal.
LIFT RR SW-UP*3	"ON/OFF"	×	×	ON/OFF status judged from the lifting switch rear (upward) signal.
LIFT RR SW-DN*3	"ON/OFF"	×	×	ON/OFF status judged from the lifting switch rear (downward) signal.
MIR CON SW-UP	"ON/OFF"	×	×	ON/OFF status judged from the mirror switch (upward) signal.
MIR CON SW-DN	"ON/OFF"	×	×	ON/OFF status judged from the mirror switch (downward) signal.
MIR CON SW-RH	"ON/OFF"	×	×	ON/OFF status judged from the door mirror remote control switch (passenger side) signal.
MIR CON SW-LH	"ON/OFF"	×	×	ON/OFF status judged from the door mirror remote control switch (driver side) signal.
MIR CHNG SW-R	"ON/OFF"	×	×	ON/OFF status judged from the door mirror remote control switch (switching to right) signal.
MIR CHNG SW-L	"ON/OFF"	×	×	ON/OFF status judged from the door mirror remote control switch (switching to left) signal.

DIAGNOSIS SYSTEM (DRIVER SEAT C/U)

< SYSTEM DESCRIPTION >

Monitor Item	Unit	Main Signals	Selection From Menu	Contents
TILT SW-UP	"ON/OFF"	×	×	ON/OFF status judged from the tilt switch (upward) signal.
TILT SW-DOWN	"ON/OFF"	×	×	ON/OFF status judged from the tilt switch (downward) signal.
TELESCO SW-FR	"ON/OFF"	×	×	ON/OFF status judged from the telescoping switch (forward) signal.
TELESCO SW-RR	"ON/OFF"	×	×	ON/OFF status judged from the telescoping switch (backward) signal.
FORWARD SW*3	"ON/OFF"	×	×	ON/OFF status judged from the forward switch signal.
WALK-IN SW*3	"ON/OFF"	×	×	ON/OFF status judged from the power walk-in switch signal.
FWD LIMIT SW*3	"ON/OFF"	×	×	ON/OFF status judged from the sliding limit switch signal.
SEAT BELT SW*3	"ON/OFF"	×	×	ON/OFF status judged from the seat belt buckle switch signal.
DETENT SW*1	"ON/OFF"	×	×	The selector lever position "OFF (P position) / ON (other than the P position)" judged from the detention switch signal.
PARK BRAKE SW*2	"ON/OFF"	×	×	The parking brake condition "ON (applied) / OFF (release)" judged from the parking brake switch signal.
STARTER SW	"ON/OFF"	×	×	Ignition key switch ON (START, ON) /OFF (ACC, OFF) status judged from the ignition switch signal.
SLIDE PULSE*3	—	—	×	Value (32768) when battery connections are standard. If it moves backward, the value increases. If it moves forward, the value decreases.
RECLN PULS*4	—	—	×	Value (32768) when battery connections are standard. If it moves backward, the value increases. If it moves forward, the value decreases.
LIFT FR PULSE*4	—	—	×	Value (32768) when battery connections are standard. If it moves DOWN, the value increases. If it moves UP, the value decreases.
LIFT RR PULSE*4	—	—	×	Value (32768) when battery connections are standard. If it moves DOWN, the value increases. If it moves UP, the value decreases.
MIR/SEN RH U-D	"V"	—	×	Voltage input from door mirror sensor (passenger side) upward/downward is displayed.
MIR/SEN RH R-L	"V"	—	×	Voltage input from door mirror sensor (passenger side) leftward/rightward is displayed.
MIR/SEN LH U-D	"V"	—	×	Voltage input from door mirror sensor (driver side) upward/downward is displayed.
MIR/SEN LH R-L	"V"	—	×	Voltage input from door mirror sensor (driver side) leftward/rightward is displayed.
TILT SEN	"V"	—	×	Voltage input from tilt sensor upward/downward is displayed.
TELESCO SEN	"V"	—	×	Voltage input from telescopic sensor forward/backward is displayed.

*1: M/T models display all item except this item.

*2: A/T models display all item except this item.

*3: Only this item is displayed for driver seat without automatic drive positioner system.

*4: It is displayed but is not operated for models with driver seat without automatic driver positioner system.

ACTIVE TEST

CAUTION:

When driving vehicle, never perform active test.

Test item	Description
SEAT SLIDE	Activates/deactivates the sliding motor.
SEAT RECLINING	Activates/deactivates the reclining motor.

DIAGNOSIS SYSTEM (DRIVER SEAT C/U)

< SYSTEM DESCRIPTION >

Test item	Description
SEAT LIFTER FR	Activates/deactivates the lifting motor (front).
SEAT LIFTER RR	Activates/deactivates the lifting motor (rear).
TILT MOTOR*	Activates/deactivates the tilt motor.
TELESCO MOTOR*	Activates/deactivates the telescopic motor.
MIRROR MOTOR RH*	Activates/deactivates the mirror motor (passenger side).
MIRROR MOTOR LH*	Activates/deactivates the mirror motor (driver side).
MEMORY SW INDCTR*	Turns ON/OFF the memory indicator.

*: Does not display without automatic driver position system.

A
B
C
D
E
F
G
H
I
K
L
M
N
O
P

SE

U1000 CAN COMM CIRCUIT

< DTC/CIRCUIT DIAGNOSIS >

DTC/CIRCUIT DIAGNOSIS

U1000 CAN COMM CIRCUIT

Description

INFOID:000000008157977

CAN (Controller Area Network) is a serial communication line for real time applications. It is an on-vehicle multiplex communication line with high data communication speed and excellent error detection ability. Modern vehicle is equipped with many electronic control unit, and each control unit shares information and links with other control units during operation (not independent). In CAN communication, control units are connected with 2 communication lines (CAN-H, CAN-L) allowing a high rate of information transmission with less wiring. Each control unit transmits/receives data but selectively reads required data only.

DTC Logic

INFOID:000000008157978

DTC DETECTION LOGIC

DTC	Trouble diagnosis name	DTC detecting condition	Possible cause
U1000	CAN COMM CIRCUIT	<ul style="list-style-type: none">Driver seat control unit cannot communicate to other control units.Driver seat control unit cannot communicate for more than the specified time.	Harness or connectors (CAN communication line is open or shorted)

DTC CONFIRMATION PROCEDURE

1.STEP 1

Turn ignition switch ON and wait for 3 seconds or more.

>> GO TO 2.

2.STEP 2

Check "Self Diagnostic Result" using CONSULT.

Is the DTC detected?

YES >> Perform diagnosis procedure. Refer to [SE-34, "Diagnosis Procedure"](#).
NO >> INSPECTION END

Diagnosis Procedure

INFOID:000000008157979

Refer to [LAN-14, "Trouble Diagnosis Flow Chart"](#).

Special Repair Requirement

INFOID:000000008157980

Refer to [SE-9, "ADDITIONAL SERVICE WHEN REPLACING CONTROL UNIT : Special Repair Requirement"](#).

B2112 SLIDING MOTOR

< DTC/CIRCUIT DIAGNOSIS >

B2112 SLIDING MOTOR

Description

INFOID:000000008157981

- The sliding motor is installed to the seat cushion frame.
- The sliding motor is activated via the driver seat control unit.
- Slides the seat forward/rearward by changing the rotation direction of sliding motor.

DTC Logic

INFOID:000000008157982

DTC DETECTION LOGIC

DTC No.	Trouble diagnosis name	DTC detecting condition	Possible cause
B2112	SEAT SLIDE	The driver seat control unit detects the output of sliding motor output terminal for 0.1 seconds or more even if the sliding switch is not input	<ul style="list-style-type: none">• Driver seat control unit• Slide motor harness is shorted

DTC CONFIRMATION PROCEDURE

1.STEP 1

1. Turn ignition switch ON.
2. Check "Self diagnostic result" using CONSULT.

Is the DTC detected?

- YES >> Refer to [SE-35, "Diagnosis Procedure"](#).
NO >> INSPECTION END

Diagnosis Procedure

INFOID:000000008157983

1.PERFORM DTC CONFIRMATION PROCEDURE

1. Turn ignition switch ON.
2. Check "Self diagnostic result" using CONSULT.
3. Erase the DTC.
4. Perform DTC confirmation procedure. Refer to [SE-35, "DTC Logic"](#).

Is the DTC displayed again?

- YES >> GO TO 2.
NO >> GO TO 4.

2.CHECK SLIDING MOTOR CIRCUIT (POWER SHORT)

1. Turn ignition switch OFF.
2. Disconnect sliding motor connector and driver seat control unit connector.
3. Check voltage between sliding motor harness connector and ground.

(+)		(-)	Voltage (V) (Approx.)
Sliding motor			
Connector	Terminal		
B525	35	Ground	0
	42		

Is the inspection result normal?

- YES >> GO TO 3.
NO >> Repair or replace harness.

3.CHECK DRIVER SEAT CONTROL UNIT OUTPUT SIGNAL

1. Connect driver seat control unit connector.
2. Check voltage between driver seat control unit harness connector and ground.

B2112 SLIDING MOTOR

< DTC/CIRCUIT DIAGNOSIS >

(+)		(-)	Voltage (V) (Approx.)
Driver seat control unit			
Connector	Terminal	Ground	0
B504	35		
	42		

Is the inspection result normal?

YES >> GO TO 4.

NO >> Replace driver seat control unit. Refer to [SE-224, "Removal and Installation"](#)

4. CHECK INTERMITTENT INCIDENT

Check intermittent incident.

Refer to [GI-42, "Intermittent Incident"](#).

>> INSPECTION END

B2113 RECLINING MOTOR

< DTC/CIRCUIT DIAGNOSIS >

B2113 RECLINING MOTOR

Description

INFOID:000000008157984

- The seat reclining motor is installed to the seatback frame.
- The seat reclining motor is activated with the driver seat control unit.
- Tilts the seatback frontward/rearward by changing the rotation direction of reclining motor.

DTC Logic

INFOID:000000008157985

DTC DETECTION LOGIC

DTC No.	Trouble diagnosis name	DTC detecting condition	Possible cause
B2113	SEAT RECLINING	The driver seat control unit detects the output of reclining motor output terminal for 0.1 seconds or more even if the reclining switch is not input.	<ul style="list-style-type: none"> • Driver seat control unit • Reclining motor harness is power shorted

DTC CONFIRMATION PROCEDURE

1. PERFORM DTC CONFIRMATION PROCEDURE

1. Turn ignition switch ON.
2. Check "Self diagnostic result" using CONSULT.

Is the DTC detected?

- YES >> Refer to [SE-37, "Diagnosis Procedure"](#).
 NO >> INSPECTION END

Diagnosis Procedure

INFOID:000000008157986

1. PERFORM DTC CONFIRMATION PROCEDURE

1. Turn ignition switch ON.
2. Check "Self diagnostic result" using CONSULT.
3. Erase the DTC.
4. Perform DTC confirmation procedure. Refer to [SE-37, "DTC Logic"](#).

Is the DTC displayed again?

- YES >> GO TO 2.
 NO >> Check intermittent incident. Refer to [GI-42, "Intermittent Incident"](#).

2. CHECK RECLINING MOTOR CIRCUIT (POWER SHORT)

1. Turn ignition switch OFF.
2. Disconnect reclining motor and driver seat control unit connector.
3. Check voltage between reclining motor harness connector and ground.

(+)		(-)	Voltage (V) (Approx.)
Reclining motor			
Connector	Terminal		
B524	36	Ground	0
	44		

Is the inspection result normal?

- YES >> GO TO 3.
 NO >> Repair or replace harness.

3. CHECK DRIVER SEAT CONTROL UNIT OUTPUT SIGNAL

1. Connect driver seat control unit connector.
2. Check voltage between driver seat control unit harness connector and ground.

B2113 RECLINING MOTOR

< DTC/CIRCUIT DIAGNOSIS >

(+)		(-)	Voltage (V) (Approx.)
Driver seat control unit			
Connector	Terminal		
B504	36	Ground	0
	44		

Is the inspection result normal?

YES >> GO TO 4.

NO >> Replace driver seat control unit. Refer to [SE-224, "Removal and Installation"](#).

4. CHECK INTERMITTENT INCIDENT

Refer to [GI-42, "Intermittent Incident"](#).

>> INSPECTION END

POWER SUPPLY AND GROUND CIRCUIT

< DTC/CIRCUIT DIAGNOSIS >

POWER SUPPLY AND GROUND CIRCUIT

DRIVER SEAT CONTROL UNIT

DRIVER SEAT CONTROL UNIT : Diagnosis Procedure

INFOID:000000008157987

NOTE:

Do not disconnect the battery negative terminal and the driver seat control unit connector until DTC is confirmed using CONSULT.

1.CHECK FUSE AND FUSIBLE LINK

Check that the following fuse and fusible link are not fusing.

Terminal No.	Signal name	Fuse and fusible link No.
33	Battery power supply	K (40 A)
40		10 (10 A)

Is the inspection result normal?

YES >> GO TO 2.

NO >> Replace the blown fuse and fusible link after repairing the affected circuit if fuse and fusible link are blown.

2.CHECK POWER SUPPLY CIRCUIT

1. Turn ignition switch OFF.
2. Disconnect driver seat control unit connector.
3. Check voltage between driver seat control unit harness connector and ground.

(+)		(-)	Voltage (V) (Approx.)
Driver seat control unit			
Connector	Terminal	Ground	Battery voltage
B504	33		
	40		

Is the inspection result normal?

YES >> GO TO 3.

NO-1 >> Repair or replace harness.

NO-2 >> Check circuit breaker, and replace if NG.

3.CHECK GROUND CIRCUIT

Check continuity between driver seat control unit harness connector and ground.

Driver seat control unit		Ground	Continuity
Connector	Terminal		
B503	32	Ground	Existed
B504	48		

Is the inspection result normal?

YES >> INSPECTION END

NO >> Repair or replace harness.

PASSENGER SEAT CONTROL UNIT

PASSENGER SEAT CONTROL UNIT : Diagnosis Procedure

INFOID:000000008157988

1.CHECK FUSE AND FUSIBLE LINK

Check that the following fuse is not fusing.

POWER SUPPLY AND GROUND CIRCUIT

< DTC/CIRCUIT DIAGNOSIS >

Terminal No.	Signal name	Fuse No.
40	Battery power supply	10 (10 A)

Is the inspection result normal?

YES >> GO TO 2.

NO >> Replace the blown fuse after repairing the affected circuit if a fuse is blown.

2.CHECK POWER SUPPLY 1

1. Turn ignition switch OFF.
2. Disconnect passenger seat control unit connector.
3. Check voltage between passenger seat control unit harness connector and ground.

(+)		(-)	Voltage (V) (Approx.)
Passenger seat control unit			
Connector	Terminal		
B553	40	Ground	Battery voltage

Is the inspection result normal?

YES >> GO TO 3.

NO >> Repair or replace harness.

3.CHECK POWER SUPPLY 2

Check voltage between passenger seat control unit harness connector and ground.

(+)		(-)	Voltage (V) (Approx.)
Passenger seat control unit			
Connector	Terminal		
B553	33	Ground	Battery voltage

Is the inspection result normal?

YES >> GO TO 4.

NO >> GO TO 5.

4.CHECK GROUND CIRCUIT

Check continuity between passenger seat control unit harness connector and ground.

Passenger seat control unit		Ground	Continuity
Connector	Terminal		
B552	32		Existed
B553	48		

Is the inspection result normal?

YES >> INSPECTION END

NO >> Repair or replace harness.

5.CHECK POWER SUPPLY CIRCUIT

1. Disconnect BCM connector.
2. Check continuity between BCM harness connector and passenger seat control unit harness connector.

Passenger seat control unit		BCM		Continuity
Connector	Terminal	Connector	Terminal	
B553	33	M118	2	Existed

3. Check continuity between passenger seat control unit harness connector and ground.

POWER SUPPLY AND GROUND CIRCUIT

< DTC/CIRCUIT DIAGNOSIS >

Passenger seat control unit	Terminal	Ground	Continuity
Connector			
B553	33		Not existed

Is the inspection result normal?

YES >> Replace BCM.Refer to @@@.

NO >> Repair or replace harness.

HEATED SEAT CONTROL UNIT

HEATED SEAT CONTROL UNIT : Diagnosis Procedure

INFOID:000000008157989

1.CHECK FUSE

Check that the following fuse is not fusing.

Signal name	Fuse No.
Battery power supply	35 (15 A)

Is the inspection result normal?

YES >> GO TO 2.

NO >> Replace the blown fuse after repairing the affected circuit if a fuse is blown.

2.CHECK POWER SUPPLY 1

1. Turn ignition switch OFF.
2. Disconnect heated seat control unit connector.
3. Turn ignition switch ON.
4. Check voltage between heated seat control unit harness connector and ground.

(+)		(-)	Voltage (V) (Approx.)
Heated seat control unit			
Connector	Terminal	Ground	Battery voltage
Driver side	B518		
Passenger side	B575		
	60		

Is the inspection result normal?

YES >> GO TO 4.

NO >> GO TO 3.

3.CHECK POWER SUPPLY CIRCUIT 1

1. Turn ignition switch OFF.
2. Disconnect heated seat relay.
3. Check continuity between heated seat control unit harness connector and heated seat relay terminal connector.

Heated seat control unit		Heated seat relay		Continuity
Connector	Terminal	Connector	Terminal	
Driver side	B518	E19	3	Existed
Passenger side	B575			
	60			

4. Check continuity between heated seat control unit harness connector and ground.

Heated seat control unit		Ground	Continuity
Connector	Terminal		
Driver side	B518	60	Not existed
Passenger side	B575		

Is the inspection result normal?

POWER SUPPLY AND GROUND CIRCUIT

< DTC/CIRCUIT DIAGNOSIS >

- YES >> Check heat seat relay. Refer to [SE-105. "Component Function Check"](#).
 NO >> Repair or replace harness.

4. CHECK POWER SUPPLY 2

Check voltage between heated seat control unit harness connector and ground.

(+)		Terminal	(-)	Condition	Voltage (V) (Approx.)	
Heated seat control unit						
Connector						
Driver side	B518	66	Ground	Heated seat switch	ON	Battery voltage
					OFF	0
Passenger side	B575			ON	Battery voltage	
				OFF	0	

Is the inspection result normal?

- YES >> GO TO 7.
 NO >> GO TO 5.

5. CHECK POWER SUPPLY CIRCUIT 2

- Turn ignition switch OFF.
- Disconnect heated seat switch connector.
- Check continuity between heated seat control unit harness connector and heated seat switch harness connector.

Heated seat control unit		Terminal	Heated seat switch		Continuity
Connector			Connector	Terminal	
Driver side	B518	66	A/T models: M141 M/T models: M175	1	Existed
Passenger side	B575		A/T models: M142 M/T models: M176		

- Check continuity between heated seat control unit harness connector and ground.

Heated seat control unit		Terminal	Ground	Continuity
Connector				
Driver side	B518	66		Not existed
Passenger side	B575			

Is the inspection result normal?

- YES >> GO TO 6.
 NO >> Repair or replace harness.

6. CHECK HEATED SEAT SWITCH

Check heated seat switch.

- Driver side: Refer to [SE-102. "DRIVER SIDE : Component Inspection"](#).
- Passenger side: Refer to [SE-104. "PASSENGER SIDE : Component Inspection"](#).

Is the inspection result normal?

- YES >> GO TO 8.
 NO >> Replace heated seat switch. Refer to [SE-231. "Removal and Installation"](#).

7. CHECK GROUND CIRCUIT

- Turn ignition switch OFF.
- Check continuity between heated seat control unit harness connector and ground.

POWER SUPPLY AND GROUND CIRCUIT

< DTC/CIRCUIT DIAGNOSIS >

Heated seat control unit		Terminal	Ground	Continuity
Connector				Existed
Driver side	B518	48		
Passenger side	B575			

Is the inspection result normal?

- YES >> INSPECTION END
 NO >> Repair or replace harness.

8.CHECK INTERMITTENT INCIDENT

Check intermittent incident.
 Refer to [GI-42, "Intermittent Incident"](#).

>> INSPECTION END

HEATED SEAT SWITCH

HEATED SEAT SWITCH : Diagnosis Procedure

INFOID:000000008157990

1.CHECK FUSE

Check that the following fuse is not fusing.

Terminal No.	Signal name	Fuse No.
5	Ignition power supply	3 (10 A)

Is the inspection result normal?

- YES >> GO TO 2.
 NO >> Replace the blown fuse after repairing the affected circuit if a fuse is blown.

2.CHECK POWER SUPPLY

- Turn ignition switch OFF.
- Disconnect heated seat switch connector.
- Turn ignition switch ON.
- Check voltage between heated seat switch harness connector and ground.

Heated seat switch		Terminal	(-)	Voltage (V) (Approx.)
Connector				
Driver side	A/T models: M141 M/T models: M175	5	Ground	Battery voltage
Passenger side	A/T models: M142 M/T models: M176			

Is the inspection result normal?

- YES >> INSPECTION END
 NO >> GO TO 3.

3.CHECK POWER SUPPLY CIRCUIT

- Turn ignition switch OFF.
- Disconnect fuse block (J/B) connector.
- Check continuity between heated seat switch harness connector and fuse block (J/B) harness connector.

POWER SUPPLY AND GROUND CIRCUIT

< DTC/CIRCUIT DIAGNOSIS >

Heated seat switch		Fuse block (J/B)		Continuity
Connector	Terminal	Connector	Terminal	
Driver side	A/T models: M141 M/T models: M175	M1	2A	Existed
Passenger side	A/T models: M142 M/T models: M176			

4. Check continuity between heated seat switch harness connector and ground.

Heated seat switch		Ground	Continuity
Connector	Terminal		
Driver side	A/T models: M141 M/T models: M175	5	Not existed
Passenger side	A/T models: M142 M/T models: M176		

Is the inspection result normal?

YES >> GO TO 4.

NO >> Repair or replace harness.

4.CHECK FUSE BLOCK (J/B)

1. Turn ignition switch ON.
2. Check voltage between fuse block (J/B) connector (fuse block side) and ground.

(+)		(-)	Voltage (V) (Approx.)
Connector	Terminal		
M1	2A	Ground	Battery voltage

Is the inspection result normal?

YES >> GO TO 5.

NO >> Repair or replace fuse block (J/B).

5.CHECK INTERMITTENT INCIDENT

Check intermittent incident.

Refer to [GI-42, "Intermittent Incident"](#)

>> INSPECTION END

CLIMATE CONTROLLED SEAT CONTROL UNIT

CLIMATE CONTROLLED SEAT CONTROL UNIT : Diagnosis Procedure

INFOID:000000008157991

Driver side

1.CHECK FUSE

Check that the following fuse and fusible link are not fusing.

Signal name	Fuse No.
Battery power supply	37(15A)
IGN power supply	3 (10A)

Is the fuse fusing?

YES >> Replace the blown fuse after repairing the affected circuit if a fuse are blown.

NO >> GO TO 2.

2.CHECK CLIMATE CONTROLLED SEAT CONTROL UNIT POWER SUPPLY 1

1. Turn ignition switch OFF.

POWER SUPPLY AND GROUND CIRCUIT

< DTC/CIRCUIT DIAGNOSIS >

2. Disconnect climate controlled seat control unit (driver side) connector.
3. Turn ignition switch ON.
4. Check voltage between climate controlled seat control unit (driver side) harness connector and ground.

(+)		(-)	Voltage (Approx.)
Climate controlled seat control unit (driver side)			
Connector	Terminal	Ground	Battery voltage
B606	89		
B607	93		

Is the measurement value normal?

- YES >> GO TO 3.
NO >> GO TO 4.

3.CHECK GROUND CIRCUIT

Check continuity between climate control unit (driver side) harness connector and ground.

Climate controlled seat control unit (driver side)		Ground	Continuity
Connector	Terminal		
B606	90		Existed

Does continuity exist?

- YES >> INSPECTION END
NO >> Repair or replace harness or connector.

4.CHECK CLIMATE CONTROLLED SEAT CONTROL UNIT POWER SUPPLY CIRCUIT 1

1. Turn ignition switch OFF.
2. Disconnect climate controlled seat relay.
3. Check continuity between climate controlled seat control unit (driver side) harness connector and climate controlled seat relay harness connector.

Climate controlled seat control unit (driver side)		Climate controlled seat relay		Continuity
Connector	Terminal	Connector	Terminal	
B606	89	E20	6	Existed
B607	93			

4. Check continuity between climate controlled seat control unit (driver side) harness connector and ground.

Climate controlled seat control unit (driver side)		Ground	Continuity
Connector	Terminal		
B606	89		Not existed
B607	93		

Is the measurement value normal?

- YES >> GO TO 5.
NO >> Repair or replace harness or connector.

5.CHECK CLIMATE CONTROLLED SEAT RELAY POWER SUPPLY CIRCUIT 2

1. Turn ignition switch ON.
2. Check voltage between climate controlled seat relay harness connector and ground.

POWER SUPPLY AND GROUND CIRCUIT

< DTC/CIRCUIT DIAGNOSIS >

Terminals		Voltage (Approx.)
(+)	(-)	
Climate controlled seat relay		Ground
Connector	Terminal	
E20	2 7	
		Battery voltage

Is the measurement value normal?

- YES >> GO TO 6.
NO >> Repair or replace harness or connector.

6.CHECK CLIMATE CONTROLLED SEAT RELAY

Check climate controlled seat relay.

Refer to [SE-48, "CLIMATE CONTROLLED SEAT CONTROL UNIT : Component Inspection"](#)

Is the inspection result normal?

- YES >> GO TO 7.
NO >> Replace climate controlled seat relay.

7.CHECK CLIMATE CONTROLLED SEAT RELAY GROUND CIRCUIT

Check continuity between climate controlled seat relay harness connector and ground.

Climate controlled seat relay		Ground	Continuity
Connector	Terminal		
E20	1		Existed

Does continuity exist?

- YES >> GO TO 8.
NO >> Repair or replace harness.

8.CHECK INTERMITTENT INCIDENT

Refer to [GI-42, "Intermittent Incident"](#).

>> INSPECTION END

Passenger side

1.CHECK FUSE

Check that the following fuses are not fusing.

Signal name	Fuse No.
Battery power supply	35 (15A)
IGN power supply	3 (10A)

Is the fuse fusing?

- YES >> Replace the blown fuse after repairing the affected circuit if a fuse is blown.
NO >> GO TO 2.

2.CHECK CLIMATE CONTROLLED SEAT CONTROL UNIT POWER SUPPLY

1. Turn ignition switch OFF.
2. Disconnect climate controlled seat control unit (passenger side) connector.
3. Turn ignition switch ON.
4. Check voltage between climate controlled seat control unit (passenger side) harness connector and ground.

POWER SUPPLY AND GROUND CIRCUIT

< DTC/CIRCUIT DIAGNOSIS >

(+)		(-)	Voltage (Approx.)
Climate controlled seat control unit (passenger side)			
Connector	Terminal	Ground	Battery voltage
B626	89		
B627	93		

Is the measurement value normal?

YES >> GO TO 3.

NO >> GO TO 4.

3. CHECK GROUND CIRCUIT

Check continuity between harness connector and ground.

Climate controlled seat control unit (passenger side)		Ground	Continuity
Connector	Terminal		
B626	90	Ground	Existed
B627	93		

Does continuity exist?

YES >> INSPECTION END

NO >> Repair harness or connector.

4. CHECK CLIMATE CONTROLLED SEAT CONTROL UNIT POWER SUPPLY CIRCUIT 1

1. Turn ignition switch OFF.
2. Disconnect climate controlled seat relay.
3. Check continuity between climate controlled seat control unit (passenger side) harness connector and climate controlled seat relay harness connector.

Climate controlled seat control unit (passenger side)		Climate controlled seat relay		Continuity
Connector	Terminal	Connector	Terminal	
B626	89	E20	3	Existed
B627	93			

4. Check continuity between climate controlled seat control unit (driver side) harness connector and ground.

Climate controlled seat control unit (driver side)		Ground	Continuity
Connector	Terminal		
B626	89	Ground	Not existed
B627	93		

Is the measurement value normal?

YES >> GO TO 5.

NO >> Repair or replace harness or connector.

5. CHECK CLIMATE CONTROLLED SEAT RELAY POWER SUPPLY CIRCUIT

1. Turn ignition switch ON.
2. Check voltage between climate controlled seat relay harness connector and ground.

Terminals		(-)	Voltage (Approx.)
(+)			
Climate controlled seat relay		Ground	Battery voltage
Connector	Terminal		
E20	2		
	5		

Is the measurement value normal?

POWER SUPPLY AND GROUND CIRCUIT

< DTC/CIRCUIT DIAGNOSIS >

- YES >> GO TO 6.
 NO >> Repair or replace harness or connector.

6. CHECK CLIMATE CONTROLLED SEAT RELAY

Check climate controlled seat relay.

Refer to [SE-48, "CLIMATE CONTROLLED SEAT CONTROL UNIT : Component Inspection"](#)

Is the inspection result normal?

- YES >> GO TO 7.
 NO >> Replace climate controlled seat relay.

7. CHECK CLIMATE CONTROLLED SEAT RELAY GROUND CIRCUIT

Check continuity between climate controlled seat relay harness connector and ground.

Climate controlled seat relay		Ground	Continuity
Connector	Terminal		
E20	1		Existed

Does continuity exist?

- YES >> GO TO 8.
 NO >> Repair or replace harness.

8. CHECK INTERMITTENT INCIDENT

Refer to [GI-42, "Intermittent Incident"](#).

>> INSPECTION END

CLIMATE CONTROLLED SEAT CONTROL UNIT : Component Inspection INFOID:000000008157992

1. CHECK CLIMATE CONTROLLED SEAT RELAY

1. Turn ignition switch OFF.
2. Disconnect climate controlled seat relay.
3. Check climate controlled seat relay.

Climate controlled seat relay		Condition	Continuity
Terminal			
3	5	12 V direct current supply between terminals 1 and 2.	Existed
		No current supply	Not existed
6	7	12 V direct current supply between terminals 1 and 2.	Existed
		No current supply	Not existed

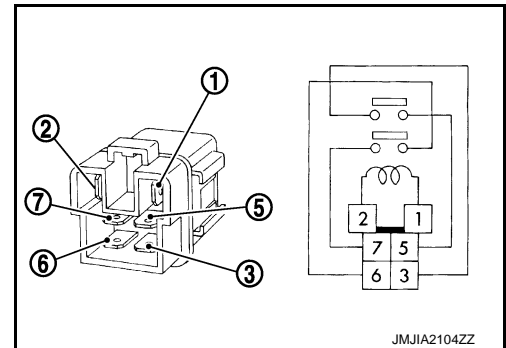

JMJIA2104ZZ

Is the inspection result normal?

- YES >> INSPECTION END.
 NO >> Replace climate controlled seat relay.

SLIDING SWITCH

< DTC/CIRCUIT DIAGNOSIS >

SLIDING SWITCH

DRIVER SIDE

DRIVER SIDE : Description

INFOID:000000008157993

- Sliding switch is equipped to the power seat switch on the seat cushion side surface.
- The operation signal is input to the driver seat control unit when the sliding switch is operated.

DRIVER SIDE : Component Function Check

INFOID:000000008157994

1.CHECK FUNCTION

1. Turn ignition switch ON.
2. Select "SLIDE SW-FR", "SLIDE SW-RR" in the "Data monitor" mode using CONSULT.
3. Check sliding switch signal under the following conditions.

Monitor item	Condition		Status
SLIDE SW-FR	Sliding switch (forward)	Operate	ON
		Release	OFF
SLIDE SW-RR	Sliding switch (backward)	Operate	ON
		Release	OFF

Is the indication normal?

- YES >> Sliding switch function is OK.
NO >> Refer to [SE-49, "DRIVER SIDE : Diagnosis Procedure"](#).

DRIVER SIDE : Diagnosis Procedure

INFOID:000000008157995

1.CHECK SLIDING SWITCH SIGNAL

1. Turn ignition switch OFF.
2. Disconnect power seat switch connector.
3. Check voltage between power seat switch harness connector and ground.

(+)		(-)	Voltage (V) (Approx.)
Power seat switch			
Connector	Terminal	Ground	Battery voltage
B511	11		
	26		

Is the inspection result normal?

- YES >> GO TO 3.
NO >> GO TO 2.

2.CHECK SLIDING SWITCH CIRCUIT

1. Disconnect driver seat control unit connector.
2. Check continuity between driver seat control unit harness connector and power seat switch harness connector.

Driver seat control unit		Power seat switch		Continuity
Connector	Terminal	Connector	Terminal	
B503	11	B511	11	Existed
	26		26	

3. Check continuity between driver seat control unit harness connector and ground.

SLIDING SWITCH

< DTC/CIRCUIT DIAGNOSIS >

Driver seat control unit		Ground	Continuity
Connector	Terminal		
B503	11		
	26		

Is the inspection result normal?

YES >> Replace driver seat control unit. Refer to [SE-224, "Removal and Installation"](#).

NO >> Repair or replace harness.

3.CHECK SLIDING SWITCH

Check sliding switch.

Refer to [SE-50, "DRIVER SIDE : Component Inspection"](#).

Is the inspection result normal?

YES >> GO TO 4.

NO >> Replace power seat switch. Refer to [SE-227, "Removal and Installation"](#).

4.CHECK INTERMITTENT INCIDENT

Check intermittent incident.

Refer to [GI-42, "Intermittent Incident"](#).

>> INSPECTION END

DRIVER SIDE : Component Inspection

INFOID:000000008157996

1.CHECK SLIDING SWITCH

1. Turn ignition switch OFF.
2. Disconnect power seat switch connector.
3. Check continuity between power seat switch terminals.

Power seat switch		Condition	Continuity
Terminal			
32	11	Backward	Existed
		Other than above	Not existed
	26	Forward	Existed
		Other than above	Not existed

Is the inspection result normal?

YES >> INSPECTION END

NO >> Replace power seat switch. Refer to [SE-227, "Removal and Installation"](#).

PASSENGER SIDE

PASSENGER SIDE : Description

INFOID:000000008157997

- Sliding switch is equipped to the power seat switch on the seat cushion side surface.
- The operation signal is input to the passenger seat control unit when the sliding switch is operated.

PASSENGER SIDE : Component Function Check

INFOID:000000008157998

1.CHECK FUNCTION

Check seat sliding operation with sliding switch.

Is the indication normal?

YES >> Sliding switch function is OK.

NO >> Refer to [SE-51, "PASSENGER SIDE : Diagnosis Procedure"](#).

SLIDING SWITCH

< DTC/CIRCUIT DIAGNOSIS >

PASSENGER SIDE : Diagnosis Procedure

INFOID:000000008157999

1. CHECK SLIDING SWITCH SIGNAL

1. Turn ignition switch OFF.
2. Check voltage between passenger seat control unit harness connector and ground.

(+)		(-)	Condition	Voltage (V) (Approx.)	
Passenger seat control unit					
Connector	Terminal				
B552	11	Ground	Sliding switch	Backward	0
				Other than above	Battery voltage
	26			Forward	0
				Other than above	Battery voltage

Is the inspection result normal?

- YES >> Sliding switch circuit is OK.
 NO >> GO TO 2.

2. CHECK SLIDING SWITCH INPUT SIGNAL

1. Disconnect power seat switch connector.
2. Check voltage between power seat switch harness connector and ground.

(+)		(-)	Voltage (V) (Approx.)
Power seat switch			
Connector	Terminal		
B554	22	Ground	Battery voltage
	23		

Is the inspection result normal?

- YES >> GO TO 4.
 NO >> GO TO 3.

3. CHECK SLIDING SWITCH CIRCUIT

1. Disconnect sliding switch (seatback) connector.
2. Check continuity between sliding switch (seatback) harness connector and power seat switch harness connector.

Sliding switch (seatback)		Power seat switch		Continuity
Connector	Terminal	Connector	Terminal	
B561	22	B554	22	Existed
	23		23	

3. Check continuity between sliding switch (seatback) harness connector and ground.

Sliding switch (seatback)		Ground	Continuity
Connector	Terminal		
B561	22		Not existed
	23		

Is the inspection result normal?

- YES >> GO TO 5.
 NO >> Repair or replace harness.

4. CHECK SLIDING SWITCH

Check sliding switch.

Refer to [SE-52, "PASSENGER SIDE : Component Inspection"](#).

SLIDING SWITCH

< DTC/CIRCUIT DIAGNOSIS >

Is the inspection result normal?

YES >> GO TO 6.

NO >> Replace power seat switch. Refer to [SE-227, "Removal and Installation"](#).

5.CHECK SLIDING SWITCH (SEATBACK)

Check sliding switch (seatback).

Refer to [SE-54, "SEATBACK : Component Inspection"](#).

Is the inspection result normal?

YES >> GO TO 6.

NO >> Replace sliding switch (seatback). Refer to [SE-199, "Exploded View"](#).

6.CHECK INTERMITTENT INCIDENT

Check intermittent incident.

Refer to [GI-42, "Intermittent Incident"](#).

>> INSPECTION END

PASSENGER SIDE : Component Inspection

INFOID:000000008158000

1.CHECK SLIDING SWITCH

1. Turn ignition switch OFF.
2. Disconnect power seat switch connector.
3. Check continuity between power seat switch terminals.

Power seat switch		Condition	Continuity
Terminal			
32	22	Forward	Existed
		Other than above	Not existed
	23	Backward	Existed
		Other than above	Not existed

Is the inspection result normal?

YES >> INSPECTION END

NO >> Replace power seat switch. Refer to [SE-227, "Removal and Installation"](#).

SEATBACK

SEATBACK : Description

INFOID:000000008158001

- Sliding switch is equipped on the seatback.
- The operation signal input to passenger seat control unit when sliding switch (seatback) is operated.

SEATBACK : Component Function Check

INFOID:000000008158002

1.CHECK FUNCTION

Check seat sliding operation with sliding switch (seatback).

Is the inspection result normal?

YES >> Sliding switch (seatback) function is OK.

NO >> Refer to [SE-52, "SEATBACK : Diagnosis Procedure"](#).

SEATBACK : Diagnosis Procedure

INFOID:000000008158003

1.CHECK SLIDING SWITCH (SEATBACK) SIGNAL

1. Turn ignition switch OFF.
2. Check voltage between passenger seat control unit harness connector and ground.

SLIDING SWITCH

< DTC/CIRCUIT DIAGNOSIS >

(+)		(-)	Condition	Voltage (V) (Approx.)	
Passenger seat control unit					
Connector	Terminal				
B552	11	Ground	Sliding switch (seatback)	Backward	0
			Other than above	Battery voltage	
	26		Forward	0	
			Other than above	Battery voltage	

Is the inspection result normal?

YES >> Sliding switch (seatback) circuit is OK.

NO >> GO TO 2.

2. CHECK SLIDING SWITCH (SEATBACK) CIRCUIT

1. Disconnect passenger seat control unit connector and sliding switch (seatback) connector.
2. Check continuity between passenger seat control unit harness connector and sliding switch (seatback) harness connector.

Passenger seat control unit		Sliding switch (seatback)		Continuity
Connector	Terminal	Connector	Terminal	
B552	11	B561	11	Existed
	26		26	

3. Check continuity between passenger seat control unit harness connector and ground.

Passenger seat control unit		Ground	Continuity
Connector	Terminal		
B552	11		Not existed
	26		

Is the inspection result normal?

YES >> GO TO 3.

NO >> Repair or replace harness.

3. CHECK SLIDING SWITCH (SEATBACK) GROUND CIRCUIT

Check continuity between sliding switch (seatback) harness connector and ground.

Sliding switch (seatback)		Ground	Continuity
Connector	Terminal		
B561	32		Existed

Is the inspection result normal?

YES >> GO TO 4.

NO >> Repair or replace harness.

4. CHECK SLIDING SWITCH (SEATBACK)

Check sliding switch (seatback).

Refer to [SE-54. "SEATBACK : Component Inspection"](#).

Is the inspection result normal?

YES >> GO TO 5.

NO >> Replace sliding switch (seatback). Refer to [SE-199. "Exploded View"](#).

5. CHECK PASSENGER SEAT CONTROL UNIT OUTPUT SIGNAL

1. Connect passenger seat control unit connector.
2. Check voltage between passenger seat control unit harness connector and ground.

SLIDING SWITCH

< DTC/CIRCUIT DIAGNOSIS >

(+)		(-)	Voltage (V) (Approx.)
Passenger seat control unit			
Connector	Terminal	Ground	Battery voltage
B552	11		
	26		

Is the inspection result normal?

YES >> GO TO 6.

NO >> Replace passenger seat control unit. Refer to [SE-225. "Removal and Installation"](#).

6.CHECK INTERMITTENT INCIDENT

Check intermittent incident.

Refer to [GI-42. "Intermittent Incident"](#).

>> INSPECTION END

SEATBACK : Component Inspection

INFOID:000000008158004

1.CHECK SLIDING SWITCH

1. Turn ignition switch OFF.
2. Disconnect sliding switch (seatback) connector.
3. Check continuity between sliding switch (seatback) terminals.

Sliding switch (seatback)		Condition	Continuity
Terminal			
32	11	Backward	Existed
	26	Other than above	Not existed
11		23	Forward
	26	22	Other than above
11		23	Backward
	Other than above		Existed
26	22	Forward	Not existed
		Other than above	Existed

Is the inspection result normal?

YES >> INSPECTION END

NO >> Replace sliding switch (seatback). Refer to [SE-199. "Exploded View"](#).

RECLINING SWITCH

< DTC/CIRCUIT DIAGNOSIS >

RECLINING SWITCH DRIVER SIDE

DRIVER SIDE : Description

INFOID:000000008158005

- Reclining switch is equipped to the power seat switch on the seat cushion side surface.
- The operation signal is input to the driver seat control unit when the reclining switch is operated.

DRIVER SIDE : Component Function Check

INFOID:000000008158006

1. CHECK FUNCTION

1. Turn ignition switch ON.
2. Select "RECLN SW-FR", "RECLN SW-RR" in the "Data monitor" mode using CONSULT.
3. Check reclining switch signal under the following conditions.

Monitor item	Condition		Status
RECLINE SW-FR	Reclining switch (forward)	Operate	ON
		Release	OFF
RECLINE SW-RR	Reclining switch (backward)	Operate	ON
		Release	OFF

Is the indication normal?

- YES >> Reclining switch function is OK.
 NO >> Refer to [SE-55, "DRIVER SIDE : Diagnosis Procedure"](#).

DRIVER SIDE : Diagnosis Procedure

INFOID:000000008158007

1. CHECK RECLINING SWITCH SIGNAL

1. Turn ignition switch OFF.
2. Disconnect power seat switch connector.
3. Check voltage between power seat switch harness connector and ground.

(+)		(-)	Voltage (V) (Approx.)
Power seat switch			
Connector	Terminal	Ground	Battery voltage
B511	12		
	27		

Is the inspection result normal?

- YES >> GO TO 3.
 NO >> GO TO 2.

2. CHECK RECLINING SWITCH CIRCUIT

1. Disconnect driver seat control unit connector.
2. Check continuity between driver seat control unit harness connector and power seat switch harness connector.

Driver seat control unit		Power seat switch		Continuity
Connector	Terminal	Connector	Terminal	
B503	12	B511	12	Existed
	27		27	

3. Check continuity between driver seat control unit harness connector and ground.

RECLINING SWITCH

< DTC/CIRCUIT DIAGNOSIS >

Driver seat control unit		Ground	Continuity
Connector	Terminal		
B503	12		Not existed
	27		

Is the inspection result normal?

- YES >> Replace driver seat control unit. Refer to [SE-224, "Removal and Installation"](#).
 NO >> Repair or replace harness.

3.CHECK RECLINING SWITCH

Check reclining switch.

Refer to [SE-56, "DRIVER SIDE : Component Inspection"](#).

Is the inspection result normal?

- YES >> GO TO 4.
 NO >> Replace power seat switch. Refer to [SE-227, "Removal and Installation"](#).

4.CHECK INTERMITTENT INCIDENT

Check intermittent incident.

Refer to [GI-42, "Intermittent Incident"](#).

>> INSPECTION END

DRIVER SIDE : Component Inspection

INFOID:000000008158008

1.CHECK RECLINING SWITCH

1. Turn ignition switch OFF.
2. Disconnect power seat switch connector.
3. Check continuity between power seat switch terminals.

Power seat switch		Condition	Continuity
Terminal			
32	12	Backward	Existed
		Other than above	Not existed
	27	Forward	Existed
		Other than above	Not existed

Is the inspection result normal?

- YES >> INSPECTION END
 NO >> Replace power seat switch. Refer to [SE-227, "Removal and Installation"](#).

PASSENGER SIDE

PASSENGER SIDE : Description

INFOID:000000008158009

- Reclining switch is equipped to the power seat switch on the seat cushion side surface.
- The operation signal is input to the passenger seat control unit when the reclining switch is operated.

PASSENGER SIDE : Component Function Check

INFOID:000000008158010

1.CHECK FUNCTION

Check seat reclining operation with reclining switch.

Is the indication normal?

- YES >> Reclining switch function is OK.
 NO >> Refer to [SE-57, "PASSENGER SIDE : Diagnosis Procedure"](#).

RECLINING SWITCH

< DTC/CIRCUIT DIAGNOSIS >

PASSENGER SIDE : Diagnosis Procedure

INFOID:000000008158011

1. CHECK RECLINING SWITCH SIGNAL

1. Turn ignition switch OFF.
2. Check voltage between passenger seat control unit harness connector and ground.

(+)		(-)	Condition	Voltage (V) (Approx.)
Passenger seat control unit				
Connector	Terminal			
B552	12	Ground	Backward	0
			Other than above	Battery voltage
	27		Forward	0
			Other than above	Battery voltage

Is the inspection result normal?

- YES >> Reclining switch circuit is OK.
 NO >> GO TO 2.

2. CHECK RECLINING SWITCH CIRCUIT

1. Disconnect passenger seat control unit connector and power seat switch connector.
2. Check continuity between passenger seat control unit harness connector and power seat switch harness connector.

Passenger seat control unit		Power seat switch		Continuity
Connector	Terminal	Connector	Terminal	
B552	12	B554	12	Existed
	27		27	

3. Check continuity between passenger seat control unit harness connector and ground.

Passenger seat control unit		Ground	Continuity
Connector	Terminal		
B552	12		Not existed
	27		

Is the inspection result normal?

- YES >> GO TO 3.
 NO >> Repair or replace harness.

3. CHECK RECLINING SWITCH

Check reclining switch.

Refer to [SE-58, "PASSENGER SIDE : Component Inspection"](#).

Is the inspection result normal?

- YES >> GO TO 4.
 NO >> Replace power seat switch. Refer to [SE-227, "Removal and Installation"](#).

4. CHECK PASSENGER SEAT CONTROL UNIT OUTPUT SIGNAL

1. Connect passenger seat control unit connector.
2. Check voltage between passenger seat control unit harness connector and ground.

(+)		(-)	Voltage (V) (Approx.)
Passenger seat control unit			
Connector	Terminal		
B552	12	Ground	Battery voltage
	27		

RECLINING SWITCH

< DTC/CIRCUIT DIAGNOSIS >

Is the inspection result normal?

YES >> GO TO 5.

NO >> Replace passenger seat control unit. Refer to [SE-225, "Removal and Installation"](#).

5.CHECK INTERMITTENT INCIDENT

Check intermittent incident.

Refer to [GI-42, "Intermittent Incident"](#).

>> INSPECTION END

PASSENGER SIDE : Component Inspection

INFOID:000000008158012

1.CHECK RECLINING SWITCH

1. Turn ignition switch OFF.
2. Disconnect power seat switch connector.
3. Check continuity between power seat switch terminals.

Power seat switch		Condition	Continuity
Terminal			
32	12	Backward	Existed
		Other than above	Not existed
	27	Forward	Existed
		Other than above	Not existed

Is the inspection result normal?

YES >> INSPECTION END

NO >> Replace power seat switch. Refer to [SE-227, "Removal and Installation"](#).

LIFTING SWITCH (FRONT)

< DTC/CIRCUIT DIAGNOSIS >

LIFTING SWITCH (FRONT)

DRIVER SIDE

DRIVER SIDE : Description

INFOID:000000008158013

- Lifting switch (front) is equipped to the power seat switch on the seat cushion side surface.
- The operation signal is input to the driver seat control unit when the lifting switch (front) is operated.

DRIVER SIDE : Component Function Check

INFOID:000000008158014

1.CHECK FUNCTION

1. Turn ignition switch ON.
2. Select "LIFT FR SW-UP", "LIFT FR SW-DN" in the "Data monitor" mode using CONSULT.
3. Check lifting switch (front) signal under the following conditions.

Monitor item	Condition		Status
LIFT FR SW-UP	Lifting switch front (up)	Operate	ON
		Release	OFF
LIFT FR SW-DN	Lifting switch front (down)	Operate	ON
		Release	OFF

Is the indication normal?

YES >> Lifting switch (front) function is OK.

NO >> Refer to [SE-59, "DRIVER SIDE : Diagnosis Procedure"](#).

DRIVER SIDE : Diagnosis Procedure

INFOID:000000008158015

1.CHECK LIFTING SWITCH (FRONT) SIGNAL

1. Turn ignition switch OFF.
2. Disconnect power seat switch connector.
3. Check voltage between power seat switch harness connector and ground.

(+)		(-)	Voltage (V) (Approx.)
Power seat switch			
Connector	Terminal	Ground	Battery voltage
B511	13		
	28		

Is the inspection result normal?

YES >> GO TO 3.

NO >> GO TO 2.

2.CHECK LIFTING SWITCH (FRONT) CIRCUIT

1. Disconnect driver seat control unit connector.
2. Check continuity between driver seat control unit harness connector and power seat switch harness connector.

Driver seat control unit		Power seat switch		Continuity
Connector	Terminal	Connector	Terminal	
B503	13	B511	13	Existed
	28		28	

3. Check continuity between driver seat control unit harness connector and ground.

LIFTING SWITCH (FRONT)

< DTC/CIRCUIT DIAGNOSIS >

Driver seat control unit		Ground	Continuity
Connector	Terminal		
B503	13		Not existed
	28		

Is the inspection result normal?

YES >> Replace driver seat control unit. Refer to [SE-224, "Removal and Installation"](#).

NO >> Repair or replace harness.

3.CHECK LIFTING SWITCH (FRONT)

Check lifting switch (front).

Refer to [SE-60, "DRIVER SIDE : Component Inspection"](#).

Is the inspection result normal?

YES >> GO TO 4.

NO >> Replace power seat switch. Refer to [SE-227, "Removal and Installation"](#).

4.CHECK INTERMITTENT INCIDENT

Check intermittent incident.

Refer to [GI-42, "Intermittent Incident"](#).

>> INSPECTION END

DRIVER SIDE : Component Inspection

INFOID:000000008158016

1.CHECK LIFTING SWITCH (FRONT)

1. Turn ignition switch OFF.
2. Disconnect power seat switch connector.
3. Check continuity between power seat switch terminals.

Power seat switch		Condition	Continuity
Terminal			
32	13	Down	Existed
		Other than above	Not existed
	28	Up	Existed
		Other than above	Not existed

Is the inspection result normal?

YES >> INSPECTION END

NO >> Replace power seat switch. Refer to [SE-227, "Removal and Installation"](#).

PASSENGER SIDE

PASSENGER SIDE : Description

INFOID:000000008158017

- Lifting switch (front) is equipped to the power seat switch on the seat cushion side surface.
- The operation signal is input to the passenger seat control unit when the lifting switch (front) is operated.

PASSENGER SIDE : Component Function Check

INFOID:000000008158018

1.CHECK FUNCTION

Check seat lifting (front) operation with lifting switch (front).

Is the indication normal?

YES >> Lifting switch (front) function is OK.

NO >> Refer to [SE-61, "PASSENGER SIDE : Diagnosis Procedure"](#).

LIFTING SWITCH (FRONT)

< DTC/CIRCUIT DIAGNOSIS >

PASSENGER SIDE : Diagnosis Procedure

INFOID:000000008158019

1. CHECK LIFTING SWITCH (FRONT) SIGNAL

1. Turn ignition switch OFF.
2. Check voltage between passenger seat control unit harness connector and ground.

(+)		(-)	Condition	Voltage (V) (Approx.)
Passenger seat control unit				
Connector	Terminal			
B552	13	Ground	Down	0
			Other than above	Battery voltage
	28		UP	0
			Other than above	Battery voltage

Is the inspection result normal?

- YES >> Lifting switch (front) circuit is OK.
 NO >> GO TO 2.

2. CHECK LIFTING SWITCH (FRONT) CIRCUIT

1. Disconnect passenger seat control unit connector and power seat switch connector.
2. Check continuity between passenger seat control unit harness connector and power seat switch harness connector.

Passenger seat control unit		Power seat switch		Continuity
Connector	Terminal	Connector	Terminal	
B552	13	B554	13	Existed
	28		28	

3. Check continuity between passenger seat control unit harness connector and ground.

Passenger seat control unit		Ground	Continuity
Connector	Terminal		
B552	13		Not existed
	28		

Is the inspection result normal?

- YES >> GO TO 3.
 NO >> Repair or replace harness.

3. CHECK LIFTING SWITCH (FRONT)

Check lifting switch (front).

Refer to [SE-62, "PASSENGER SIDE : Component Inspection"](#).

Is the inspection result normal?

- YES >> GO TO 4.
 NO >> Replace power seat switch. Refer to [SE-227, "Removal and Installation"](#).

4. CHECK PASSENGER SEAT CONTROL UNIT OUTPUT SIGNAL

1. Connect passenger seat control unit connector.
2. Check voltage between passenger seat control unit harness connector and ground.

(+)		(-)	Voltage (V) (Approx.)
Passenger seat control unit			
Connector	Terminal		
B552	13	Ground	Battery voltage
	28		

LIFTING SWITCH (FRONT)

< DTC/CIRCUIT DIAGNOSIS >

Is the inspection result normal?

YES >> GO TO 5.

NO >> Replace passenger seat control unit. Refer to [SE-225, "Removal and Installation"](#).

5.CHECK INTERMITTENT INCIDENT

Check intermittent incident.

Refer to [GI-42, "Intermittent Incident"](#).

>> INSPECTION END

PASSENGER SIDE : Component Inspection

INFOID:000000008158020

1.CHECK LIFTING SWITCH (FRONT)

1. Turn ignition switch OFF.
2. Disconnect power seat switch connector.
3. Check continuity between power seat switch terminals.

Power seat switch		Condition	Continuity
Terminal			
32	13	Down	Existed
		Other than above	Not existed
	28	Up	Existed
		Other than above	Not existed

Is the inspection result normal?

YES >> INSPECTION END

NO >> Replace power seat switch. Refer to [SE-227, "Removal and Installation"](#).

LIFTING SWITCH (REAR)

< DTC/CIRCUIT DIAGNOSIS >

LIFTING SWITCH (REAR)

DRIVER SIDE

DRIVER SIDE : Description

INFOID:000000008158021

- Lifting switch (rear) is equipped to the power seat switch on the seat cushion side surface.
- The operation signal is input to the driver seat control unit when the lifting switch (rear) is operated.

DRIVER SIDE : Component Function Check

INFOID:000000008158022

1.CHECK FUNCTION

1. Turn ignition switch ON.
2. Select "LIFT RR SW-UP", "LIFT RR SW-DN" in the "Data monitor" mode using CONSULT.
3. Check lifting switch (rear) signal under the following conditions.

Monitor item	Condition		Status
LIFT RR SW-UP	Lifting switch rear (up)	Operate	ON
		Release	OFF
LIFT RR SW-DN	Lifting switch rear (down)	Operate	ON
		Release	OFF

Is the indication normal?

YES >> Lifting switch (rear) function is OK.

NO >> Refer to [SE-63, "DRIVER SIDE : Diagnosis Procedure"](#).

DRIVER SIDE : Diagnosis Procedure

INFOID:000000008158023

1.CHECK LIFTING SWITCH (REAR) SIGNAL

1. Turn ignition switch OFF.
2. Disconnect power seat switch connector.
3. Check voltage between power seat switch harness connector and ground.

(+)		(-)	Voltage (V) (Approx.)
Power seat switch			
Connector	Terminal	Ground	Battery voltage
B511	14		
	29		

Is the inspection result normal?

YES >> GO TO 3.

NO >> GO TO 2.

2.CHECK LIFTING SWITCH (REAR) CIRCUIT

1. Disconnect driver seat control unit connector.
2. Check continuity between driver seat control unit harness connector and power seat switch harness connector.

Driver seat control unit		Power seat switch		Continuity
Connector	Terminal	Connector	Terminal	
B503	14	B511	14	Existed
	29		29	

3. Check continuity between driver seat control unit harness connector and ground.

LIFTING SWITCH (REAR)

< DTC/CIRCUIT DIAGNOSIS >

Driver seat control unit		Ground	Continuity
Connector	Terminal		
B503	14		Not existed
	29		

Is the inspection result normal?

YES >> Replace driver seat control unit. Refer to [SE-224, "Removal and Installation"](#).

NO >> Repair or replace harness.

3.CHECK LIFTING SWITCH (REAR)

Check lifting switch (rear).

Refer to [SE-64, "DRIVER SIDE : Component Inspection"](#).

Is the inspection result normal?

YES >> GO TO 4.

NO >> Replace power seat switch. Refer to [SE-227, "Removal and Installation"](#).

4.CHECK INTERMITTENT INCIDENT

Check intermittent incident.

Refer to [GI-42, "Intermittent Incident"](#).

>> INSPECTION END

DRIVER SIDE : Component Inspection

INFOID:000000008158024

1.CHECK LIFTING SWITCH (REAR)

1. Turn ignition switch OFF.
2. Disconnect power seat switch connector.
3. Check continuity between power seat switch terminals.

Power seat switch		Condition	Continuity
Terminal			
32	14	Down	Existed
		Other than above	Not existed
	29	Up	Existed
		Other than above	Not existed

Is the inspection result normal?

YES >> INSPECTION END

NO >> Replace power seat switch. Refer to [SE-227, "Removal and Installation"](#).

PASSENGER SIDE

PASSENGER SIDE : Description

INFOID:000000008158025

- Lifting switch (rear) is equipped to the power seat switch on the seat cushion side surface.
- The operation signal is input to the passenger seat control unit when the lifting switch (rear) is operated.

PASSENGER SIDE : Component Function Check

INFOID:000000008158026

1.CHECK FUNCTION

Check seat lifting (rear) operation with lifting switch (rear).

Is the indication normal?

YES >> Lifting switch (rear) function is OK.

NO >> Refer to [SE-65, "PASSENGER SIDE : Diagnosis Procedure"](#).

LIFTING SWITCH (REAR)

< DTC/CIRCUIT DIAGNOSIS >

PASSENGER SIDE : Diagnosis Procedure

INFOID:000000008158027

1. CHECK LIFTING SWITCH (REAR) SIGNAL

1. Turn ignition switch OFF.
2. Check voltage between passenger seat control unit harness connector and ground.

(+)		(-)	Condition	Voltage (V) (Approx.)
Passenger seat control unit				
Connector	Terminal			
B552	14	Ground	Lifting switch (front) Down	0
			Lifting switch (front) Other than above	Battery voltage
	29		Lifting switch (front) Up	0
			Lifting switch (front) Other than above	Battery voltage

Is the inspection result normal?

- YES >> Lifting switch (front) circuit is OK.
 NO >> GO TO 2.

2. CHECK LIFTING SWITCH (REAR) CIRCUIT

1. Disconnect passenger seat control unit connector and power seat switch connector.
2. Check continuity between passenger seat control unit harness connector and power seat switch harness connector.

Passenger seat control unit		Power seat switch		Continuity
Connector	Terminal	Connector	Terminal	
B552	14	B554	14	Existed
	29		29	

3. Check continuity between passenger seat control unit harness connector and ground.

Passenger seat control unit		Ground	Continuity
Connector	Terminal		
B552	14		Not existed
	29		

Is the inspection result normal?

- YES >> GO TO 3.
 NO >> Repair or replace harness.

3. CHECK LIFTING SWITCH (REAR)

Check lifting switch (rear).

Refer to [SE-66, "PASSENGER SIDE : Component Inspection"](#).

Is the inspection result normal?

- YES >> GO TO 4.
 NO >> Replace power seat switch. Refer to [SE-227, "Removal and Installation"](#).

4. CHECK PASSENGER SEAT CONTROL UNIT OUTPUT SIGNAL

1. Connect passenger seat control unit connector.
2. Check voltage between passenger seat control unit harness connector and ground.

(+)		(-)	Voltage (V) (Approx.)
Passenger seat control unit			
Connector	Terminal		
B552	14	Ground	Battery voltage
	29		

LIFTING SWITCH (REAR)

< DTC/CIRCUIT DIAGNOSIS >

Is the inspection result normal?

YES >> GO TO 5.

NO >> Replace passenger seat control unit. Refer to [SE-225, "Removal and Installation"](#).

5.CHECK INTERMITTENT INCIDENT

Check intermittent incident.

Refer to [GI-42, "Intermittent Incident"](#).

>> INSPECTION END

PASSENGER SIDE : Component Inspection

INFOID:000000008158028

1.CHECK LIFTING SWITCH (REAR)

1. Turn ignition switch OFF.
2. Disconnect power seat switch connector.
3. Check continuity between power seat switch terminals.

Power seat switch		Condition	Continuity
Terminal			
32	14	Down	Existed
		Other than above	Not existed
	29	Up	Existed
		Other than above	Not existed

Is the inspection result normal?

YES >> INSPECTION END

NO >> Replace power seat switch. Refer to [SE-227, "Removal and Installation"](#).

POWER SEAT SWITCH GROUND CIRCUIT

< DTC/CIRCUIT DIAGNOSIS >

POWER SEAT SWITCH GROUND CIRCUIT DRIVER SIDE

DRIVER SIDE : Diagnosis Procedure

INFOID:000000008158029

1.CHECK POWER SEAT SWITCH GROUND CIRCUIT

1. Turn ignition switch OFF.
2. Disconnect power seat switch connector.
3. Check continuity between power seat switch connector and ground.

Power seat switch		Ground	Continuity
Connector	Terminal		
B511	32		Existed

Is the inspection result normal?

- YES >> GO TO 2.
NO >> Repair or replace harness.

2.CHECK POWER SEAT SWITCH INTERNAL CIRCUIT

Check lifting switch (rear).

Refer to [SE-64, "DRIVER SIDE : Component Inspection"](#).

Is the inspection result normal?

- YES >> GO TO 3.
NO >> Replace power seat switch. Refer to [SE-227, "Removal and Installation"](#).

3.CHECK INTERMITTENT INCIDENT

Check intermittent incident.

Refer to [GI-42, "Intermittent Incident"](#).

>> INSPECTION END

PASSENGER SIDE

PASSENGER SIDE : Diagnosis Procedure

INFOID:000000008158030

1.CHECK POWER SEAT SWITCH GROUND CIRCUIT

1. Turn ignition switch OFF.
2. Disconnect power seat switch connector.
3. Check continuity between power seat switch connector and ground.

Power seat switch		Ground	Continuity
Connector	Terminal		
B554	32		Existed

Is the inspection result normal?

- YES-1:When power seat switch does not operate any components.>>GO TO 2.
YES-2:When all power seat components do not operate.>>GO TO 3.
NO >> Repair or replace harness.

2.CHECK POWER SEAT SWITCH INTERNAL CIRCUIT

Check sliding switch.

Refer to [SE-52, "PASSENGER SIDE : Component Inspection"](#).

Is the inspection result normal?

- YES >> GO TO 3.
NO >> Replace power seat switch. Refer to [SE-227, "Removal and Installation"](#).

3.CHECK INTERMITTENT INCIDENT

A
B
C
D
E
F
G
H
I
SE
K
L
M
N
O
P

POWER SEAT SWITCH GROUND CIRCUIT

< DTC/CIRCUIT DIAGNOSIS >

Check intermittent incident.

Refer to [GI-42, "Intermittent Incident"](#).

>> INSPECTION END

FORWARD SWITCH

< DTC/CIRCUIT DIAGNOSIS >

FORWARD SWITCH DRIVER SIDE

DRIVER SIDE : Description

INFOID:000000008158031

- Forward switch is installed on the seatback frame.
- Forward switch detects condition of seatback.

DRIVER SIDE : Component Function Check

INFOID:000000008158032

1. CHECK FUNCTION

1. Turn ignition switch ON.
2. Select "FORWARD SW" in the "Data Monitor" mode using CONSULT.
3. Check the forward switch signal under the following condition.

Test item	Condition		Status
FORWARD SW	Driver side seatback	Folded up	ON
		Folded down	OFF

Is the indication normal?

- YES >> Forward switch function is OK.
 NO >> Refer to [SE-69, "DRIVER SIDE : Diagnosis Procedure"](#).

DRIVER SIDE : Diagnosis Procedure

INFOID:000000008158033

1. CHECK FORWARD SWITCH INPUT SIGNAL

1. Turn ignition switch OFF.
2. Disconnect forward switch connector.
3. Check voltage between forward switch harness connector and ground.

(+)		(-)	Condition	Voltage (V) (Approx.)
Forward switch				
Connector	Terminal			
B512	41	Ground	Not in the sleep mode	5

Is the inspection result normal?

- YES >> GO TO 3.
 NO >> GO TO 2.

2. CHECK FORWARD SWITCH CIRCUIT

1. Disconnect driver seat control unit connector.
2. Check continuity between driver seat control unit harness connector and forward switch harness connector.

Driver seat control unit		Forward switch		Continuity
Connector	Terminal	Connector	Terminal	
B504	41	B512	41	Existed

3. Check continuity between driver seat control unit harness connector and ground.

Driver seat control unit		Ground	Continuity
Connector	Terminal		
B504	41		Not existed

Is the inspection result normal?

- YES >> Replace driver seat control unit. Refer to [SE-224, "Removal and Installation"](#)
 NO >> Repair or replace harness.

FORWARD SWITCH

< DTC/CIRCUIT DIAGNOSIS >

3.CHECK FORWARD SWITCH GROUND CIRCUIT

Check continuity between forward switch harness connector and ground.

Forward switch		Ground	Continuity
Connector	Terminal		
B512	32		Existed

Is the inspection result normal?

- YES >> GO TO 4.
- NO >> Repair or replace harness.

4.CHECK FORWARD SWITCH

Check forward switch.

Refer to [SE-70, "DRIVER SIDE : Component Inspection"](#).

Is the inspection result normal?

- YES >> GO TO 5.
- NO >> Replace forward switch. Refer to [SE-199, "Exploded View"](#).

5.CHECK INTERMITTENT INCIDENT

Check intermittent incident.

Refer to [GI-42, "Intermittent Incident"](#).

>> INSPECTION END

DRIVER SIDE : Component Inspection

INFOID:000000008158034

1.CHECK FORWARD SWITCH

1. Turn ignition switch OFF.
2. Disconnect forward switch connector.
3. Check continuity between forward switch terminals.

Forward switch		Condition	Continuity
Terminal			
41	32	Driver side seatback	Folded up Not existed
			Folded down Existed

Is the inspection result normal?

- YES >> INSPECTION END
- NO >> Replace forward switch. Refer to [SE-199, "Exploded View"](#).

PASSENGER SIDE

PASSENGER SIDE : Description

INFOID:000000008158035

- Forward switch is installed on seatback frame.
- Forward switch detects condition of seatback.

PASSENGER SIDE : Component Function Check

INFOID:000000008158036

1.CHECK FUNCTION

Check that power walk-in function does not activate when seatback is folded up.

Is the inspection result normal?

- YES >> Forward switch function is OK.
- NO >> Refer to [SE-71, "PASSENGER SIDE : Diagnosis Procedure"](#).

FORWARD SWITCH

< DTC/CIRCUIT DIAGNOSIS >

PASSENGER SIDE : Diagnosis Procedure

INFOID:000000008158037

1. CHECK FORWARD SWITCH INPUT SIGNAL

1. Turn ignition switch OFF.
2. Check voltage between passenger seat control unit harness connector and ground.

(+)		(-)	Condition	Voltage (V) (Approx.)
Passenger seat control unit				
Connector	Terminal			
B553	41	Ground	Seatback is folded up and not in the sleep mode	5
			Other than above	0

Is the inspection result normal?

- YES >> Forward switch circuit is OK.
NO >> GO TO 2.

2. CHECK FORWARD SWITCH CIRCUIT

1. Disconnect passenger seat control unit connector and forward switch connector.
2. Check continuity between passenger seat control unit harness connector and forward switch harness connector.

Passenger seat control unit		Forward switch		Continuity
Connector	Terminal	Connector	Terminal	
B553	41	B556	41	Existed

3. Check continuity between passenger seat control unit harness connector and ground.

Passenger seat control unit		Ground	Continuity
Connector	Terminal		
B553	41		Not existed

Is the inspection result normal?

- YES >> GO TO 3.
NO >> Repair or replace harness.

3. FORWARD SWITCH GROUND CIRCUIT

Check continuity between forward switch harness connector and ground.

Forward switch		Ground	Continuity
Connector	Terminal		
B556	32		Existed

Is the inspection result normal?

- YES >> GO TO 4.
NO >> Repair or replace harness.

4. CHECK FORWARD SWITCH

Check forward switch.

Refer to [SE-72. "PASSENGER SIDE : Component Inspection"](#).

Is the inspection result normal?

- YES >> GO TO 5.
NO >> Replace forward switch. Refer to [SE-199. "Exploded View"](#).

5. CHECK PASSENGER SEAT CONTROL UNIT OUTPUT SIGNAL

1. Connect passenger seat control unit connector.
2. Check voltage between passenger seat control unit harness connector and ground.

FORWARD SWITCH

< DTC/CIRCUIT DIAGNOSIS >

(+)		(-)	Condition	Voltage (V) (Approx.)
Passenger seat control unit				
Connector	Terminal			
B553	41	Ground	Not in the sleep mode	5

Is the inspection result normal?

YES >> GO TO 6.

NO >> Replace passenger seat control unit. Refer to [SE-225, "Removal and Installation"](#).

6.CHECK INTERMITTENT INCIDENT

Check intermittent incident.

Refer to [GI-42, "Intermittent Incident"](#).

>> INSPECTION END

PASSENGER SIDE : Component Inspection

INFOID:000000008158038

1.CHECK FORWARD SWITCH

1. Turn ignition switch OFF.
2. Disconnect forward switch connector.
3. Check continuity between forward switch terminals.

Forward switch		Condition	Continuity	
Terminal				
32	41	Passenger side seatback	Folded up	Not existed
			Folded down	Existed

Is the inspection result normal?

YES >> INSPECTION END

NO >> Replace forward switch. Refer to [SE-199, "Exploded View"](#).

SEAT BELT BUCKLE SWITCH

< DTC/CIRCUIT DIAGNOSIS >

SEAT BELT BUCKLE SWITCH

DRIVER SIDE

DRIVER SIDE : Description

INFOID:000000008158039

- Seat belt buckle switch is installed in seat belt buckle.
- Seat belt buckle switch detects condition of seat belt.

DRIVER SIDE : Component Function Check

INFOID:000000008158040

1. CHECK FUNCTION

1. Turn ignition switch ON.
2. Select "SEAT BELT SW" in the "Data Monitor" mode using CONSULT.
3. Check the forward switch signal under the following condition.

Test item	Condition		Status
SEAT BELT SW	Driver side seat belt	Fastened	ON
		Released	OFF

Is the indication normal?

- YES >> Seat belt buckle switch (driver side) function is OK.
NO >> Refer to [SE-73, "DRIVER SIDE : Diagnosis Procedure"](#).

DRIVER SIDE : Diagnosis Procedure

INFOID:000000008158041

1. CHECK SEAT BELT BUCKLE SWITCH (DRIVER SIDE) INPUT SIGNAL

1. Turn ignition switch OFF.
2. Disconnect seat belt buckle switch (driver side) connector.
3. Check voltage between seat belt buckle switch (driver side) harness connector and ground.

(+)		(-)	Condition	Voltage (V) (Approx.)
Seat belt buckle switch (driver side)				
Connector	Terminal			
B13	1	Ground	Not in the sleep mode	5

Is the inspection result normal?

- YES >> GO TO 3.
NO >> GO TO 2.

2. CHECK SEAT BELT BUCKLE SWITCH (DRIVER SIDE) CIRCUIT

1. Disconnect driver seat control unit connector.
2. Check continuity between driver seat control unit harness connector and seat belt buckle switch (driver side) harness connector.

Driver seat control unit		Seat belt buckle switch (driver side)		Continuity
Connector	Terminal	Connector	Terminal	
B503	5	B13	1	Existed

3. Check continuity between driver seat control unit harness connector and ground.

Driver seat control unit		Ground	Continuity
Connector	Terminal		
B503	5		Not existed

Is the inspection result normal?

- YES >> Replace driver seat control unit. Refer to [SE-224, "Removal and Installation"](#).
NO >> Repair or replace harness.

SEAT BELT BUCKLE SWITCH

< DTC/CIRCUIT DIAGNOSIS >

3.CHECK SEAT BELT BUCKLE SWITCH (DRIVER SIDE) GROUND CIRCUIT

Check continuity between seat belt buckle switch (driver side) harness connector and ground.

Seat belt buckle switch (driver side)		Ground	Continuity
Connector	Terminal		
B13	2		Existed

Is the inspection result normal?

- YES >> GO TO 4.
- NO >> Repair or replace harness.

4.CHECK SEAT BELT BUCKLE SWITCH

Check seat belt buckle switch (driver side).
Refer to [SE-74, "DRIVER SIDE : Component Inspection"](#).

Is the inspection result normal?

- YES >> GO TO 5.
- NO >> Replace seat belt buckle switch (driver side). Refer to [SE-199, "Exploded View"](#).

5.CHECK INTERMITTENT INCIDENT

Check intermittent incident.
Refer to [GI-42, "Intermittent Incident"](#).

>> INSPECTION END

DRIVER SIDE : Component Inspection

INFOID:000000008158042

1.CHECK SEAT BELT BUCKLE SWITCH (DRIVER SIDE)

1. Turn ignition switch OFF.
2. Disconnect seat belt buckle switch (driver side) connector.
3. Check continuity between seat belt buckle switch (driver side) terminals.

Seat belt buckle switch (driver side)		Condition	Continuity
Terminal			
1	2	Driver side seat belt Fastened	Not existed
		Released	Existed

Is the inspection result normal?

- YES >> INSPECTION END
- NO >> Replace seat belt buckle switch (driver side). Refer to [SE-199, "Exploded View"](#).

PASSENGER SIDE

PASSENGER SIDE : Description

INFOID:000000008158043

- Seat belt buckle switch is installed in seat belt buckle.
- Seat belt buckle switch detects condition of seat belt.

PASSENGER SIDE : Component Function Check

INFOID:000000008158044

1.CHECK FUNCTION

Check that power walk-in function does not activate when seat belt is fastened.

Is the inspection result normal?

- YES >> Seat belt buckle switch (passenger side) is OK.
- NO >> Refer to [SE-75, "PASSENGER SIDE : Diagnosis Procedure"](#).

SEAT BELT BUCKLE SWITCH

< DTC/CIRCUIT DIAGNOSIS >

PASSENGER SIDE : Diagnosis Procedure

INFOID:000000008158045

1. CHECK SEAT BELT BUCKLE SWITCH SIGNAL

1. Turn ignition switch OFF.
2. Check voltage between passenger seat control unit harness connector and ground.

(+)		(-)	Condition	Voltage (V) (Approx.)
Passenger seat control unit				
Connector	Terminal			
B552	5	Ground	Passenger side seat belt is fastened, and not in the sleep mode	5
			Other than above	0

Is the inspection result normal?

YES >> Seat belt buckle switch (passenger side) circuit is OK.

NO >> GO TO 2.

2. CHECK SEAT BELT BUCKLE SWITCH (PASSENGER SIDE) CIRCUIT

1. Disconnect passenger seat control unit connector and seat belt buckle switch (passenger side) connector.
2. Check continuity between passenger seat control unit harness connector and seat belt buckle switch (passenger side) harness connector.

Passenger seat control unit		Seat belt buckle switch (passenger side)		Continuity
Connector	Terminal	Connector	Terminal	
B552	5	B213	1	Existed

3. Check continuity between passenger seat control unit harness connector and ground.

Passenger seat control unit		Ground	Continuity
Connector	Terminal		
B552	5		Not existed

Is the inspection result normal?

YES >> GO TO 3.

NO >> Repair or replace harness.

3. CHECK SEAT BELT BUCKLE SWITCH (PASSENGER SIDE) GROUND CIRCUIT

Check continuity between seat belt buckle switch (passenger side) harness connector and ground.

Seat belt buckle switch (passenger side)		Ground	Continuity
Connector	Terminal		
B213	2		Existed

Is the inspection result normal?

YES >> GO TO 4.

NO >> Repair or replace harness.

4. CHECK SEAT BELT BUCKLE SWITCH (PASSENGER SIDE)

Check seat belt buckle switch.

Refer to [SE-76, "PASSENGER SIDE : Component Inspection"](#).

Is the inspection result normal?

YES >> GO TO 5.

NO >> Replace seat belt buckle switch (passenger side). Refer to [SE-199, "Exploded View"](#).

5. CHECK PASSENGER SEAT CONTROL UNIT OUTPUT SIGNAL

1. Connect passenger seat control unit connector.
2. Check voltage between passenger seat control unit harness connector and ground.

SEAT BELT BUCKLE SWITCH

< DTC/CIRCUIT DIAGNOSIS >

(+)		(-)	Condition	Voltage (V) (Approx.)
Passenger seat control unit				
Connector	Terminal			
B552	5	Ground	Not in the sleep mode	5

Is the inspection result normal?

YES >> GO TO 6.

NO >> Replace passenger seat control unit. Refer to [SE-225, "Removal and Installation"](#).

6.CHECK INTERMITTENT INCIDENT

Check intermittent incident.

Refer to [GI-42, "Intermittent Incident"](#).

>> INSPECTION END

PASSENGER SIDE : Component Inspection

INFOID:000000008158046

1.CHECK SEAT BELT BUCKLE SWITCH (PASSENGER SIDE)

1. Turn ignition switch OFF.
2. Disconnect seat belt buckle switch (passenger side) connector.
3. Check continuity between seat belt buckle switch (passenger side) terminals.

Seat belt buckle switch (passenger side)		Condition	Continuity	
Terminal				
1	2	Passenger side seat belt	Fastened	Not existed
			Released	Existed

Is the inspection result normal?

YES >> INSPECTION END

NO >> Replace seat belt buckle switch (passenger side). Refer to [SE-199, "Exploded View"](#).

SLIDING LIMIT SWITCH

< DTC/CIRCUIT DIAGNOSIS >

SLIDING LIMIT SWITCH

DRIVER SIDE

DRIVER SIDE : Description

INFOID:000000008158047

- Sliding limit switch is installed on seat cushion frame.
- Sliding limit switch detects condition of seat sliding.

DRIVER SIDE : Component Function Check

INFOID:000000008158048

1. CHECK FUNCTION

1. Turn ignition switch ON.
2. Select "FWD LIMIT SW" in the "Data Monitor" mode using CONSULT.
3. Check the sliding limit switch signal under the following condition.

Test item	Condition		Status
FWD LIMIT SW	Seat sliding	Front edge	ON
		Other than above	OFF

Is the indication normal?

- YES >> Sliding limit switch function is OK.
 NO >> Refer to [SE-77, "DRIVER SIDE : Diagnosis Procedure"](#).

DRIVER SIDE : Diagnosis Procedure

INFOID:000000008158049

1. CHECK SLIDING LIMIT SWITCH INPUT SIGNAL

1. Turn ignition switch OFF.
2. Disconnect sliding limit switch connector.
3. Check voltage between sliding limit switch harness connector and ground.

(+)		(-)	Condition	Voltage (V) (Approx.)
Sliding limit switch				
Connector	Terminal			
B514	4	Ground	Not in the sleep mode	5

Is the inspection result normal?

- YES >> GO TO 3.
 NO >> GO TO 2.

2. CHECK SLIDING LIMIT SWITCH CIRCUIT

1. Disconnect driver seat control unit connector.
2. Check continuity between driver seat control unit harness connector and sliding limit switch harness connector.

Driver seat control unit		Sliding limit switch		Continuity
Connector	Terminal	Connector	Terminal	
B503	4	B514	4	Existed

3. Check continuity between driver seat control unit harness connector and ground.

Driver seat control unit		Ground	Continuity
Connector	Terminal		
B503	4		Not existed

Is the inspection result normal?

- YES >> Replace driver seat control unit. Refer to [SE-224, "Removal and Installation"](#).
 NO >> Repair or replace harness.

SLIDING LIMIT SWITCH

< DTC/CIRCUIT DIAGNOSIS >

3.CHECK SLIDING LIMIT SWITCH GROUND CIRCUIT

Check continuity between sliding limit switch harness connector and ground.

Sliding limit switch		Ground	Continuity
Connector	Terminal		
B514	32		Existed

Is the inspection result normal?

- YES >> GO TO 4.
- NO >> Repair or replace harness.

4.CHECK SLIDING LIMIT SWITCH

Check sliding limit switch.

Refer to [SE-78, "DRIVER SIDE : Component Inspection"](#).

Is the inspection result normal?

- YES >> GO TO 5.
- NO >> Replace sliding limit switch. Refer to [SE-199, "Exploded View"](#).

5.CHECK INTERMITTENT INCIDENT

Check intermittent incident.

Refer to [GI-42, "Intermittent Incident"](#).

>> INSPECTION END

DRIVER SIDE : Component Inspection

INFOID:000000008158050

1.CHECK SLIDING LIMIT SWITCH

1. Turn ignition switch OFF.
2. Disconnect sliding limit switch connector.
3. Check continuity between sliding limit switch terminals.

Sliding limit switch		Condition	Continuity
Terminal			
4	32	Seat sliding	Front edge Not existed
			Other than above Existed

Is the inspection result normal?

- YES >> INSPECTION END
- NO >> Replace sliding limit switch. Refer to [SE-199, "Exploded View"](#).

PASSENGER SIDE

PASSENGER SIDE : Description

INFOID:000000008158051

- Sliding limit switch is installed on seat cushion frame.
- Sliding limit switch detects condition of seat sliding.

PASSENGER SIDE : Component Function Check

INFOID:000000008158052

1.CHECK FUNCTION

Check whether or not power walk-in function activates normally when power walk-in switch is pressed.

Is the inspection result normal?

- YES >> Sliding limit switch function is OK.
- NO >> Refer to [SE-79, "PASSENGER SIDE : Diagnosis Procedure"](#).

SLIDING LIMIT SWITCH

< DTC/CIRCUIT DIAGNOSIS >

PASSENGER SIDE : Diagnosis Procedure

INFOID:000000008158053

1. CHECK SLIDING LIMIT SWITCH SIGNAL

1. Turn ignition switch OFF.
2. Check voltage between passenger seat control unit harness connector and ground.

(+)		(-)	Condition	Voltage (V) (Approx.)
Passenger seat control unit				
Connector	Terminal			
B552	4	Ground	Sliding position is front edge and not in the sleep mode	5
			Other than above	0

Is the inspection result normal?

YES >> Sliding switch circuit is OK.

NO >> GO TO 2.

2. CHECK SLIDING LIMIT SWITCH CIRCUIT

1. Disconnect passenger seat control unit connector and sliding limit switch connector.
2. Check continuity between passenger seat control unit harness connector and sliding limit switch harness connector.

Passenger seat control unit		Sliding limit switch		Continuity
Connector	Terminal	Connector	Terminal	
B552	4	B558	4	Existed

3. Check continuity between passenger seat control unit harness connector and ground.

Passenger seat control unit		Ground	Continuity
Connector	Terminal		
B552	4		Not existed

Is the inspection result normal?

YES >> GO TO 3.

NO >> Repair or replace harness.

3. CHECK SLIDING LIMIT SWITCH GROUND CIRCUIT

Check continuity between sliding limit switch harness connector and ground.

Sliding limit switch		Ground	Continuity
Connector	Terminal		
B558	32		Existed

Is the inspection result normal?

YES >> GO TO 4.

NO >> Repair or replace harness.

4. CHECK SLIDING LIMIT SWITCH

Check sliding limit switch.

Refer to [SE-80. "PASSENGER SIDE : Component Inspection"](#).

Is the inspection result normal?

YES >> GO TO 5.

NO >> Replace sliding limit switch. Refer to [SE-199. "Exploded View"](#).

5. CHECK PASSENGER SEAT CONTROL UNIT OUTPUT SIGNAL

1. Connect passenger seat control unit connector.
2. Check voltage between passenger seat control unit harness connector and ground.

SLIDING LIMIT SWITCH

< DTC/CIRCUIT DIAGNOSIS >

(+)		(-)	Condition	Voltage (V) (Approx.)
Passenger seat control unit				
Connector	Terminal			
B552	4	Ground	Not in the sleep mode	5

Is the inspection result normal?

YES >> GO TO 6.

NO >> Replace passenger seat control unit. Refer to [SE-225, "Removal and Installation"](#).

6.CHECK INTERMITTENT INCIDENT

Check intermittent incident.

Refer to [GI-42, "Intermittent Incident"](#).

>> INSPECTION END

PASSENGER SIDE : Component Inspection

INFOID:000000008158054

1.CHECK SLIDING LIMIT SWITCH

1. Turn ignition switch OFF.
2. Disconnect sliding limit switch connector.
3. Check continuity between sliding limit switch terminals.

Sliding limit switch		Condition	Continuity
Terminal			
4	32	Seat sliding	Front edge Not existed
			Other than above Existed

Is the inspection result normal?

YES >> INSPECTION END

NO >> Replace sliding limit switch. Refer to [SE-199, "Exploded View"](#).

POWER WALK-IN SWITCH

< DTC/CIRCUIT DIAGNOSIS >

POWER WALK-IN SWITCH DRIVER SIDE

DRIVER SIDE : Description

INFOID:000000008158055

- Power walk-in switch is installed on seatback.
- The operation signal is input to driver seat control unit when power walk-in switch is operated.

DRIVER SIDE : Component Function Check

INFOID:000000008158056

1. CHECK FUNCTION

1. Turn ignition switch ON.
2. Select "WALK-IN SW" in the "Data Monitor" mode using CONSULT.
3. Check the power walk-in switch signal under the following condition.

Test item	Condition		Status
WALK-IN SW	Power walk-in switch	Pressed	ON
		Released	OFF

Is the indication normal?

YES >> Power walk-in switch function is OK.

NO >> Refer to [SE-81, "DRIVER SIDE : Diagnosis Procedure"](#).

DRIVER SIDE : Diagnosis Procedure

INFOID:000000008158057

1. CHECK POWER WALK-IN SWITCH SIGNAL

1. Turn ignition switch OFF.
2. Disconnect power walk-in switch connector.
3. Check voltage between power walk-in switch harness connector and ground.

(+) Power walk-in switch		(-)	Voltage (V) (Approx.)
Connector	Terminal		
B513	30	Ground	Battery voltage

Is the inspection result normal?

YES >> GO TO 3.

NO >> GO TO 2.

2. CHECK POWER WALK-IN SWITCH CIRCUIT

1. Disconnect driver seat control unit connector.
2. Check continuity between driver seat control unit harness connector and power walk-in switch harness connector.

Driver seat control unit		Power walk-in switch		Continuity
Connector	Terminal	Connector	Terminal	
B503	30	B513	30	Existed

3. Check continuity between driver seat control unit harness connector and ground.

Driver seat control unit		Ground	Continuity
Connector	Terminal		
B503	30		Not existed

Is the inspection result normal?

YES >> Replace driver seat control unit. Refer to [SE-224, "Removal and Installation"](#).

NO >> Repair or replace harness.

POWER WALK-IN SWITCH

< DTC/CIRCUIT DIAGNOSIS >

3. CHECK POWER WALK-IN SWITCH GROUND CIRCUIT

Check continuity between power walk-in switch harness connector and ground.

Power walk-in switch		Ground	Continuity
Connector	Terminal		
B513	32		Existed

Is the inspection result normal?

YES >> GO TO 4.

NO >> Repair or replace harness.

4. CHECK POWER WALK-IN SWITCH

Check power walk-in switch.

Refer to [SE-82, "DRIVER SIDE : Component Inspection"](#).

Is the inspection result normal?

YES >> GO TO 5.

NO >> Replace power walk-in switch. Refer to [SE-199, "Exploded View"](#).

5. CHECK INTERMITTENT INCIDENT

Check intermittent incident.

Refer to [GI-42, "Intermittent Incident"](#).

>> INSPECTION END

DRIVER SIDE : Component Inspection

INFOID:000000008158058

1. CHECK POWER WALK-IN SWITCH

1. Turn ignition switch OFF.
2. Disconnect power walk-in switch connector.
3. Check continuity between power walk-in switch terminals.

Power walk-in switch		Condition	Continuity	
Terminal				
30	32	Power walk-in switch	Pressed	Existed
			Released	Not existed

Is the inspection result normal?

YES >> INSPECTION END

NO >> Replace power walk-in switch. Refer to [SE-199, "Exploded View"](#).

PASSENGER SIDE

PASSENGER SIDE : Description

INFOID:000000008158059

- Power walk-in switch is installed on seatback.
- The operation signal is input to passenger seat control unit when power walk-in switch is operated.

PASSENGER SIDE : Component Function Check

INFOID:000000008158060

1. CHECK FUNCTION

Check whether or not power walk-in function activates normally when power walk-in switch is pressed.

Is the indication normal?

YES >> Power walk-in switch function is OK.

NO >> Refer to [SE-83, "PASSENGER SIDE : Diagnosis Procedure"](#).

POWER WALK-IN SWITCH

< DTC/CIRCUIT DIAGNOSIS >

PASSENGER SIDE : Diagnosis Procedure

INFOID:000000008158061

1. CHECK POWER WALK-IN SWITCH SIGNAL

1. Turn ignition switch OFF.
2. Check voltage between passenger seat control unit harness connector and ground.

(+)		(-)	Condition	Voltage (V) (Approx.)	
Passenger seat control unit					
Connector	Terminal				
B552	30	Ground	Power walk-in switch	Pressed	0
				Released	Battery voltage

Is the inspection result normal?

- YES >> Power walk-in switch circuit is OK.
NO >> GO TO 2.

2. CHECK POWER WALK-IN SWITCH CIRCUIT

1. Disconnect passenger seat control unit connector and power walk-in switch connector.
2. Check continuity between passenger seat control unit harness connector and power walk-in switch harness connector.

Passenger seat control unit		Power walk-in switch		Continuity
Connector	Terminal	Connector	Terminal	
B552	30	B557	30	Existed

3. Check continuity between passenger seat control unit harness connector and ground.

Passenger seat control unit		Ground	Continuity
Connector	Terminal		
B552	30		Not existed

Is the inspection result normal?

- YES >> GO TO 3.
NO >> Repair or replace harness.

3. CHECK POWER WALK-IN SWITCH GROUND CIRCUIT

Check continuity between power walk-in switch harness connector and ground.

Power walk-in switch		Ground	Continuity
Connector	Terminal		
B557	32		Existed

Is the inspection result normal?

- YES >> GO TO 4.
NO >> Repair or replace harness.

4. CHECK POWER WALK-IN SWITCH

Check power walk-in switch.

Refer to [SE-84, "PASSENGER SIDE : Component Inspection"](#).

Is the inspection result normal?

- YES >> GO TO 5.
NO >> Replace power walk-in switch. Refer to [SE-199, "Exploded View"](#).

5. CHECK PASSENGER SEAT CONTROL UNIT OUTPUT

1. Connect passenger seat control unit connector.
2. Check voltage between passenger seat control unit harness connector and ground.

POWER WALK-IN SWITCH

< DTC/CIRCUIT DIAGNOSIS >

(+)		(-)	Voltage (V) (Approx.)
Passenger seat control unit			
Connector	Terminal	Ground	Battery voltage
B552	30		

Is the inspection result normal?

YES >> GO TO 6.

NO >> Replace passenger seat control unit. Refer to [SE-225, "Removal and Installation"](#).

6.CHECK INTERMITTENT INCIDENT

Check intermittent incident.

Refer to [GI-42, "Intermittent Incident"](#).

>> INSPECTION END

PASSENGER SIDE : Component Inspection

INFOID:000000008158062

1.CHECK POWER WALK-IN SWITCH

1. Turn ignition switch OFF.
2. Disconnect power walk-in switch connector.
3. Check continuity between power walk-in switch terminals.

Power walk-in switch		Condition	Continuity
Terminal			
30	32	Power walk-in switch Pressed	Existed
		Released	Not existed

Is the inspection result normal?

YES >> INSPECTION END

NO >> Replace power walk-in switch. Refer to [SE-199, "Exploded View"](#).

DOOR SWITCH

< DTC/CIRCUIT DIAGNOSIS >

DOOR SWITCH

Description

INFOID:000000008158063

Detects passenger side doors open or closed condition.

Component Function Check

INFOID:000000008158064

1. CHECK FUNCTION

Check that passenger side power walk-in function operates.

Is the inspection result normal?

- YES >> Door switch function is OK.
- NO >> Refer to [SE-85, "Diagnosis Procedure"](#).

Diagnosis Procedure

INFOID:000000008158065

1. CHECK PASSENGER SIDE DOOR SWITCH

Check passenger side door switch.
Refer to [SE-85, "Component Function Check"](#).

Is the inspection result normal?

- YES >> GO TO 2.
- NO >> Repair or replace the malfunctioning parts.

2. CHECK PASSENGER SIDE DOOR SWITCH INPUT SIGNAL

1. Turn ignition switch OFF.
2. Check signal between passenger seat control unit harness connector and ground with oscilloscope.

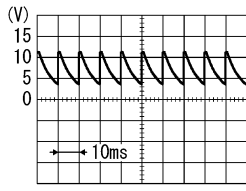
(+)		(-)	Condition	Signal (Reference value)
Passenger seat control unit Connector	Terminal			
B552	8	Ground	Passenger side door switch	<div style="display: flex; justify-content: space-between;"> <div style="text-align: center;"> <p>Pressed</p>  </div> <div style="text-align: center;"> <p>Released</p> <p>0 V</p> </div> </div>

Is the inspection result normal?

- YES >> Passenger side door switch circuit is OK.
- NO >> GO TO 3.

3. CHECK PASSENGER SIDE DOOR SWITCH CIRCUIT

1. Disconnect BCM connector, passenger seat control unit connector and passenger side door switch connector.
2. Check continuity between passenger side door switch harness connector and passenger seat control unit harness connector.

Passenger side door switch		Passenger seat control unit		Continuity
Connector	Terminal	Connector	Terminal	
B216	2	B552	8	Existed

3. Check continuity between passenger side door switch harness connector and ground.

DOOR SWITCH

< DTC/CIRCUIT DIAGNOSIS >

Passenger side door switch		Ground	Continuity
Connector	Terminal		
B216	3		Not existed

Is the inspection result normal?

YES >> GO TO 4.

NO >> Repair or replace harness.

4. CHECK INTERMITTENT INCIDENT

Check intermittent incident.

Refer to [GI-42, "Intermittent Incident"](#).

>> INSPECTION END

SLIDING SENSOR

< DTC/CIRCUIT DIAGNOSIS >

SLIDING SENSOR DRIVER SIDE

DRIVER SIDE : Description

INFOID:000000008158066

- The sliding sensor is installed on the seat slide cushion frame.
- The pulse signal is transmitted to the driver seat control unit when sliding is operated.
- The driver seat control unit counts the pulse and calculates the sliding amount of the seat.

DRIVER SIDE : Component Function Check

INFOID:000000008158067

1.CHECK FUNCTION

1. Turn ignition switch ON.
2. Select "SLIDE PULSE" in the "Data Monitor" mode using CONSULT.
3. Check sliding sensor signal under the following conditions.

Test item	Condition		Status
SLIDE PULSE	Seat sliding	Operate (forward)	Change (increase)*1
		Operate (backward)	Change (decrease)*1
		Release	No change*1

*1: The value at the seat position attained when the battery is connected is considered to be 32768.

Is the indication normal?

- YES >> Sliding sensor function is OK.
 NO >> Refer to [SE-87, "DRIVER SIDE : Diagnosis Procedure"](#).

DRIVER SIDE : Diagnosis Procedure

INFOID:000000008158068

1.CHECK SLIDING SENSOR SIGNAL

1. Turn ignition switch OFF.
2. Check signal between sliding sensor harness connector and ground with oscilloscope.

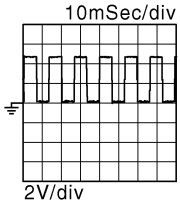
(+)		(-)	Condition	Signal (Reference value)
Sliding sensor				
Connector	Terminal			
B526	24	Ground	Seat sliding	
			Operate	
			Other than above	0 V or 5 V

Is the inspection result normal?

- YES >> GO TO 2.
 NO >> GO TO 3.

2.CHECK SLIDING SENSOR CIRCUIT

1. Disconnect driver seat control unit connector and sliding sensor connector.
2. Check continuity between driver seat control unit harness connector and sliding sensor harness connector.

SLIDING SENSOR

< DTC/CIRCUIT DIAGNOSIS >

Driver seat control unit		Sliding sensor		Continuity
Connector	Terminal	Connector	Terminal	
B503	24	B526	24	Existed

3. Check continuity between driver seat control unit harness connector and ground.

Driver seat control unit		Ground	Continuity
Connector	Terminal		
B503	24		Not existed

Is the inspection result normal?

YES >> Replace driver seat control unit. Refer to [SE-224, "Removal and Installation"](#).

NO >> Repair or replace harness.

3.CHECK SLIDING SENSOR POWER SUPPLY

Check voltage between sliding sensor harness connector and ground.

(+)		(-)	Voltage (V) (Approx.)
Sliding sensor			
Connector	Terminal		
B526	16	Ground	Battery voltage

Is the inspection result normal?

YES >> GO TO 5.

NO >> GO TO 4.

4.CHECK SLIDING SENSOR POWER SUPPLY CIRCUIT

1. Disconnect driver seat control unit connector and sliding sensor connector.
2. Check continuity between driver seat control unit harness connector and sliding sensor harness connector.

Driver seat control unit		Sliding sensor		Continuity
Connector	Terminal	Connector	Terminal	
B503	16	B526	16	Existed

3. Check continuity between driver seat control unit harness connector and ground.

Driver seat control unit		Ground	Continuity
Connector	Terminal		
B503	16		Not existed

Is the inspection result normal?

YES >> Replace driver seat control unit. Refer to [SE-224, "Removal and Installation"](#).

NO >> Repair or replace harness.

5.CHECK SLIDING SENSOR GROUND CIRCUIT

1. Disconnect driver seat control unit connector and sliding sensor connector.
2. Check continuity between driver seat control unit harness connector and sliding sensor harness connector.

Driver seat control unit		Sliding sensor		Continuity
Connector	Terminal	Connector	Terminal	
B503	31	B526	31	Existed

3. Check continuity between driver seat control unit harness connector and ground.

SLIDING SENSOR

< DTC/CIRCUIT DIAGNOSIS >

Driver seat control unit		Ground	Continuity
Connector	Terminal		
B503	31		No existed

Is the inspection result normal?

- YES >> GO TO 6.
 NO >> Repair or replace harness.

6.CHECK SLIDING SENSOR GROUND

1. Connect driver seat control unit connector.
2. Check continuity between driver seat control unit harness connector and ground.

Driver seat control unit		Ground	Continuity
Connector	Terminal		
B503	31		Existed

Is the inspection result normal?

- YES >> Replace sliding sensor. Refer to [SE-199, "Exploded View"](#).
 NO >> Replace driver seat control unit. Refer to [SE-224, "Removal and Installation"](#).

PASSENGER SIDE

PASSENGER SIDE : Description

INFOID:000000008158069

- The sliding sensor is installed on the seat slide cushion frame.
- The pulse signal is transmitted to the passenger seat control unit when sliding is operated.
- The passenger seat control unit counts the pulse and calculates the sliding amount of the seat.

PASSENGER SIDE : Component Function Check

INFOID:000000008158070

1.CHECK FUNCTION

Check whether or not power walk-in function activates normally when power walk-in switch is pressed.

Is the indication normal?

- YES >> Sliding sensor function is OK.
 NO >> Refer to [SE-89, "PASSENGER SIDE : Diagnosis Procedure"](#).

PASSENGER SIDE : Diagnosis Procedure

INFOID:000000008158071

1.CHECK SLIDING SENSOR SIGNAL

1. Turn ignition switch OFF.
2. Check signal between passenger seat control unit harness connector and ground with oscilloscope.

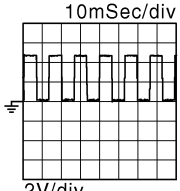
(+)		(-)	Condition	Signal (Reference value)
Passenger seat control unit Connector	Terminal			
B552	24	Ground	Seat sliding	 <p>10mSec/div 2V/div JMJA01192Z</p>
			Other than above	0 V or 5 V

Is the inspection result normal?

- YES >> Sliding sensor function is OK.

SLIDING SENSOR

< DTC/CIRCUIT DIAGNOSIS >

NO >> GO TO 2.

2. CHECK SLIDING SENSOR CIRCUIT

1. Disconnect passenger seat control unit connector and sliding sensor connector.
2. Check continuity between passenger seat control unit harness connector and sliding sensor harness connector.

Passenger seat control unit		Sliding sensor		Continuity
Connector	Terminal	Connector	Terminal	
B552	24	B568	24	Existed

3. Check continuity between passenger seat control unit harness connector and ground.

Passenger seat control unit		Ground	Continuity
Connector	Terminal		
B552	24		Not existed

Is the inspection result normal?

YES >> GO TO 3.

NO >> Repair or replace harness.

3. CHECK SLIDING SENSOR POWER SUPPLY

1. Connect passenger seat control unit connector.
2. Check voltage between sliding sensor harness connector and ground.

(+)		(-)	Voltage (V) (Approx.)
Sliding sensor			
Connector	Terminal		
B568	16	Ground	Battery voltage

Is the inspection result normal?

YES >> GO TO 5.

NO >> GO TO 4.

4. CHECK SLIDING SENSOR POWER SUPPLY CIRCUIT

1. Disconnect passenger seat control unit connector.
2. Check continuity between passenger seat control unit harness connector and sliding sensor harness connector.

Passenger seat control unit		Sliding sensor		Continuity
Connector	Terminal	Connector	Terminal	
B552	16	B568	16	Existed

3. Check continuity between passenger seat control unit harness connector and ground.

Passenger seat control unit		Ground	Continuity
Connector	Terminal		
B552	16		Not existed

Is the inspection result normal?

YES >> Replace passenger seat control unit. Refer to [SE-225. "Removal and Installation"](#).

NO >> Repair or replace harness.

5. CHECK SLIDING SENSOR GROUND CIRCUIT

1. Disconnect passenger seat control unit connector.
2. Check continuity between passenger seat control unit harness connector and sliding sensor harness connector.

SLIDING SENSOR

< DTC/CIRCUIT DIAGNOSIS >

Passenger seat control unit		Sliding sensor		Continuity
Connector	Terminal	Connector	Terminal	
B552	31	B568	31	Existed

3. Check continuity between passenger seat control unit harness connector and ground.

Passenger seat control unit		Ground	Continuity
Connector	Terminal		
B552	31		Not existed

Is the inspection result normal?

YES >> GO TO 6.

NO >> Repair or replace harness.

6. CHECK SLIDING SENSOR GROUND

1. Connect passenger seat control unit connector.
2. Check continuity between passenger seat control unit harness connector and ground.

Passenger seat control unit		Ground	Continuity
Connector	Terminal		
B552	31		Existed

Is the inspection result normal?

YES >> Replace sliding sensor. Refer to [SE-199, "Exploded View"](#).

NO >> Replace passenger seat control unit. Refer to [SE-225, "Removal and Installation"](#).

A
B
C
D
E
F
G
H
I
K
L
M
N
O
P

SE

SLIDING MOTOR

< DTC/CIRCUIT DIAGNOSIS >

SLIDING MOTOR

DRIVER SIDE

DRIVER SIDE : Description

INFOID:000000008158072

- The seat sliding motor is installed to the seat cushion frame.
- The seat sliding motor is activated with the driver seat control unit.
- The seat is slid forward/backward by changing the rotation direction of sliding motor.

DRIVER SIDE : Component Function Check

INFOID:000000008158073

1.CHECK FUNCTION

1. Turn ignition switch ON.
2. Select "SEAT SLIDE" in the "Active Test" mode using CONSULT.
3. Check sliding motor operation.

Test item		Description	
SEAT SLIDE	OFF	Seat sliding	Stop
	FR		Forward
	RR		Backward

Is the operation of relevant parts normal?

- YES >> Sliding motor function is OK.
 NO >> Refer to [SE-92, "DRIVER SIDE : Diagnosis Procedure"](#).

DRIVER SIDE : Diagnosis Procedure

INFOID:000000008158074

1.CHECK SLIDING MOTOR POWER SUPPLY

1. Turn ignition switch OFF.
2. Disconnect sliding motor connector.
3. Check voltage between sliding motor harness connector and ground.

(+)		(-)	Condition	Voltage (V) (Approx.)			
Sliding motor							
Connector	Terminal	Ground	Slide switch	Forward			
B525	35			Ground	Slide switch	Battery voltage	
	42					Other than above	0
						Backward	Battery voltage
	Other than above	0					

Is the inspection result normal?

- YES >> Replace sliding motor.
 NO >> GO TO 2.

2.CHECK SLIDING MOTOR CIRCUIT

1. Disconnect driver seat control unit connector.
2. Check continuity between sliding motor harness connector and driver seat control unit harness connector.

Sliding motor		Driver seat control unit		Continuity
Connector	Terminal	Connector	Terminal	
B525	35	B504	35	Existed
	42		42	

3. Check continuity between driver seat control unit harness connector and ground.

SLIDING MOTOR

< DTC/CIRCUIT DIAGNOSIS >

Driver seat control unit		Ground	Continuity
Connector	Terminal		
B504	35		Not existed
	42		

Is the inspection result normal?

YES >> Replace driver seat control unit. Refer to [SE-224, "Removal and Installation"](#).

NO >> Repair or replace harness.

PASSENGER SIDE

PASSENGER SIDE : Description

INFOID:000000008158075

- The seat sliding motor is installed to the seat cushion frame.
- The seat sliding motor is activated with the passenger seat control unit.
- The seat is slid forward/backward by changing the rotation direction of sliding motor.

PASSENGER SIDE : Component Function Check

INFOID:000000008158076

1.CHECK SLIDING MOTOR CIRCUIT

Check sliding operation with power seat switch.

Is the inspection result normal?

YES >> Sliding motor function is OK.

NO >> Refer to [SE-93, "PASSENGER SIDE : Diagnosis Procedure"](#).

PASSENGER SIDE : Diagnosis Procedure

INFOID:000000008158077

1.CHECK SLIDING MOTOR POWER SUPPLY

1. Turn ignition switch OFF.
2. Disconnect sliding motor connector.
3. Check voltage between sliding motor harness connector and ground.

(+)		(-)	Condition	Voltage (V) (Approx.)	
Sliding motor					
Connector	Terminal				
B567	35	Ground	Slide switch	Forward	Battery voltage
			Other than above	0	
	42		Slide switch	Backward	Battery voltage
			Other than above	0	

Is the inspection result normal?

YES >> Replace sliding motor.

NO >> GO TO 2.

2.CHECK SLIDING MOTOR CIRCUIT

1. Disconnect passenger seat control unit connector.
2. Check continuity between sliding motor harness connector and passenger seat control unit harness connector.

Sliding motor		Passenger seat control unit		Continuity
Connector	Terminal	Connector	Terminal	
B567	35	B553	35	Existed
	42		42	

3. Check continuity between passenger seat control unit harness connector and ground.

SLIDING MOTOR

< DTC/CIRCUIT DIAGNOSIS >

Passenger seat control unit		Ground	Continuity
Connector	Terminal		
B553	35		Not existed
	42		

Is the inspection result normal?

- YES >> Replace passenger seat control unit. Refer to [SE-225. "Removal and Installation"](#).
NO >> Repair or replace harness.

RECLINING MOTOR

< DTC/CIRCUIT DIAGNOSIS >

RECLINING MOTOR

DRIVER SIDE

DRIVER SIDE : Description

INFOID:000000008158078

- The seat reclining motor is installed to the seatback frame.
- The seat reclining motor is activated with the driver seat control unit.
- The seatback is reclined forward/backward by changing the rotation direction of reclining motor.

DRIVER SIDE : Component Function Check

INFOID:000000008158079

1.CHECK RECLINING MOTOR FUNCTION

Check reclining operation with power seat switch.

Is the inspection result normal?

- YES >> Reclining motor function is OK.
 NO >> Refer to [SE-95, "DRIVER SIDE : Diagnosis Procedure"](#).

DRIVER SIDE : Diagnosis Procedure

INFOID:000000008158080

1.CHECK RECLINING MOTOR POWER SUPPLY

1. Turn ignition switch OFF.
2. Disconnect reclining motor connector.
3. Check voltage between reclining motor harness connector and ground.

(+)		(-)	Condition	Voltage (V) (Approx.)	
Reclining motor					
Connector	Terminal				
B524	36	Ground	Reclining switch	Forward	Battery voltage
				Other than above	0
	44			Backward	Battery voltage
				Other than above	0

Is the inspection result normal?

- YES >> Replace reclining motor.
 NO >> GO TO 2.

2.CHECK RECLINING MOTOR CIRCUIT

1. Disconnect driver seat control unit connector.
2. Check continuity between reclining motor harness connector and driver seat control unit harness connector.

Reclining motor		Driver seat control unit		Continuity
Connector	Terminal	Connector	Terminal	
B524	36	B504	36	Existed
	44		44	

3. Check continuity between reclining motor harness connector and ground.

Reclining motor		Ground	Continuity
Connector	Terminal		
B524	36		Not existed
	44		

Is the inspection result normal?

- YES >> Replace driver seat control unit. Refer to [SE-224, "Removal and Installation"](#).
 NO >> Repair or replace harness.

RECLINING MOTOR

< DTC/CIRCUIT DIAGNOSIS >

PASSENGER SIDE

PASSENGER SIDE : Description

INFOID:000000008158081

- The seat reclining motor is installed to the seatback frame.
- The seat reclining motor is activated with the passenger seat control unit.
- The seatback is reclined forward/backward by changing the rotation direction of reclining motor.

PASSENGER SIDE : Component Function Check

INFOID:000000008158082

1.CHECK RECLINING MOTOR FUNCTION

Check reclining operation with power seat switch.

Is the inspection result normal?

- YES >> Reclining motor function is OK.
 NO >> Refer to [SE-96. "PASSENGER SIDE : Diagnosis Procedure"](#).

PASSENGER SIDE : Diagnosis Procedure

INFOID:000000008158083

1.CHECK RECLINING MOTOR POWER SUPPLY

1. Turn ignition switch OFF.
2. Disconnect reclining motor connector.
3. Check voltage between reclining motor harness connector and ground.

(+)		(-)	Condition	Voltage (V) (Approx.)	
Reclining motor					
Connector	Terminal				
B566	36	Ground	Reclining switch	Forward	Battery voltage
				Other than above	0
	44			Backward	Battery voltage
				Other than above	0

Is the inspection result normal?

- YES >> Replace reclining motor.
 NO >> GO TO 2.

2.CHECK RECLINING MOTOR CIRCUIT

1. Disconnect passenger seat control unit connector.
2. Check continuity between reclining motor harness connector and passenger seat control unit harness connector.

Reclining motor		Passenger seat control unit		Continuity
Connector	Terminal	Connector	Terminal	
B566	36	B553	36	Existed
	44		44	

3. Check continuity between reclining motor harness connector and ground.

Reclining motor		Ground	Continuity
Connector	Terminal		
B566	36		Not existed
	44		

Is the inspection result normal?

- YES >> Replace passenger seat control unit. Refer to [SE-225. "Removal and Installation"](#).
 NO >> Repair or replace harness.

LIFTING MOTOR (FRONT)

< DTC/CIRCUIT DIAGNOSIS >

LIFTING MOTOR (FRONT)

DRIVER SIDE

DRIVER SIDE : Description

INFOID:000000008158084

- The lifting motor (front) is installed to the seat slide cushion frame.
- The lifting motor (front) is activated with the driver seat control unit.
- The lifter (front) is moved upward/downward by changing the rotation direction of lifting motor (front).

DRIVER SIDE : Component Function Check

INFOID:000000008158085

1.CHECK LIFTING MOTOR (FRONT) FUNCTION

Check lifting operation with power seat switch.

Is the inspection result normal?

- YES >> Lifting motor (front) function is OK.
 NO >> Refer to [SE-97, "DRIVER SIDE : Diagnosis Procedure"](#).

DRIVER SIDE : Diagnosis Procedure

INFOID:000000008158086

1.CHECK LIFTING MOTOR (FRONT) POWER SUPPLY

1. Turn ignition switch OFF.
2. Disconnect lifting motor (front) connector.
3. Check voltage between lifting motor (front) harness connector and ground.

(+)		(-)	Condition	Voltage (V) (Approx.)
Lifting motor (front)				
Connector	Terminal			
B528	37	Ground	Downward	Battery voltage
			Other than above	0
	45		Upward	Battery voltage
			Other than above	0

Is the inspection result normal?

- YES >> Replace lifting motor (front).
 NO >> GO TO 2.

2.CHECK LIFTING MOTOR (FRONT) CIRCUIT

1. Disconnect driver seat control unit connector.
2. Check continuity between lifting motor (front) harness connector and driver seat control unit harness connector.

Lifting motor (front)		Driver seat control unit		Continuity
Connector	Terminal	Connector	Terminal	
B528	37	B504	37	Existed
	45		45	

3. Check continuity between lifting motor (front) harness connector and ground.

Lifting motor (front)		Ground	Continuity
Connector	Terminal		
B528	37		Not existed
	45		

Is the inspection result normal?

- YES >> Replace driver seat control unit. Refer to [SE-224, "Removal and Installation"](#).
 NO >> Repair or replace harness.

LIFTING MOTOR (FRONT)

< DTC/CIRCUIT DIAGNOSIS >

PASSENGER SIDE

PASSENGER SIDE : Description

INFOID:000000008158087

- The lifting motor (front) is installed to the seat slide cushion frame.
- The lifting motor (front) is activated with the passenger seat control unit.
- The lifter (front) is moved upward/downward by changing the rotation direction of lifting motor (front).

PASSENGER SIDE : Component Function Check

INFOID:000000008158088

1.CHECK LIFTING MOTOR (FRONT) FUNCTION

Check lifting operation with power seat switch.

Is the inspection result normal?

YES >> Lifting motor (front) function is OK.

NO >> Refer to [SE-98, "PASSENGER SIDE : Diagnosis Procedure"](#).

PASSENGER SIDE : Diagnosis Procedure

INFOID:000000008158089

1.CHECK LIFTING MOTOR (FRONT) POWER SUPPLY

1. Turn ignition switch OFF.
2. Disconnect lifting motor (front) connector.
3. Check voltage between lifting motor (front) harness connector and ground.

(+)		(-)	Condition	Voltage (V) (Approx.)
Connector	Terminal			
B569	37	Ground	Downward	Battery voltage
			Other than above	0
	45		Upward	Battery voltage
			Other than above	0

Is the inspection result normal?

YES >> Replace lifting motor (front).

NO >> GO TO 2.

2.CHECK LIFTING MOTOR (FRONT) CIRCUIT

1. Disconnect passenger seat control unit connector.
2. Check continuity between lifting motor (front) harness connector and passenger seat control unit harness connector.

Lifting motor (front)		Passenger seat control unit		Continuity
Connector	Terminal	Connector	Terminal	
B569	37	B553	37	Existed
	45		45	

3. Check continuity between lifting motor (front) harness connector and ground.

Lifting motor (front)		Ground	Continuity
Connector	Terminal		
B569	37		Not existed
	45		

Is the inspection result normal?

YES >> Replace passenger seat control unit. Refer to [SE-225, "Removal and Installation"](#).

NO >> Repair or replace harness.

LIFTING MOTOR (REAR)

< DTC/CIRCUIT DIAGNOSIS >

LIFTING MOTOR (REAR) DRIVER SIDE

DRIVER SIDE : Description

INFOID:000000008158090

- The lifting motor (rear) is installed to the seat slide cushion frame.
- The lifting motor (rear) is activated with the driver seat control unit.
- The seat lifter (rear) is moved upward/downward by changing the rotation direction of lifting motor (rear).

DRIVER SIDE : Component Function Check

INFOID:000000008158091

1.CHECK LIFTING MOTOR (REAR) FUNCTION

Check lifting operation with power seat switch.

Is the inspection result normal?

- YES >> Lifting motor (rear) function is OK.
 NO >> Refer to [SE-99, "DRIVER SIDE : Diagnosis Procedure"](#).

DRIVER SIDE : Diagnosis Procedure

INFOID:000000008158092

1.CHECK LIFTING MOTOR (REAR) POWER SUPPLY

1. Turn ignition switch OFF.
2. Disconnect lifting motor (rear) connector.
3. Check voltage between lifting motor (rear) harness connector and ground.

(+)		(-)	Condition	Voltage (V) (Approx.)
Lifting motor (rear)				
Connector	Terminal			
B530	38	Ground	Upward	Battery voltage
			Other than above	0
	39		Downward	Battery voltage
			Other than above	0

Is the inspection result normal?

- YES >> Replace lifting motor (rear).
 NO >> GO TO 2.

2.CHECK LIFTING MOTOR (REAR) CIRCUIT

1. Disconnect driver seat control unit connector.
2. Check continuity between lifting motor (rear) harness connector and driver seat control unit harness connector.

Lifting motor (rear)		Driver seat control unit		Continuity
Connector	Terminal	Connector	Terminal	
B530	38	B504	38	Existed
	39		39	

3. Check continuity between lifting motor (rear) harness connector and ground.

Lifting motor (rear)		Ground	Continuity
Connector	Terminal		
B530	38		Not existed
	39		

Is the inspection result normal?

- YES >> Replace driver seat control unit. Refer to [SE-224, "Removal and Installation"](#).
 NO >> Repair or replace harness.

LIFTING MOTOR (REAR)

< DTC/CIRCUIT DIAGNOSIS >

PASSENGER SIDE

PASSENGER SIDE : Description

INFOID:000000008158093

- The lifting motor (rear) is installed to the seat slide cushion frame.
- The lifting motor (rear) is activated with the passenger seat control unit.
- The seat lifter (rear) is moved upward/downward by changing the rotation direction of lifting motor (rear).

PASSENGER SIDE : Component Function Check

INFOID:000000008158094

1.CHECK LIFTING MOTOR (REAR) FUNCTION

Check lifting operation with power seat switch.

Is the inspection result normal?

YES >> Lifting motor (rear) function is OK.

NO >> Refer to [SE-100, "PASSENGER SIDE : Diagnosis Procedure"](#).

PASSENGER SIDE : Diagnosis Procedure

INFOID:000000008158095

1.CHECK LIFTING MOTOR (REAR) POWER SUPPLY

1. Turn ignition switch OFF.
2. Disconnect lifting motor (rear) connector.
3. Check voltage between lifting motor (rear) harness connector and ground.

(+)		(-)	Condition	Voltage (V) (Approx.)	
Lifting motor (rear)					
Connector	Terminal				
B570	38	Ground	Lifting switch (rear)	Upward	Battery voltage
				Other than above	0
	39			Downward	Battery voltage
				Other than above	0

Is the inspection result normal?

YES >> Replace lifting motor (rear).

NO >> GO TO 2.

2.CHECK LIFTING MOTOR (REAR) CIRCUIT

1. Disconnect passenger seat control unit connector.
2. Check continuity between lifting motor (rear) harness connector and passenger seat control unit harness connector.

Lifting motor (rear)		Passenger seat control unit		Continuity
Connector	Terminal	Connector	Terminal	
B570	38	B553	38	Existed
	39		39	

3. Check continuity between lifting motor (rear) unit harness connector and ground.

Lifting motor (rear)		Ground	Continuity
Connector	Terminal		
B570	38		Not existed
	39		

Is the inspection result normal?

YES >> Replace passenger seat control unit. Refer to [SE-225, "Removal and Installation"](#).

NO >> Repair or replace harness.

HEATED SEAT SWITCH

< DTC/CIRCUIT DIAGNOSIS >

HEATED SEAT SWITCH DRIVER SIDE

DRIVER SIDE : Description

INFOID:000000008158096

Adjusts heated seat temperature and deactivates heated seat.

DRIVER SIDE : Component Function Check

INFOID:000000008158097

1. CHECK FUNCTION

Check that heated seat warms to preset temperature when operating heated seat switch to the optimal position.

Is the inspection result normal?

- YES >> Heated seat switch function is OK.
 NO >> Refer to [SE-101, "DRIVER SIDE : Diagnosis Procedure"](#).

DRIVER SIDE : Diagnosis Procedure

INFOID:000000008158098

1. CHECK HEATED SEAT CONTROL UNIT INPUT SIGNAL

1. Turn ignition switch OFF.
2. Disconnect heated seat control unit connector.
3. Turn ignition switch ON.
4. Check voltage between heated seat control unit harness connector and ground.

(+)		(-)	Condition	Voltage (V) (Approx.)	
Heated seat control unit					
Connector	Terminal				
B518	67	Ground	Heated seat switch position	OFF	0
				1 (Min. temperature)	12.24
				2	12.33
				3	12.49
				4	12.63
				5	12.76
				6 (Max. temperature)	12.90

Is the inspection result normal?

- YES >> Heated seat switch circuit is OK.
 NO >> GO TO 2.

2. CHECK HEATED SEAT SWITCH CIRCUIT

1. Turn ignition switch OFF.
2. Disconnect heated seat switch connector.
3. Check continuity between heated seat switch harness connector and heated seat control unit harness connector.

Heated seat switch		Heated seat control unit		Continuity
Connector	Terminal	Connector	Terminal	
A/T models: M141 M/T models: M175	2	B518	67	Existed

4. Check continuity between heated seat switch harness connector and ground.

HEATED SEAT SWITCH

< DTC/CIRCUIT DIAGNOSIS >

Heated seat switch		Ground	Continuity
Connector	Terminal		
A/T models: M141 M/T models: M175	2		Not existed

Is the inspection result normal?

- YES >> GO TO 3.
NO >> Repair or replace harness.

3.CHECK HEATED SEAT SWITCH

Check heated seat switch.

Refer to [SE-102, "DRIVER SIDE : Component Inspection"](#).

Is the inspection result normal?

- YES >> GO TO 4.
NO >> Replace heated seat switch. Refer to [SE-231, "Removal and Installation"](#).

4.CHECK INTERMITTENT INCIDENT

Check intermittent incident.

Refer to [GI-42, "Intermittent Incident"](#).

>> INSPECTION END

DRIVER SIDE : Component Inspection

INFOID:000000008158099

1.CHECK FRONT HEATED SEAT SWITCH

1. Turn ignition switch OFF.
2. Disconnect heated seat switch connector.
3. Check resistance between heated seat switch terminals.

Heated seat switch		Condition	Resistance (K Ω) (Approx.)	
Connector	Terminal			
A/T models: M141 M/T models: M175	5	1	ON OFF	0 ∞
		2	Heated seat switch position	1 (Min. temperature) 2 3 4 5 6 (Max. temperature)

Is the inspection result normal?

- YES >> INSPECTION END
NO >> Replace heated seat switch. Refer to [SE-231, "Removal and Installation"](#).

PASSENGER SIDE

PASSENGER SIDE : Description

INFOID:000000008158100

Adjusts heated seat temperature and deactivates heated seat.

PASSENGER SIDE : Component Function Check

INFOID:000000008158101

1.CHECK FUNCTION

Check that heated seat warms to preset temperature when operating heated seat switch to the optimal position.

HEATED SEAT SWITCH

< DTC/CIRCUIT DIAGNOSIS >

Is the inspection result normal?

- YES >> Heated seat switch function is OK.
 NO >> Refer to [SE-103, "PASSENGER SIDE : Diagnosis Procedure"](#).

PASSENGER SIDE : Diagnosis Procedure

INFOID:000000008158102

1. CHECK HEATED SEAT CONTROL UNIT INPUT SIGNAL

- Turn ignition switch OFF.
- Disconnect heated seat control unit connector.
- Turn ignition switch ON.
- Check voltage between heated seat control unit harness connector and ground.

(+)		(-)	Condition	Voltage (V) (Approx.)	
Heated seat control unit					
Connector	Terminal				
B575	67	Ground	Heated seat switch position	OFF	0
				1 (Min. temperature)	12.24
				2	12.33
				3	12.49
				4	12.63
				5	12.76
				6 (Max. temperature)	12.90

Is the inspection result normal?

- YES >> Heated seat switch circuit is OK.
 NO >> GO TO 2.

2. CHECK HEATED SEAT SWITCH CIRCUIT

- Turn ignition switch OFF.
- Disconnect heated seat switch connector.
- Check continuity between heated seat switch harness connector and heated seat control unit harness connector.

Heated seat switch		Heated seat control unit		Continuity
Connector	Terminal	Connector	Terminal	
A/T models: M142 M/T models: M176	2	B575	67	Existed

- Check continuity between heated seat switch harness connector and ground.

Heated seat switch		Ground	Continuity
Connector	Terminal		
A/T models: M142 M/T models: M176	2		Not existed

Is the inspection result normal?

- YES >> GO TO 3.
 NO >> Repair or replace harness.

3. CHECK HEATED SEAT SWITCH

Check heated seat switch.
 Refer to [SE-104, "PASSENGER SIDE : Component Inspection"](#).

Is the inspection result normal?

- YES >> GO TO 4.
 NO >> Replace heated seat switch. Refer to [SE-231, "Removal and Installation"](#).

4. CHECK INTERMITTENT INCIDENT

HEATED SEAT SWITCH

< DTC/CIRCUIT DIAGNOSIS >

Check intermittent incident.
Refer to [GI-42, "Intermittent Incident"](#).

>> INSPECTION END

PASSENGER SIDE : Component Inspection

INFOID:000000008158103

1. CHECK FRONT HEATED SEAT SWITCH

1. Turn ignition switch OFF.
2. Disconnect heated seat switch connector.
3. Check resistance between heated seat switch terminals.

Heated seat switch		Condition	Resistance (K Ω) (Approx.)	
Connector	Terminal			
A/T models: M142 M/T models: M176	5	1	ON OFF	0 ∞
		2	1 (Min. temperature)	2.400
	2		1.800	
	3		1.200	
	4		0.910	
	5		0.620	
	6 (Max. temperature)	0.348		

Is the inspection result normal?

- YES >> INSPECTION END
NO >> Replace heated seat switch. Refer to [SE-231, "Removal and Installation"](#).

HEATED SEAT RELAY

< DTC/CIRCUIT DIAGNOSIS >

HEATED SEAT RELAY

Description

INFOID:000000008158104

Power is supplied to the heated seat using ignition power supply control.

Component Function Check

INFOID:000000008158105

1. CHECK FUNCTION

Check that heated seat warms to preset temperature when operating heated seat switch to the optimal position.

Is the inspection result normal?

- YES >> Heated seat relay function is OK.
- NO >> Refer to [SE-105. "Diagnosis Procedure"](#)

Diagnosis Procedure

INFOID:000000008158106

1. CHECK HEATED SEAT RELAY POWER SUPPLY

1. Turn ignition switch OFF.
2. Disconnect heated seat relay.
3. Turn ignition switch ON.
4. Check voltage between heated seat relay terminal connector and ground.

(+)		(-)	Voltage (V) (Approx.)
Heated seat relay			
Connector	Terminal	Ground	Battery voltage
E19	2		

Is the inspection result normal?

- YES >> GO TO 3.
- NO >> GO TO 2.

2. CHECK HEATED SEAT RELAY POWER SUPPLY CIRCUIT

1. Turn ignition switch OFF.
2. Disconnect fuse block (J/B) connector.
3. Check continuity between heated seat relay terminal connector and fuse block (J/B) harness connector.

Heated seat relay		Fuse block (J/B)		Continuity
Connector	Terminal	Connector	Terminal	
E19	2	M1	2A	Existed

4. Check continuity between heated seat relay terminal connector and ground.

Heated seat relay		Ground	Continuity
Connector	Terminal		
E19	2		Not existed

Is the inspection result normal?

- YES >> GO TO 5.
- NO >> Repair or replace harness.

3. CHECK HEATED SEAT RELAY GROUND CIRCUIT

1. Turn ignition switch OFF.
2. Check continuity between heated seat relay terminal connector and ground.

HEATED SEAT RELAY

< DTC/CIRCUIT DIAGNOSIS >

Heated seat relay		Ground	Continuity
Connector	Terminal		
E19	1		Existed

Is the inspection result normal?

- YES >> GO TO 4.
 NO >> Repair or replace harness.

4.CHECK HEATED SEAT RELAY

Check heated seat relay.

Refer to [SE-106, "Component Inspection"](#).

Is the inspection result normal?

- YES >> Heated seat relay circuit is OK.
 NO >> Replace heated seat relay.

5.CHECK INTERMITTENT INCIDENT

Check intermittent incident.

Refer to [GI-42, "Intermittent Incident"](#)

>> INSPECTION END

Component Inspection

INFOID:000000008158107

1.CHECK HEATED SEAT RELAY

1. Turn ignition switch OFF.
2. Disconnect heated seat relay.
3. Check continuity between heated seat relay terminals.

heated seat relay		Condition	Continuity
Terminal			
3	5	12 V direct current supply between terminals 1 and 2.	Existed
		No current supply	Not existed

Is the inspection result normal?

- YES >> INSPECTION END
 NO >> Replace heated seat relay.

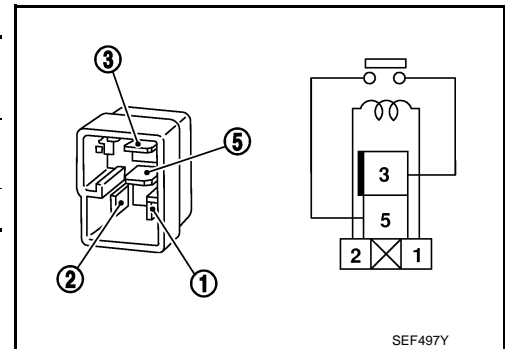

HEAT SENSOR

< DTC/CIRCUIT DIAGNOSIS >

HEAT SENSOR

DRIVER SIDE

DRIVER SIDE : Description

INFOID:000000008158108

Detects seat cushion heater temperature and outputs to heated seat control unit.

DRIVER SIDE : Component Function Check

INFOID:000000008158109

1.CHECK FUNCTION

Check that heated seat warms to preset temperature when operating heated seat switch to the optimal position.

Is the inspection result normal?

YES >> Heat sensor function is OK.

NO >> Refer to [SE-107, "DRIVER SIDE : Diagnosis Procedure"](#)

DRIVER SIDE : Diagnosis Procedure

INFOID:000000008158110

1.CHECK HEAT SENSOR INPUT SIGNAL

1. Turn ignition switch ON.
2. Check voltage between heated seat control unit harness connector and ground.

(+)		(-)	Condition	Voltage (V) (Approx.)	
Heated seat control unit					
Connector	Terminal				
B518	69	Ground	Heated seat switch position	OFF	0
				1 (Min. temperature)	10.87 – 11.02
				2	10.93 – 11.07
				3	11.04 – 11.17
				4	11.13 – 11.26
				5	11.22 – 11.34
			6 (Max. temperature)	11.31 – 11.43	

NOTE:

Voltage is repeated within the value shown as per the following list depending on heater unit temperature.

Is the inspection result normal?

YES >> heat sensor is OK.

NO >> GO TO 2.

2.CHECK HEAT SENSOR CIRCUIT

1. Turn ignition switch OFF.
2. Disconnect heated seat control unit connector and seat cushion heater connector.
3. Check continuity between heated seat control unit harness connector and seat cushion heater harness connector.

Heated seat control unit		Seat cushion heater		Continuity
Connector	Terminal	Connector	Terminal	
B518	69	B517	69	Existed

4. Check continuity between heated seat control unit harness connector and ground.

Heated seat control unit		Ground	Continuity
Connector	Terminal		
B518	69		Not existed

Is the inspection result normal?

HEAT SENSOR

< DTC/CIRCUIT DIAGNOSIS >

- YES >> GO TO 3.
NO >> Repair or replace harness.

3.CHECK HEAT SENSOR POWER SUPPLY

1. Turn ignition switch ON.
2. Turn heated seat switch ON.
3. Check voltage between seat cushion heater harness connector and ground.

(+)		(-)	Voltage (V) (Approx.)
Seat cushion heater			
Connector	Terminal		
B517	66	Ground	Battery voltage

Is the inspection result normal?

- YES >> GO TO 5.
NO >> GO TO 4.

4.CHECK HEAT SENSOR POWER SUPPLY CIRCUIT

1. Turn ignition switch OFF.
2. Disconnect heated seat switch connector.
3. Check continuity between heated seat control unit harness connector and seat cushion heater harness connector.

Heated seat control unit		Seat cushion heater		Continuity
Connector	Terminal	Connector	Terminal	
B518	66	B517	66	Existed

4. Check continuity between heated seat control unit harness connector and ground.

Heated seat control unit		Ground	Continuity
Connector	Terminal		
B518	66		Not existed

Is the inspection result normal?

- YES >> GO TO 6.
NO >> Repair or replace harness.

5.CHECK HEAT SENSOR

Check heat sensor. Refer to [SE-108, "DRIVER SIDE : Component Inspection"](#).

Is the inspection result normal?

- YES >> GO TO 6.
NO >> Replace seat cushion heater. Refer to [SE-210, "Removal and Installation"](#).

6.CHECK INTERMITTENT INCIDENT

Check intermittent incident.
Refer to [GI-42, "Intermittent Incident"](#)

>> INSPECTION END

DRIVER SIDE : Component Inspection

INFOID:000000008158111

1.CHECK HEAT SENSOR

1. Turn ignition switch OFF.
2. Disconnect seat cushion heater connector.
3. Check resistance between seat cushion heater terminals.

HEAT SENSOR

< DTC/CIRCUIT DIAGNOSIS >

Seat cushion heater		Condition	Resistance (KΩ) (Approx.)
Terminal			
66	69	When heat sensor temperature is 25°C (77°F)	9.9 – 10.1

NOTE:

Resistance value changes according to temperature.

Is the inspection result normal?

YES >> INSPECTION END

NO >> Replace seat cushion heater. Refer to [SE-199, "Exploded View"](#).

PASSENGER SIDE

PASSENGER SIDE : Description

INFOID:000000008158112

Detects seat cushion heater temperature and outputs to heated seat control unit.

PASSENGER SIDE : Component Function Check

INFOID:000000008158113

1.CHECK FUNCTION

Check that heated seat warms to preset temperature when operating heated seat switch to the optimal position.

Is the inspection result normal?

YES >> Heat sensor function is OK.

NO >> Refer to [SE-109, "PASSENGER SIDE : Diagnosis Procedure"](#)

PASSENGER SIDE : Diagnosis Procedure

INFOID:000000008158114

1.CHECK HEAT SENSOR INPUT SIGNAL

1. Turn ignition switch ON.
2. Check voltage between heated seat control unit harness connector and ground.

SE

(+)		(-)	Condition	Voltage (V) (Approx.)	
Heated seat control unit					
Connector	Terminal				
B575	69	Ground	Heated seat switch position	OFF	0
				1 (Min. temperature)	10.87 – 11.02
				2	10.93 – 11.07
				3	11.04 – 11.17
				4	11.13 – 11.26
				5	11.22 – 11.34
				6 (Max. temperature)	11.31 – 11.43

NOTE:

Voltage is repeated within the value shown as per the following list depending on heater unit temperature.

Is the inspection result normal?

YES >> heat sensor is OK.

NO >> GO TO 2.

2.CHECK HEAT SENSOR CIRCUIT

1. Turn ignition switch OFF.
2. Disconnect heated seat control unit connector and seat cushion heater connector.
3. Check continuity between heated seat control unit harness connector and seat cushion heater harness connector.

P

HEAT SENSOR

< DTC/CIRCUIT DIAGNOSIS >

Heated seat control unit		Seat cushion heater		Continuity
Connector	Terminal	Connector	Terminal	
B575	69	B574	69	Existed

4. Check continuity between heated seat control unit harness connector and ground.

Heated seat control unit		Ground	Continuity
Connector	Terminal		
B575	69		Not existed

Is the inspection result normal?

YES >> GO TO 3.

NO >> Repair or replace harness.

3.CHECK HEAT SENSOR POWER SUPPLY

1. Turn ignition switch ON.
2. Turn heated seat switch ON.
3. Check voltage between seat cushion heater harness connector and ground.

(+)		(-)	Voltage (V) (Approx.)
Seat cushion heater			
Connector	Terminal		
B574	66	Ground	Battery voltage

Is the inspection result normal?

YES >> GO TO 5.

NO >> GO TO 4.

4.CHECK HEAT SENSOR POWER SUPPLY CIRCUIT

1. Turn ignition switch OFF.
2. Disconnect heated seat switch connector.
3. Check continuity between heated seat control unit harness connector and seat cushion heater harness connector.

Heated seat control unit		Seat cushion heater		Continuity
Connector	Terminal	Connector	Terminal	
B575	66	B574	66	Existed

4. Check continuity between heated seat control unit harness connector and ground.

Heated seat control unit		Ground	Continuity
Connector	Terminal		
B575	66		Not existed

Is the inspection result normal?

YES >> GO TO 6.

NO >> Repair or replace harness.

5.CHECK HEAT SENSOR

Check heat sensor. Refer to [SE-111, "PASSENGER SIDE : Component Inspection"](#).

Is the inspection result normal?

YES >> GO TO 6.

NO >> Replace seat cushion heater. Refer to [SE-199, "Exploded View"](#).

6.CHECK INTERMITTENT INCIDENT

Check intermittent incident.

Refer to [GI-42, "Intermittent Incident"](#)

HEAT SENSOR

< DTC/CIRCUIT DIAGNOSIS >

>> INSPECTION END

PASSENGER SIDE : Component Inspection

INFOID:000000008158115

1. CHECK HEAT SENSOR

1. Turn ignition switch OFF.
2. Disconnect seat cushion heater connector.
3. Check resistance between seat cushion heater terminals.

Seat cushion heater		Condition	Resistance (KΩ) (Approx.)
Terminal			
66	69	When heat sensor temperature is 25°C (77°F)	9.9 – 10.1

NOTE:

Resistance value changes according to temperature.

Is the inspection result normal?

YES >> INSPECTION END

NO >> Replace seat cushion heater. Refer to [SE-199, "Exploded View"](#).

A
B
C
D
E
F
G
H
I
K
L
M
N
O
P

SE

SEAT CUSHION HEATER

< DTC/CIRCUIT DIAGNOSIS >

SEAT CUSHION HEATER DRIVER SIDE

DRIVER SIDE : Description

INFOID:000000008158116

Warms the seat cushion.

DRIVER SIDE : Component Function Check

INFOID:000000008158117

1.CHECK FUNCTION

Check that heated seat warms to preset temperature when operating heated seat switch to the optimal position.

Is the inspection result normal?

YES >> Seat cushion heater function is OK.

NO >> Refer to [SE-112, "DRIVER SIDE : Diagnosis Procedure"](#).

DRIVER SIDE : Diagnosis Procedure

INFOID:000000008158118

1.CHECK SEAT CUSHION HEATER INPUT SIGNAL

1. Turn ignition switch OFF.
2. Disconnect seat cushion heater connector.
3. Turn ignition switch ON.
4. Check voltage between seat cushion heater harness connector and ground.

(+)		(-)	Condition	Voltage (V) (Approx.)	
Seat cushion heater					
Connector	Terminal				
B517	68	Ground	Heated seat	Operates	0 – Battery voltage
				Other than above	0

NOTE:

Voltage is repeated within the value shown as per the following list depending on heater unit temperature.

Is the inspection result normal?

YES >> GO TO 3.

NO >> GO TO 2.

2.CHECK SEAT CUSHION HEATER CIRCUIT

1. Turn ignition switch OFF.
2. Disconnect heated seat control unit connector.
3. Check continuity between seat cushion heater harness connector and heated seat control unit harness connector.

Seat cushion heater		Heated seat control unit		Continuity
Connector	Terminal	Connector	Terminal	
B517	68	B518	68	Existed

4. Check continuity between seat cushion heater harness connector and ground.

Seat cushion heater		Ground	Continuity
Connector	Terminal		
B517	68		Not existed

Is the inspection result normal?

YES >> Replace heated seat control unit. Refer to [SE-226, "Removal and Installation"](#).

NO >> Repair or replace harness.

3.CHECK SEAT CUSHION HEATER

SEAT CUSHION HEATER

< DTC/CIRCUIT DIAGNOSIS >

Check seat cushion heater.

Refer to [SE-113, "DRIVER SIDE : Component Inspection"](#).

Is the inspection result normal?

YES >> GO TO 4.

NO >> Replace seat cushion heater. Refer to [SE-199, "Exploded View"](#).

4.CHECK SEAT CUSHION HEATER GROUND CIRCUIT

Check continuity between seat cushion heater harness connector and ground.

Seat cushion heater		Ground	Continuity
Connector	Terminal		
B517	48		Existed

Is the inspection result normal?

YES >> GO TO 5.

NO >> Repair or replace harness.

5.CHECK INTERMITTENT INCIDENT

Check intermittent incident.

Refer to [GI-42, "Intermittent Incident"](#)

>> INSPECTION END

DRIVER SIDE : Component Inspection

INFOID:000000008158119

1.CHECK SEAT CUSHION HEATER

1. Turn ignition switch OFF.
2. Disconnect seat cushion heater connector and seatback heater connector.
3. Check resistance between seat cushion heater terminals.

Seat cushion heater		Condition	Resistance (Ω) (Approx.)
Terminal			
48	68	When heat sensor temperature is 20°C (68°F)	2.6 – 3.0

NOTE:

Resistance value changes according to temperature.

Is the inspection result normal?

YES >> INSPECTION END

NO >> Replace seat cushion heater. Refer to [SE-199, "Exploded View"](#).

PASSENGER SIDE

PASSENGER SIDE : Description

INFOID:000000008158120

Warms the seat cushion.

PASSENGER SIDE : Component Function Check

INFOID:000000008158121

1.CHECK FUNCTION

Check that heated seat warms to preset temperature when operating heated seat switch to the optimal position.

Is the inspection result normal?

YES >> Seat cushion heater function is OK.

NO >> Refer to [SE-113, "PASSENGER SIDE : Diagnosis Procedure"](#).

PASSENGER SIDE : Diagnosis Procedure

INFOID:000000008158122

1.CHECK FRONT SEAT CUSHION HEATER INPUT SIGNAL

SEAT CUSHION HEATER

< DTC/CIRCUIT DIAGNOSIS >

1. Turn ignition switch OFF.
2. Disconnect seat cushion heater connector.
3. Turn ignition switch ON.
4. Check voltage between seat cushion heater harness connector and ground.

(+)		(-)	Condition	Voltage (V) (Approx.)
Seat cushion heater				
Connector	Terminal			
B574	68	Ground	Heated seat	Operates
				Other than above
				0 – Battery voltage
				0

NOTE:

Voltage is repeated within the value shown as per the following list depending on heater unit temperature.

Is the inspection result normal?

- YES >> GO TO 3.
 NO >> GO TO 2.

2.CHECK SEAT CUSHION HEATER CIRCUIT

1. Turn ignition switch OFF.
2. Disconnect heated seat control unit connector.
3. Check continuity between seat cushion heater harness connector and heated seat control unit harness connector.

Seat cushion heater		Heated seat control unit		Continuity
Connector	Terminal	Connector	Terminal	
B574	68	B575	68	Existed

4. Check continuity between seat cushion heater harness connector and ground.

Seat cushion heater		Ground	Continuity
Connector	Terminal		
B574	68		Not existed

Is the inspection result normal?

- YES >> Replace heated seat control unit. Refer to [SE-226. "Removal and Installation"](#).
 NO >> Repair or replace harness.

3.CHECK SEAT CUSHION HEATER

Check seat cushion heater.

Refer to [SE-115. "PASSENGER SIDE : Component Inspection"](#).

Is the inspection result normal?

- YES >> GO TO 4.
 NO >> Replace seat cushion heater. Refer to [SE-199. "Exploded View"](#).

4.CHECK SEAT CUSHION HEATER GROUND CIRCUIT

1. Turn ignition switch OFF.
2. Check continuity between seat cushion heater harness connector and ground.

Seat cushion heater		Ground	Continuity
Connector	Terminal		
B574	48		Existed

Is the inspection result normal?

- YES >> GO TO 5.
 NO >> Repair or replace harness.

5.CHECK INTERMITTENT INCIDENT

Check intermittent incident.

SEAT CUSHION HEATER

< DTC/CIRCUIT DIAGNOSIS >

Refer to [GI-42. "Intermittent Incident"](#)

>> INSPECTION END

PASSENGER SIDE : Component Inspection

INFOID:000000008158123

1. CHECK SEAT CUSHION HEATER

1. Turn ignition switch OFF.
2. Disconnect seat cushion heater connector and seatback heater connector.
3. Check resistance between seat cushion heater terminals.

Seat cushion heater		Condition	Resistance (Ω) (Approx.)
Terminal			
48	68	When heat sensor temperature is 20°C (68°F)	2.6 – 3.0

NOTE:

Resistance value changes according to temperature.

Is the inspection result normal?

YES >> INSPECTION END

NO >> Replace seat cushion heater. Refer to [SE-199. "Exploded View"](#).

A
B
C
D
E
F
G
H
I
K
L
M
N
O
P

SE

SEATBACK HEATER

< DTC/CIRCUIT DIAGNOSIS >

SEATBACK HEATER DRIVER SIDE

DRIVER SIDE : Description

INFOID:000000008158124

Warms the seat cushion.

DRIVER SIDE : Component Function Check

INFOID:000000008158125

1.CHECK FUNCTION

Check that heated seat warms to preset temperature when operating heated seat switch to the optimal position.

Is the inspection result normal?

- YES >> Seatback heater function is OK.
NO >> Refer to [SE-116, "DRIVER SIDE : Diagnosis Procedure"](#).

DRIVER SIDE : Diagnosis Procedure

INFOID:000000008158126

1.CHECK SEATBACK HEATER

1. Turn ignition switch OFF.
2. Disconnect seatback heater connector.
3. Check resistance between seatback heater terminals.

Seatback heater		Condition	Resistance (Ω) (Approx.)
Connector	Terminal		
B542	1 2	When heat sensor temperature is 20°C (68°F)	4.0 – 4.7

NOTE:

Resistance value changes according to temperature.

Is the inspection result normal?

- YES >> Replace seat cushion heater. Refer to [SE-199, "Exploded View"](#).
NO >> Replace seatback heater. Refer to [SE-199, "Exploded View"](#).

PASSENGER SIDE

PASSENGER SIDE : Description

INFOID:000000008158127

Warms the seat cushion.

PASSENGER SIDE : Component Function Check

INFOID:000000008158128

1.CHECK FUNCTION

Check that heated seat warms to preset temperature when operating heated seat switch to the optimal position.

Is the inspection result normal?

- YES >> Seatback heater function is OK.
NO >> Refer to [SE-116, "PASSENGER SIDE : Diagnosis Procedure"](#).

PASSENGER SIDE : Diagnosis Procedure

INFOID:000000008158129

1.CHECK SEATBACK HEATER

1. Turn ignition switch OFF.
2. Disconnect seatback heater connector.
3. Check resistance between seatback heater terminals.

SEATBACK HEATER

< DTC/CIRCUIT DIAGNOSIS >

Seatback heater			Condition	Resistance (Ω) (Approx.)
Connector	Terminal			
B582	1	2	When heat sensor temperature is 20°C (68°F)	4.0 – 4.7

NOTE:

Resistance value changes according to temperature.

Is the inspection result normal?

- YES >> Replace seat cushion heater. Refer to [SE-199, "Exploded View"](#).
- NO >> Replace seatback heater. Refer to [SE-199, "Exploded View"](#).

A
B
C
D
E
F
G
H
I
K
L
M
N
O
P

SE

HEATED SEAT SWITCH INDICATOR

< DTC/CIRCUIT DIAGNOSIS >

HEATED SEAT SWITCH INDICATOR DRIVER SIDE

DRIVER SIDE : Description

INFOID:000000008158130

Illuminates the indicator that indicates the operating status of heated seat.

DRIVER SIDE : Component Function Check

INFOID:000000008158131

1.CHECK FUNCTION

Check that the related indicator lamp illuminates when heated seat switch is set to ON.

Is the inspection result normal?

YES >> Heated seat switch indicator function is OK.

NO >> Refer to [SE-118. "DRIVER SIDE : Diagnosis Procedure"](#).

DRIVER SIDE : Diagnosis Procedure

INFOID:000000008158132

1.CHECK HEATED SEAT SWITCH INDICATOR GROUND CIRCUIT

1. Turn ignition switch OFF
2. Disconnect heated seat switch connector.
3. Check continuity between heated seat switch harness connector and ground.

Heated seat switch		Ground	Continuity
Connector	Terminal		
A/T models: M141 M/T models: M175	6		Existed

Is the inspection result normal?

YES >> Replace heated seat switch. Refer to [SE-231. "Removal and Installation"](#).

NO >> Repair or replace harness.

PASSENGER SIDE

PASSENGER SIDE : Description

INFOID:000000008158133

Illuminates the indicator that indicates the operating status of heated seat.

PASSENGER SIDE : Component Function Check

INFOID:000000008158134

1.CHECK FUNCTION

Check that the related indicator lamp illuminates when heated seat switch is set to ON.

Is the inspection result normal?

YES >> Heated seat switch indicator function is OK.

NO >> Refer to [SE-118. "PASSENGER SIDE : Diagnosis Procedure"](#).

PASSENGER SIDE : Diagnosis Procedure

INFOID:000000008158135

1.CHECK HEATED SEAT SWITCH INDICATOR GROUND CIRCUIT

1. Turn ignition switch OFF
2. Disconnect heated seat switch connector.
3. Check continuity between heated seat switch harness connector and ground.

Heated seat switch		Ground	Continuity
Connector	Terminal		
A/T models: M142 M/T models: M176	6		Existed

Is the inspection result normal?

HEATED SEAT SWITCH INDICATOR

< DTC/CIRCUIT DIAGNOSIS >

YES >> Replace heated seat switch. Refer to [SE-231, "Removal and Installation"](#).
NO >> Repair or replace harness.

A

B

C

D

E

F

G

H

I

SE

K

L

M

N

O

P

CLIMATE CONTROLLED SEAT SWITCH

< DTC/CIRCUIT DIAGNOSIS >

CLIMATE CONTROLLED SEAT SWITCH

Description

INFOID:000000008158136

Installed in the center console and transmits signals to climate controlled seat control unit in accordance with the HEAT or COOL switch operation and the temperature switch operation.

Component Function Check

INFOID:000000008158137

1.CHECK FUNCTION

Check that climate controlled seat activates when operating climate controlled seat control switch.

Is the inspection result normal?

- YES >> Climate controlled seat switch is OK.
 NO >> Refer to [SE-120, "Diagnosis Procedure"](#).

Diagnosis Procedure

INFOID:000000008158138

1.CHECK CLIMATE CONTROLLED SEAT CONTROL UNIT INPUT SIGNAL

- Turn ignition switch ON.
- Check voltage between climate controlled seat control unit harness connector and ground.

(+)			(-)	Condition	Voltage (V) (Approx.)	
Climate controlled seat control unit						
Connector	Terminal					
Driver side	B607	92	Ground	Climate controlled seat switch	LO COOL	0.8 - 1.5
					MID COOL	1.6 - 2.5
					HI COOL	2.6 - 4.2
					OFF	0
	91	Climate controlled seat switch		LO HEAT	0.8 - 1.5	
				MID HEAT	1.6 - 2.5	
				HI HEAT	2.6 - 4.2	
				OFF	0	
Passenger side	B627	92	Ground	Climate controlled seat switch	LO COOL	0.8 - 1.5
					MID COOL	1.6 - 2.5
					HI COOL	2.6 - 4.2
					OFF	0
	91	Climate controlled seat switch		LO HEAT	0.8 - 1.5	
				MID HEAT	1.6 - 2.5	
				HI HEAT	2.6 - 4.2	
				OFF	0	

Is the inspection result normal?

- YES >> Climate controlled seat switch circuit is OK.
 NO-1 >> HEAT or COOL mode is NG :GO TO 2.
 NO-2 >> HEAT and COOL modes are NG : GO TO 3.

2.CHECK CLIMATE CONTROLLED SEAT SWITCH CIRCUIT

- Turn ignition switch OFF.
- Disconnect climate controlled seat switch connector and climate controlled seat control unit connector.
- Check continuity between climate controlled seat switch harness connector and climate controlled seat control unit harness connector.

CLIMATE CONTROLLED SEAT SWITCH

< DTC/CIRCUIT DIAGNOSIS >

Climate controlled seat switch			Climate cotrolled seat control unit		Continuity
Connector		Terminal	Connector	Terminal	
Driver side	COOL	M177	2	B607	Existed
	HEAT		3		
Passenger side	COOL	M178	2	B627	
	HEAT		3		

4. Check continuity between climate controlled seat switch harness connector and ground.

Climate controlled seat switch			Ground	Continuity
Connector		Terminal		
Driver side	COOL	M177	2	Not existed
	HEAT		3	
Passenger side	COOL	M178	2	
	HEAT		3	

Is the inspection result normal?

YES >> GO TO 5.

NO >> Repair or replace harness.

3. CHECK CLIMATE CONTROLLED SEAT SWITCH POWER SUPPLY

- Turn ignition switch OFF.
- Disconnect climate controlled seat switch connector.
- Turn ignition switch ON.
- Check voltage between climate controlled seat switch harness connector and ground.

Climate controlled seat switch			Ground	Voltage (V) (Approx.)
Connector		Terminal		
Driver side	M177	1	Ground	Battery voltage
Passenger side	M178	1		

Is the inspection result normal?

YES >> GO TO 5.

NO >> GO TO 4.

4. CHECK CLIMATE CONTROLLED SEAT SWITCH POWER SUPPLY CIRCUIT

- Turn ignition switch OFF.
- Disconnect climate controlled seat control unit connector.
- Check continuity between climate controlled seat switch harness connector and climate controlled seat control unit harness connector.

Climate controlled seat switch			Climate cotrolled seat control unit		Continuity
Connector		Terminal	Connector	Terminal	
Driver side	M177	1	B607	94	Existed
Passenger side	M178	1	B627	94	

4. Check continuity between climate controlled seat switch harness connector and ground.

Climate controlled seat switch			Ground	Continuity
Connector		Terminal		
Driver side	M177	1	Ground	Not existed
Passenger side	M178	1		

Is the inspection result normal?

CLIMATE CONTROLLED SEAT SWITCH

< DTC/CIRCUIT DIAGNOSIS >

- YES >> Replace climate controlled seat control unit. Refer to [SE-211, "Disassembly and Assembly"](#).
NO >> Repair or replace harness.

5.CHECK CLIMATE CONTROLLED SEAT SWITCH

Check climate controlled seat switch.

Refer to [SE-122, "Component Inspection"](#).

Is the inspection result normal?

- YES >> GO TO 6.
NO >> Replace climate controlled seat switch. Refer to [SE-232, "Removal and Installation"](#).

6.CHECK INTERMITTENT INCIDENT

Refer to [GI-42, "Intermittent Incident"](#).

>> INSPECTION END

Component Inspection

INFOID:000000008158139

1.CHECK CLIMATE CONTROLLED SEAT SWITCH

1. Turn ignition OFF.
2. Disconnect climate controlled seat switch connector.
3. Check climate controlled seat switch terminals.

Climate controlled seat switch		Terminal		Condition			Continuity
Driver side	M177	2	1	Climate controlled seat switch	COOL mode	ON	Existed
						OFF	Not existed
		3			HEAT mode	ON	Existed
						OFF	Not existed
Passenger side	M178	2	1	Climate controlled seat switch	COOL mode	ON	Existed
						OFF	Not existed
		3			HEAT mode	ON	Existed
						OFF	Not existed

Is the inspection result normal?

- YES >> Climate controlled seat switch is OK.
NO >> Replace climate controlled seat switch. Refer to [SE-232, "Removal and Installation"](#).

SEATBACK THERMAL ELECTRIC DEVICE

< DTC/CIRCUIT DIAGNOSIS >

SEATBACK THERMAL ELECTRIC DEVICE

Description

INFOID:000000008158140

Installed in the seatback backside and heats or cools the airflow from the climate controlled seat blower motor in accordance with the control from the climate controlled seat control unit.

Component Function Check

INFOID:000000008158141

1.CHECK FUNCTION

Checks whether or not the temperature of the seatback thermal electric device changes in accordance with the HEAT or COOL switch operation of the climate controlled seat control switch.

Is the inspection result normal?

- YES >> Seatback thermal device function is OK.
 NO >> Refer to [SE-123. "Diagnosis Procedure"](#).

Diagnosis Procedure

INFOID:000000008158142

1.CHECK SEATBACK THERMAL ELECTRIC DEVICE SIGNAL

- Turn ignition switch ON.
- Check voltage between seatback thermal electric device harness connector and ground.

(+)		Terminal	(-)	Condition	Voltage (V) (Approx.)
Seatback thermal electric device					
Connector					
Driver side	B602	88	Ground	Climate controlled seat switch	HEAT and COOL 0 - battery voltage*
		85		Other than above	0
Passenger side	B622			88	Climate controlled seat switch
		85		Other than above	0

*:It changes between battery voltage or 0V

NOTE:

Wait 1 minute or more after the activation start, and then start the measurement.

Is the inspection result normal?

- YES >> Replace seatback thermal electric device.
 NO >> GO TO 2.

2.CHECK SEATBACK THERMAL ELECTRIC DEVICE CIRCUIT

- Turn ignition switch OFF.
- Disconnect climate controlled seat control unit connector and seatback thermal electric device connector.
- Check continuity between climate controlled seat control unit harness connector and seatback thermal electric device harness connector.

Climate controlled seat control unit		Seatback thermal electric device		Continuity
Connector	Terminal	Connector	Terminal	
Driver side	B606	B602	88	Existed
			85	
Passenger side	B626	B622	88	
			85	

- Check continuity between climate controlled seat control unit harness connector and ground.

SEATBACK THERMAL ELECTRIC DEVICE

< DTC/CIRCUIT DIAGNOSIS >

Climate controlled seat control unit			Ground	Continuity
Connector		Terminal		Not existed
Driver side	B606	88		
		85		
Passenger side	B626	88		
		85		

Is the inspection result normal?

- YES >> Replace climate controlled seat control unit. Refer to [SE-211, "Disassembly and Assembly"](#).
- NO >> Repair or replace harness.

SEATBACK THERMAL ELECTRIC DEVICE SENSOR

< DTC/CIRCUIT DIAGNOSIS >

SEATBACK THERMAL ELECTRIC DEVICE SENSOR

Description

INFOID:000000008158143

Measures seatback temperature.

Diagnosis Procedure

INFOID:000000008158144

1. CHECK SEATBACK THERMAL ELECTRIC DEVICE SENSOR CIRCUIT

1. Turn ignition switch ON.
2. Check voltage between climate controlled seat control unit harness connector and ground.

(+)		Terminal	(-)	Condition	Voltage (V) (Approx.)
Climate controlled seat control unit					
Connector					
Driver side	B608	105	Ground	Climate controlled seat operated	1 - 5
Passenger side	B628				

Is the inspection result normal?

YES >> Seatback thermal electric device sensor circuit is OK.

NO >> GO TO 2.

2. CHECK SEATBACK THERMAL ELECTRIC DEVICE SENSOR HARNESS

1. Turn ignition switch OFF.
2. Disconnect climate controlled seat control unit connector and seatback thermal electric device connector.
3. Check continuity between climate controlled seat control unit harness connector and seatback thermal electric device harness connector.

Climate controlled seat control unit		Seatback thermal electric device		Continuity
Connector	Terminal	Connector	Terminal	
Driver side	B608	B602	105	Existed
			104	
Passenger side	B628	B622	105	
			104	

4. Check continuity between climate controlled seat control unit harness connector and ground.

Climate controlled seat control unit		Terminal	Ground	Continuity
Connector	Terminal			
Driver side	B608	105	Ground	Not existed
		104		
Passenger side	B628	105		
		104		

Is the inspection result normal?

YES >> GO TO 3.

NO >> Repair or replace harness.

3. CHECK SEATBACK THERMAL ELECTRIC DEVICE SENSOR

Check resistance between seatback thermal electric device connector.

Seatback thermal electric device		Terminal		Resistance (K Ω) (Approx.)
Connector				
Driver side	B602	105	104	1
Passenger side	B622			

SEATBACK THERMAL ELECTRIC DEVICE SENSOR

< DTC/CIRCUIT DIAGNOSIS >

Is the inspection result normal?

- YES >> Replace climate controlled seat control unit. Refer to [SE-211, "Disassembly and Assembly"](#).
- NO >> Replace seatback thermal electric device.

SEAT CUSHION THERMAL ELECTRIC DEVICE

< DTC/CIRCUIT DIAGNOSIS >

SEAT CUSHION THERMAL ELECTRIC DEVICE

Description

INFOID:000000008158145

Installed in the seat cushion backside and heats or cools the airflow from the climate controlled seat blower motor in accordance with the control from the climate controlled seat control unit.

Component Function Check

INFOID:000000008158146

1. CHECK FUNCTION

Checks whether or not the temperature of the seatback thermal electric device changes in accordance with the HEAT or COOL switch operation of the climate controlled seat control switch.

Is the inspection result normal?

- YES >> Seatack thermal device function is OK.
 NO >> Refer to [SE-123. "Diagnosis Procedure"](#).

Diagnosis Procedure

INFOID:000000008158147

1. CHECK SEAT CUSHION THERMAL ELECTRIC DEVICE SIGNAL

- Turn ignition switch ON.
- Check voltage between seat cushion thermal electric device harness connector and ground.

(+)		Terminal	(-)	Condition	Voltage (V) (Approx.)
Seat cushion thermal electric device					
Connector					
Driver side	B603	87	Ground	Climate controlled seat switch	HEAT and COOL 0 - battery voltage*
		86		Other than above	0
Passenger side	B623			87	Climate controlled seat switch
		86		Other than above	0

*:It changes between battery voltage or 0V

NOTE:

Wait 1 minute or more after the activation start, and then start the measurement.

Is the inspection result normal?

- YES >> Replace seat cushion thermal electric device.
 NO >> GO TO 2.

2. CHECK SEAT CUSHION THERMAL ELECTRIC DEVICE CIRCUIT

- Turn ignition switch OFF.
- Disconnect climate controlled seat control unit connector and seat cushion thermal electric device connector.
- Check continuity between climate controlled seat control unit harness connector and seat cushion thermal electric device harness connector.

Climate controlled seat control unit		Seat cushion thermal electric device		Continuity
Connector	Terminal	Connector	Terminal	
Driver side	B606	B603	87	Existed
			86	
Passenger side	B626	B623	87	
			86	

SEAT CUSHION THERMAL ELECTRIC DEVICE

< DTC/CIRCUIT DIAGNOSIS >

4. Check continuity between climate controlled seat control unit harness connector and ground.

Climate controlled seat control unit			Ground	Continuity
Connector		Terminal		
Driver side	B606	87		Not existed
		86		
Passenger side	B626	87		
		86		

Is the inspection result normal?

YES >> Replace climate controlled seat control unit. Refer to [SE-211, "Disassembly and Assembly"](#).

NO >> Repair or replace harness.

SEAT CUSHION THERMAL ELECTRIC DEVICE SENSOR

< DTC/CIRCUIT DIAGNOSIS >

SEAT CUSHION THERMAL ELECTRIC DEVICE SENSOR

Description

INFOID:000000008158148

Measures seat cushion temperature.

Diagnosis Procedure

INFOID:000000008158149

1. CHECK SEAT CUSHION THERMAL ELECTRIC DEVICE SENSOR CIRCUIT

1. Turn ignition switch ON.
2. Check voltage between climate controlled seat control unit harness connector and ground.

(+)		Terminal	(-)	Condition	Voltage (V) (Approx.)
Climate controlled seat control unit					
Connector					
Driver side	B608	103	Ground	Climate controlled seat operated	1 - 5
Passenger side	B628				

Is the inspection result normal?

YES >> Seat cushion thermal electric device sensor circuit is OK.

NO >> GO TO 2.

2. CHECK SEAT CUSHION THERMAL ELECTRIC DEVICE SENSOR HARNESS

1. Turn ignition switch OFF.
2. Disconnect climate controlled seat control unit connector and seat cushion thermal electric device connector.
3. Check continuity between climate controlled seat control unit harness connector and seat cushion thermal electric device harness connector.

Climate controlled seat control unit		Seat cushion thermal electric device		Continuity
Connector	Terminal	Connector	Terminal	
Driver side	B608	B603	103	Existed
			102	
Passenger side	B628	B623	103	
			102	

4. Check continuity between climate controlled seat control unit harness connector and ground.

Climate controlled seat control unit		Terminal	Ground	Continuity
Connector				
Driver side	B608	103	Ground	Not existed
		102		
Passenger side	B628	103		
		102		

Is the inspection result normal?

YES >> GO TO 3.

NO >> Repair or replace harness.

3. CHECK SEAT CUSHION THERMAL ELECTRIC DEVICE SENSOR

Check resistance between seat cushion thermal electric device connector.

SEAT CUSHION THERMAL ELECTRIC DEVICE SENSOR

< DTC/CIRCUIT DIAGNOSIS >

Seat cushion thermal electric device		Terminal		Resistance (K Ω) (Approx.)
Connector				
Driver side	B603	102	103	1
Passenger side	B623			

Is the inspection result normal?

- YES >> Replace climate controlled seat control unit. Refer to [SE-210, "Removal and Installation"](#).
NO >> Replace seat cushion thermal electric device.

CLIMATE CONTROLLED SEATBACK BLOWER MOTOR

< DTC/CIRCUIT DIAGNOSIS >

CLIMATE CONTROLLED SEATBACK BLOWER MOTOR

Description

INFOID:000000008158150

Sends air flow to the seatback.

Component Function Check

INFOID:000000008158151

1. CHECK FUNCTION

When turning the climate controlled seat switch to the HEAT and COOL mode position, check that the climate controlled seatback blower is operated in each specific mode.

Is the inspection result normal?

- YES >> Climate controlled seatback blower motor is OK.
- NO >> Refer to [SE-134, "Diagnosis Procedure"](#).

Diagnosis Procedure

INFOID:000000008158152

1. CHECK CLIMATE CONTROLLED SEATBACK BLOWER MOTOR POWER SUPPLY

1. Turn ignition switch ON.
2. Check voltage between climate controlled seatback blower motor harness connector and ground.

(+)		Terminal	(-)	Condition	Voltage (V) (Approx.)	
Climate controlled seatback blower motor						
Connector						
Driver side	B604	99	Ground	Climate controlled seat switch	HEAT mode	Battery voltage
					COOL mode	
					Other than above	0
Passenger side	B624	99	Ground	Climate controlled seat switch	HEAT mode	Battery voltage
					COOL mode	
					Other than above	0

Is the inspection result normal?

- YES >> GO TO 3.
- NO >> GO TO 2.

2. CHECK CLIMATE CONTROLLED BLOWER MOTOR POWER SUPPLY CIRCUIT

1. Turn ignition switch OFF.
2. Disconnect climate controlled blower motor connector and climate controlled seat control unit connector.
3. Check continuity between climate controlled seatback blower motor harness connector and climate controlled seat control unit harness connector.

Climate controlled seatback blower motor		Climate controlled seat control unit		Continuity
Connector	Terminal	Connector	Terminal	
Driver side	B604	B608	99	Existed
Passenger side	B624	B628		

4. Check continuity between climate controlled seatback blower motor harness connector and ground.

Climate controlled seatback blower motor		Terminal	Ground	Continuity
Connector				
Driver side	B604	99	Ground	Not existed
Passenger side	B624			

Is the inspection result normal?

- YES >> Replace climate controlled seat control unit. Refer to [SE-211, "Disassembly and Assembly"](#).
- NO >> Repair or replace harness.

CLIMATE CONTROLLED SEATBACK BLOWER MOTOR

< DTC/CIRCUIT DIAGNOSIS >

3. CHECK CLIMATE CONTROLLED SEATBACK BLOWER MOTOR SPEED CONTROL SIGNAL

Check voltage between climate controlled seatback blower motor harness connector and ground.

(+)		Terminal	(-)	Condition	Voltage (V) (Approx.)	
Climate controlled seatback blower motor						
Connector						
Driver side	B604	96	Ground	Climate controlled seat	HEAT mode	7.5 - 8
					LO COOL	6.5
MID COOL	8					
Passenger side	B624				HI COOL	12
					Other than above	0

Is the inspection result normal?

YES >> GO TO 5.

NO >> GO TO 4.

4. CHECK CLIMATE CONTROLLED SEATBACK BLOWER MOTOR SPEED CONTROL SIGNAL CIRCUIT

1. Turn ignition switch OFF.
2. Disconnect climate controlled seatback blower motor connector and climate controlled seat control unit connector.
3. Check continuity between climate controlled seatback blower motor harness connector and climate controlled seat control unit harness connector.

Climate controlled seatback blower motor		Climate controlled seat control unit		Continuity
Connector	Terminal	Connector	Terminal	
Driver side	B604	B608	96	Existed
Passenger side	B624	B628		

4. Check continuity between climate controlled seatback blower motor harness connector and ground.

Climate controlled seatback blower motor		Ground	Continuity
Connector	Terminal		
Driver side	B604	96	Not existed
Passenger side	B624		

Is the inspection result normal?

YES >> Replace climate controlled seat control unit. Refer to [SE-211, "Disassembly and Assembly"](#).

NO >> Repair or replace harness.

5. CHECK CLIMATE CONTROLLED SEATBACK BLOWER MOTOR GROUND CIRCUIT

1. Turn ignition switch OFF.
2. Disconnect climate controlled seatback blower motor and climate controlled seat control unit connector.
3. Check continuity between climate controlled seatback blower motor harness connector and climate controlled seat control unit harness connector.

Climate controlled seatback blower motor		Climate controlled seat control unit		Continuity
Connector	Terminal	Connector	Terminal	
Driver side	B604	B608	98	Existed
Passenger side	B624	B628		

4. Check continuity between climate controlled seatback blower motor harness connector and ground.

CLIMATE CONTROLLED SEATBACK BLOWER MOTOR

< DTC/CIRCUIT DIAGNOSIS >

Climate controlled seatback blower motor		Terminal	Ground	Continuity
Connector				Continuity
Driver side	B604	98		Not existed
Passenger side	B624			Continuity

Is the inspection result normal?

YES >> GO TO 6.

NO >> Repair or replace harness.

6.CHECK CLIMATE CONTROLLED SEATBACK BLOWER MOTOR GROUND

1. Connect climate controlled seat control unit connector.
2. Check continuity between climate controlled seatback blower motor harness connector and ground.

Climate controlled seat control unit		Terminal	Ground	Continuity
Connector				Continuity
Driver side	B608	98		Existed
Passenger side	B628			Continuity

Is the inspection result normal?

YES >> Replace climate controlled seatback blower motor. Refer to [SE-211, "Disassembly and Assembly"](#).

NO >> Replace climate controlled seat control unit. Refer to [SE-211, "Disassembly and Assembly"](#).

A
B
C
D
E
F
G
H
I
K
L
M
N
O
P

SE

CLIMATE CONTROLLED SEAT CUSHION BLOWER MOTOR

< DTC/CIRCUIT DIAGNOSIS >

CLIMATE CONTROLLED SEAT CUSHION BLOWER MOTOR

Description

INFOID:000000008158153

Sends air flow to the seat cushion.

Component Function Check

INFOID:000000008158154

1.CHECK FUNCTION

When turning the climate controlled seat switch to the HEAT and COOL mode position, check that the climate controlled seat cushion blower is operated in each specific mode.

Is the inspection result normal?

YES >> Climate controlled seat cushion blower motor is OK.

NO >> Refer to [SE-134, "Diagnosis Procedure"](#).

Diagnosis Procedure

INFOID:000000008158155

1.CHECK CLIMATE CONTROLLED SEAT CUSHION BLOWER MOTOR POWER SUPPLY

1. Turn ignition switch ON.
2. Check voltage between climate controlled seat cushion blower motor harness connector and ground.

(+)		Terminal	(-)	Condition	Voltage (V) (Approx.)	
Climate controlled seat cushion blower motor						
Connector						
Driver side	B605	101	Ground	Climate controlled seat switch	HEAT mode	Battery voltage
					COOL mode	
					Other than above	
Passenger side	B625			Climate controlled seat switch	HEAT mode	Battery voltage
					COOL mode	
					Other than above	

Is the inspection result normal?

YES >> GO TO 3.

NO >> GO TO 2.

2.CHECK CLIMATE CONTROLLED BLOWER MOTOR POWER SUPPLY CIRCUIT

1. Turn ignition switch OFF.
2. Disconnect climate controlled blower motor connector and climate controlled seat control unit connector.
3. Check continuity between climate controlled seat cushion blower motor harness connector and climate controlled seat control unit harness connector.

Climate controlled seat cushion blower motor		Climate controlled seat control unit		Continuity
Connector	Terminal	Connector	Terminal	
Driver side	B605	B608	101	Existed
Passenger side	B625	B628		

4. Check continuity between climate controlled seat cushion blower motor harness connector and ground.

Climate controlled seat cushion blower motor		Terminal	Ground	Continuity
Connector				
Driver side	B605	101	Ground	Not existed
Passenger side	B625			

Is the inspection result normal?

YES >> Replace climate controlled seat control unit. Refer to [SE-211, "Disassembly and Assembly"](#).

NO >> Repair or replace harness.

CLIMATE CONTROLLED SEAT CUSHION BLOWER MOTOR

< DTC/CIRCUIT DIAGNOSIS >

3. CHECK CLIMATE CONTROLLED SEAT CUSHION BLOWER MOTOR SPEED CONTROL SIGNAL

Check voltage between climate controlled seat cushion blower motor harness connector and ground.

(+)		Terminal	(-)	Condition	Voltage (V) (Approx.)	
Climate controlled seat cushion blower motor						
Connector						
Driver side	B605	97	Ground	Climate controlled seat	HEAT mode	7.5 - 8
					LO COOL	6.5
MID COOL	8					
Passenger side	B625				HI COOL	12
					Other than above	0

Is the inspection result normal?

YES >> GO TO 5.

NO >> GO TO 4.

4. CHECK CLIMATE CONTROLLED SEAT CUSHION BLOWER MOTOR SPEED CONTROL SIGNAL CIRCUIT

- Turn ignition switch OFF.
- Disconnect climate controlled seat cushion blower motor connector and climate controlled seat control unit connector.
- Check continuity between climate controlled seat cushion blower motor harness connector and climate controlled seat control unit harness connector.

Climate controlled seat cushion blower motor		Climate controlled seat control unit		Continuity
Connector	Terminal	Connector	Terminal	
Driver side	B605	B608	97	Existed
Passenger side	B625	B628		

- Check continuity between climate controlled seat cushion blower motor harness connector and ground.

Climate controlled seat cushion blower motor		Ground	Continuity
Connector	Terminal		
Driver side	B605	97	Not existed
Passenger side	B625		

Is the inspection result normal?

YES >> Replace climate controlled seat control unit. Refer to [SE-211. "Disassembly and Assembly"](#).

NO >> Repair or replace harness.

5. CHECK CLIMATE CONTROLLED SEAT CUSHION BLOWER MOTOR GROUND CIRCUIT

- Turn ignition switch OFF.
- Disconnect climate controlled seat cushion blower motor and climate controlled seat control unit connector.
- Check continuity between climate controlled seat cushion blower motor harness connector and climate controlled seat control unit harness connector.

Climate controlled seat cushion blower motor		Climate controlled seat control unit		Continuity
Connector	Terminal	Connector	Terminal	
Driver side	B605	B608	98	Existed
Passenger side	B625	B628		

- Check continuity between climate controlled seat cushion blower motor harness connector and ground.

CLIMATE CONTROLLED SEAT CUSHION BLOWER MOTOR

< DTC/CIRCUIT DIAGNOSIS >

Climate controlled seat cushion blower motor		Terminal	Ground	Continuity
Connector				Not existed
Driver side	B605	98		
Passenger side	B625			

Is the inspection result normal?

YES >> GO TO 6.

NO >> Repair or replace harness.

6.CHECK CLIMATE CONTROLLED SEAT BLOWER MOTOR GROUND

1. Connect climate controlled seat control unit connector.
2. Check continuity between climate controlled seat cushion blower motor harness connector and ground.

Climate controlled seat cushion blower motor		Terminal	Ground	Continuity
Connector				Existed
Driver side	B605	98		
Passenger side	B625			

Is the inspection result normal?

YES >> Replace climate controlled seat cushion blower motor. Refer to [SE-211, "Disassembly and Assembly"](#).

NO >> Replace climate controlled seat control unit. Refer to [SE-211, "Disassembly and Assembly"](#).

CLIMATE CONTROLLED SEAT SWITCH INDICATOR

< DTC/CIRCUIT DIAGNOSIS >

CLIMATE CONTROLLED SEAT SWITCH INDICATOR

Description

INFOID:000000008158156

- Turns ON the indicator that indicates the operating status of climate controlled seat HEAT or COOL mode.

Component Function Check

INFOID:000000008158157

1.CHECK FUNCTION

Check that the related indicator lamp illuminates when climate controlled seat switch is set to HEAT or COOL mode.

Is the inspection result normal?

- YES >> Climate controlled seat switch indicator function is OK.
- NO >> Refer to [SE-137, "Diagnosis Procedure"](#).

Diagnosis Procedure

INFOID:000000008158158

1.CHECK CLIMATECONTROLLED SEAT SWITCH GROUND CIRCUIT

1. Turn ignition switch OFF.
2. Disconnect climate controlled seat switch connector.
3. Check continuity between climate controlled seat switch harness connector and ground.

Climate controlled seat switch		Ground	Continuity
Connector	Terminal		
Driver side	M177	6	Existed
Passenger side	M178		

Is the inspection result normal?

- YES >> GO TO 2.
- NO >> Repair or replace harness.

2.CHECK CLIMATE CONTROLLED SEAT CONTROL UNIT OUTPUT SIGNAL

1. Turn ignition switch ON.
2. Check voltage between climate controlled seat control unit harness connector and ground.

Climate controlled seat control unit		Terminal	(-)	Condition	Voltage (V) (Approx.)
Connector	(+)				
Driver side	B608	95	Ground	HEAT mode	Battery voltage
		100		OFF	0
Passenger side	B628			95	COOL mode
		100			OFF

Is the inspection result normal?

- YES >> GO TO 3.
- NO >> Replace climate controlled seat control unit. Refer to [SE-211, "Disassembly and Assembly"](#).

3.CHECK CLIMATE CONTROLLED SEAT SWITCH INDICATOR CIRCUIT

1. Turn ignition switch OFF.
2. Disconnect climate controlled seat control unit connector.
3. Check continuity between climate controlled seat switch harness connector and climate controlled seat control unit harness connector.

CLIMATE CONTROLLED SEAT SWITCH INDICATOR

< DTC/CIRCUIT DIAGNOSIS >

Climate controlled seat switch		Climate controlled seat control unit		Continuity
Connector	Terminal	Connector	Terminal	
Driver side	M177	B608	4	100
			5	95
Passenger side	M178	B628	4	100
			5	95

4. Check continuity between climate controlled seat switch harness connector and ground.

Climate controlled seat switch		Ground	Continuity
Connector	Terminal		
Driver side	M177	Ground	4
			5
Passenger side	M178		4
			5

Is the inspection result normal?

YES >> Replace climate controlled seat switch. Refer to [SE-232, "Removal and Installation"](#).

NO >> Repair or replace harness.

CLIMATE CONTROLLED SEAT BLOWER FILTER

< DTC/CIRCUIT DIAGNOSIS >

CLIMATE CONTROLLED SEAT BLOWER FILTER SEATBACK BLOWER MOTOR

SEATBACK BLOWER MOTOR : Diagnosis Procedure

INFOID:000000008158159

1. CHECK CLIMATE CONTROLLED SEATBACK BLOWER FILTER

Remove climate controlled seatback blower motor filter and check that there is no clogging by dirt or foreign matters.

Is the inspection result normal?

YES >> INSPECTION END

NO >> Replace climate controlled seatback blower filter. Refer to [SE-233, "SEATBACK : Removal and Installation"](#).

SEAT CUSHION BLOWER MOTOR

SEAT CUSHION BLOWER MOTOR : Diagnosis Procedure

INFOID:000000008158160

1. CHECK CLIMATE CONTROLLED SEAT CUSHION BLOWER FILTER

Remove climate controlled seat cushion blower motor filter and check that there is no clogging by dirt or foreign matters.

Is the inspection result normal?

YES >> INSPECTION END

NO >> Replace climate controlled seat cushion blower filter. Refer to [SE-233, "SEAT CUSHION : Removal and Installation"](#).

A
B
C
D
E
F
G
H
I
K
L
M
N
O
P

SE

SIDE SUPPORT

< DTC/CIRCUIT DIAGNOSIS >

SIDE SUPPORT

Wiring Diagram - SIDE SUPPORT -

INFOID:000000008158162

For connector terminal arrangements, harness layouts, and alphabets in a  (option abbreviation; if not described in wiring diagram), refer to [GI-12, "Connector Information"](#).

SIDE SUPPORT

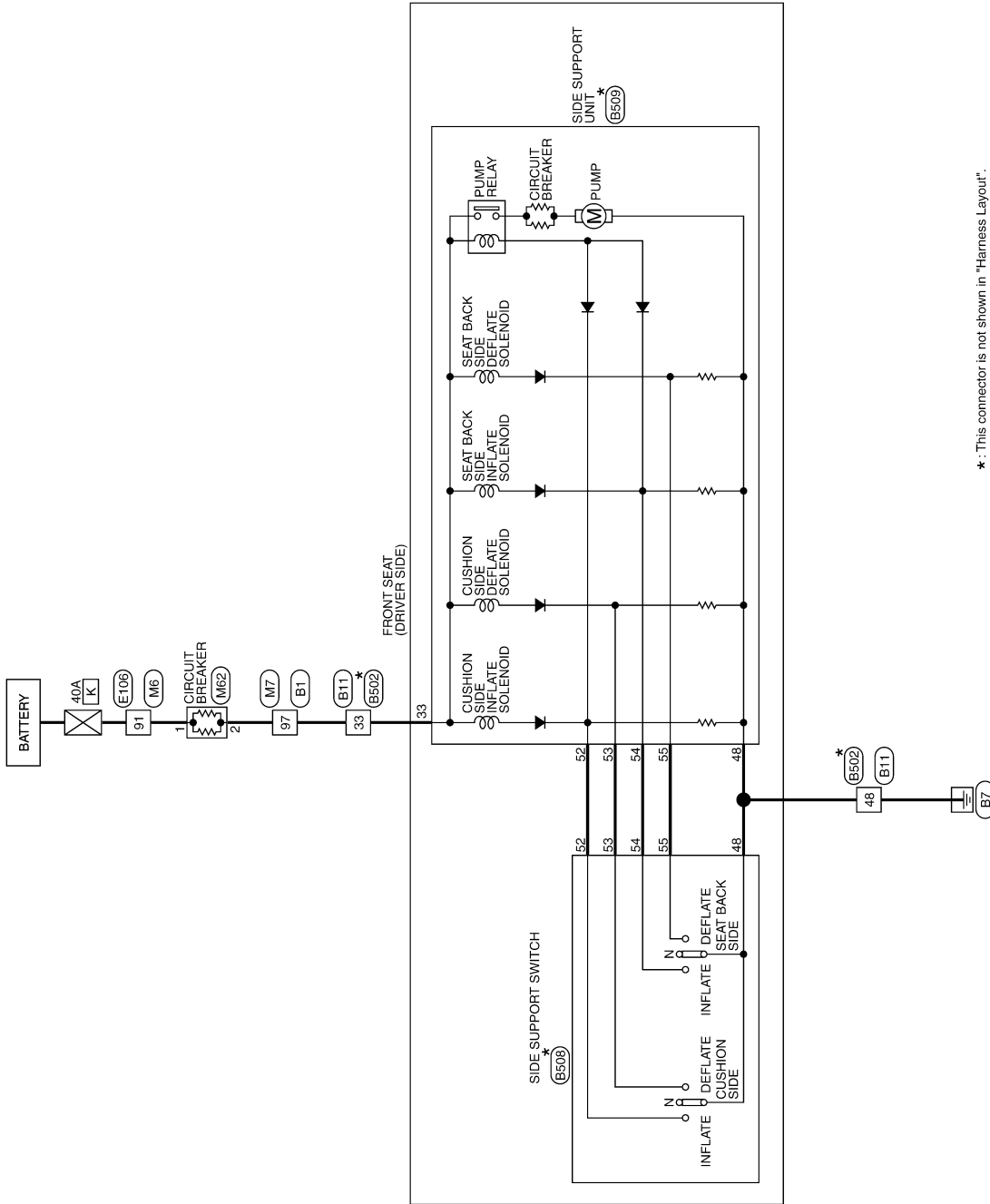

*: This connector is not shown in "Harness Layout".

2010/10/12

JCJWM1786GB

A
B
C
D
E
F
G
H
I
SE
K
L
M
N
O
P

DRIVER SEAT CONTROL UNIT (WITHOUT AUTOMATIC DRIVE POSITIONER)

< ECU DIAGNOSIS INFORMATION >

ECU DIAGNOSIS INFORMATION

DRIVER SEAT CONTROL UNIT (WITHOUT AUTOMATIC DRIVE POSITIONER)

Reference Value

INFOID:000000008158163

VALUES ON THE DIAGNOSIS TOOL

NOTE:

The following table includes information (items) inapplicable to this vehicle. For information (items) applicable to this vehicle, refer to CONSULT display items.

CONSULT MONITOR ITEM

Monitor Item	Condition		Value/Status
SLIDE SW-FR	Sliding switch (front)	Operate	ON
		Release	OFF
SLIDE SW-RR	Sliding switch (rear)	Operate	ON
		Release	OFF
FORWARD SW	Seat back	Folded down	ON
		Other than above	OFF
WALK-IN SW	Power walk-in switch	Pressed	ON
		Other than above	OFF
FWD LIMIT SW	Seat sliding	Front edge	ON
		Other than above	OFF
SEAT BELT SW	Seat belt	Front edge	ON
		Other than above	OFF
DETENT SW*1	A/T selector lever	P position	OFF
		Other than above	ON
PARK BRAKE SW*2	Parking brake	Applied	ON
		Release	OFF
SLIDE PULSE	Seat sliding	Forward	The numeral value decreases *3
		Backward	The numeral value increases *3
		Other than above	No change to numeral value *3

*1: A/T model

*2: M/T model

*3: The value at the position attained when the battery is connected is regarded as 32768.

TERMINAL LAYOUT

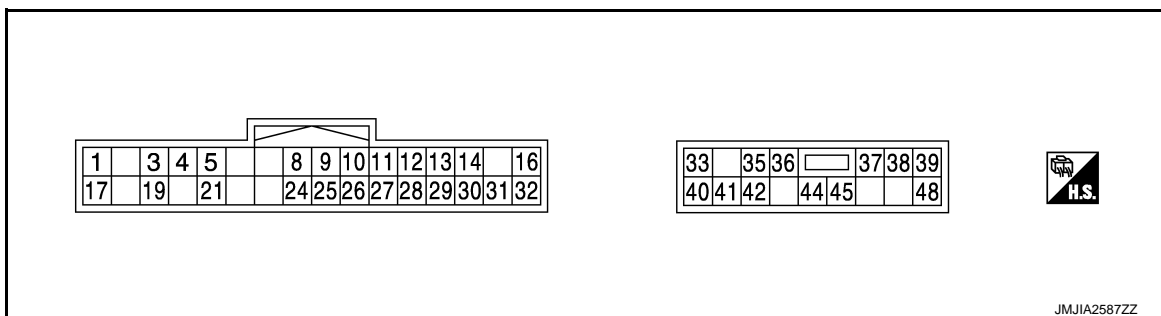

PHYSICAL VALUES

DRIVER SEAT CONTROL UNIT (WITHOUT AUTOMATIC DRIVE POSITIONER)

< ECU DIAGNOSIS INFORMATION >

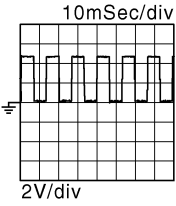
Terminal No. (Wire color)		Description		Condition		Voltage (V) (Approx.)
(+)	(-)	Signal name	Input/ Out- put			
3 (R/Y)	—	CAN-H	—	—		—
4 (O/B)	Ground	Sliding limit switch signal	Input	Seat sliding front edge	0	
				Other than above*	5	
5 (L)	Ground	Seat belt buckle switch signal (driver side)	Input	Ignition switch OFF and seat belt fas- tened*	5	
				Ignition switch ON and seat belt re- leased	Battery voltage	
				Other than above	0	
11 (BR)	Ground	Sliding switch back- ward signal	Input	Sliding switch	Operate (backward)	0
					Release	Battery voltage
12 (SB)	Ground	Reclining switch backward signal	Input	Reclining switch	Operate (backward)	0
					Release	Battery voltage
13 (LG/R)	Ground	Lifting switch (front) downward signal	Input	Lifting switch (front)	Operate (downward)	0
					Release	Battery voltage
14 (G/B)	Ground	Lifting switch (rear) downward signal	Input	Lifting switch (rear)	Operate (downward)	0
					Release	Battery voltage
16 (O)	Ground	Sensor power sup- ply	Out- put	—		Battery voltage
19 (V)	—	CAN-L	—	—		—
24 (R)	Ground	Sliding sensor sig- nal	Input	Seat sliding	Operate	 10mSec/div 2V/div JMJA0119ZZ
					Stop	0 or 5
26 (Y)	Ground	Sliding switch for- ward signal	Input	Sliding switch	Operate (forward)	0
					Release	Battery voltage
27 (R/G)	Ground	Reclining switch for- ward signal	Input	Reclining switch	Operate (forward)	0
					Release	Battery voltage
28 (W/B)	Ground	Lifting switch (front) upward signal	Input	Seat lifting switch (front)	Operate (upward)	0
					Release	Battery voltage
29 (P/L)	Ground	Lifting switch (rear) upward signal	Input	Seat lifting switch (rear)	Operate (upward)	0
					Release	Battery voltage

A

B

C

D

E

F

G

H

I

SE

K

L

M

N

O

P

DRIVER SEAT CONTROL UNIT (WITHOUT AUTOMATIC DRIVE POSITIONER)

< ECU DIAGNOSIS INFORMATION >

Terminal No. (Wire color)		Description		Condition		Voltage (V) (Approx.)
(+)	(-)	Signal name	Input/ Out- put			
30 (P)	Ground	Power walk-in switch signal	Input	Power walk-in switch	Pressed	0
					Other than above	Battery voltage
31 (GR)	Ground	Sensor ground	—	—	—	0
32 (B/W)	Ground	Ground (signal)	—	—	—	0
33 (R)	Ground	Power source (C/B)	Input	—	—	Battery voltage
35 (W/R)	Ground	Sliding motor for- ward output	Out- put	Seat sliding	Operate (forward)	Battery voltage
					Release	0
36 (G/Y)	Ground	Reclining motor for- ward output signal	Out- put	Seat reclining	Operate (forward)	Battery voltage
					Release	0
37 (G/W)	Ground	Lifting motor (front) downward output	Out- put	Seat lifting (front)	Operate (downward)	Battery voltage
					Stop	0
38 (L/Y)	Ground	Lifting motor (rear) upward output	Out- put	Seat lifting (rear)	Operate (upward)	Battery voltage
					Stop	0
39 (R/B)	Ground	Lifting motor (rear) downward output	Out- put	Seat lifting (rear)	Operate (downward)	Battery voltage
					Stop	0
40 (R/W)	Ground	Power source (Fuse)	Input	—	—	Battery voltage
41 (Y/G)	Ground	Forward switch sig- nal	Input	Seatback is folded down	—	0
				Other than above*	—	5
42 (W)	Ground	Sliding motor back- ward output	Out- put	Seat sliding	Operate (backward)	Battery voltage
					Stop	0
44 (P)	Ground	Reclining motor backward output	Out- put	Seat reclining	Operate (backward)	Battery voltage
					Stop	0
45 (L/R)	Ground	Lifting motor (front) upward output	Out- put	Seat lifting (front)	Operate (upward)	Battery voltage
					Stop	0
48 (B)	Ground	Ground (power)	—	—	—	0

*: Not in the sleep mode.

Wiring Diagram - POWER SEAT SYSTEM FOR DRIVER SIDE (WITHOUT AUTO-

DRIVER SEAT CONTROL UNIT (WITHOUT AUTOMATIC DRIVE POSITIONER)

< ECU DIAGNOSIS INFORMATION >

MATIC DRIVE POSITIONER) -

INFOID:000000008158164

For connector terminal arrangements, harness layouts, and alphabets in a  (option abbreviation; if not described in wiring diagram), refer to [GI-12, "Connector Information"](#).

POWER SEAT FOR DRIVER SIDE (WITHOUT AUTOMATIC DRIVE POSITIONER)

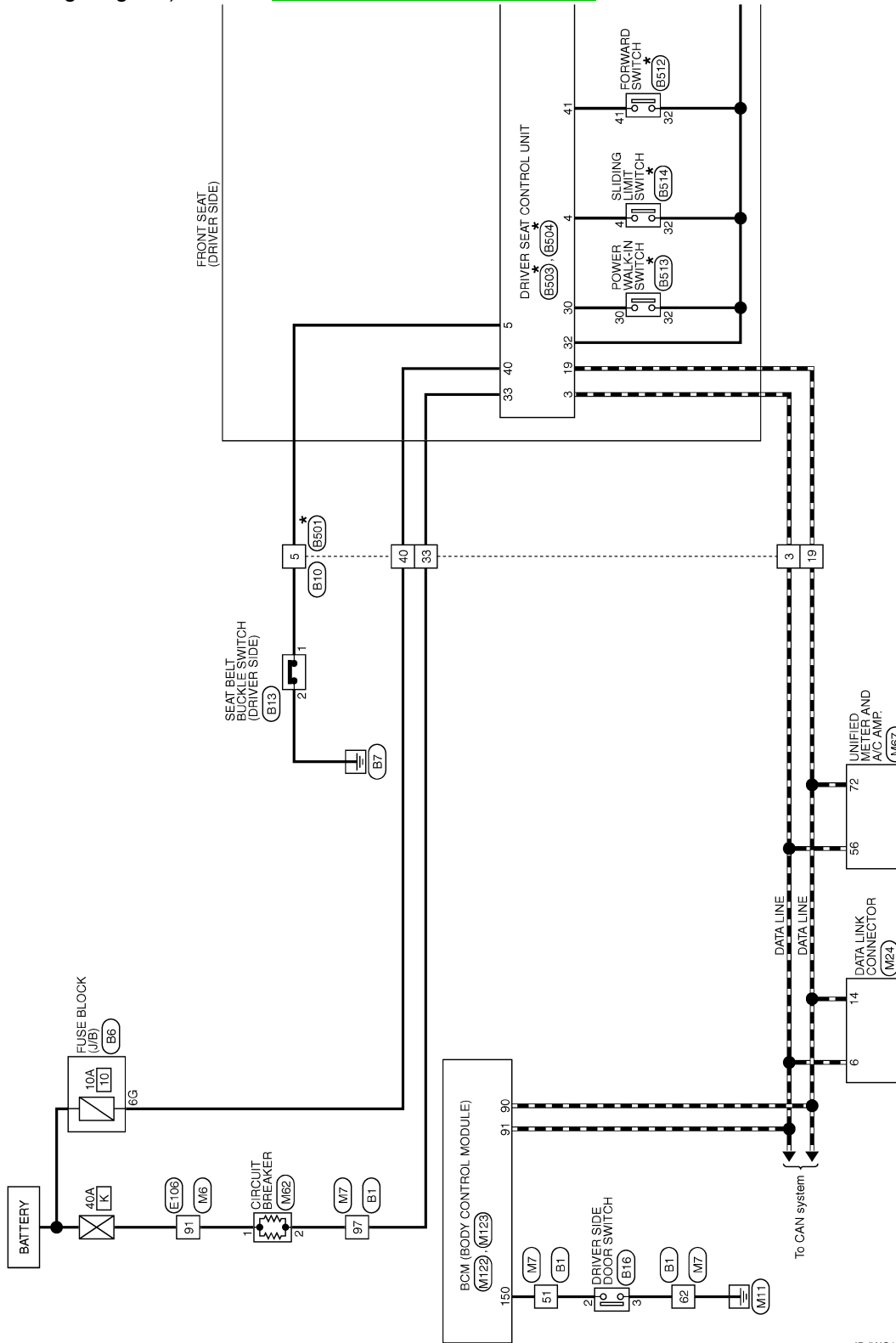

*: This connector is not shown in "Harness Layout".

2012/03/05

JR,JWC0519GB

A
B
C
D
E
F
G
H
I
SE
K
L
M
N
O
P

DRIVER SEAT CONTROL UNIT (WITHOUT AUTOMATIC DRIVE POSITIONER)

< ECU DIAGNOSIS INFORMATION >

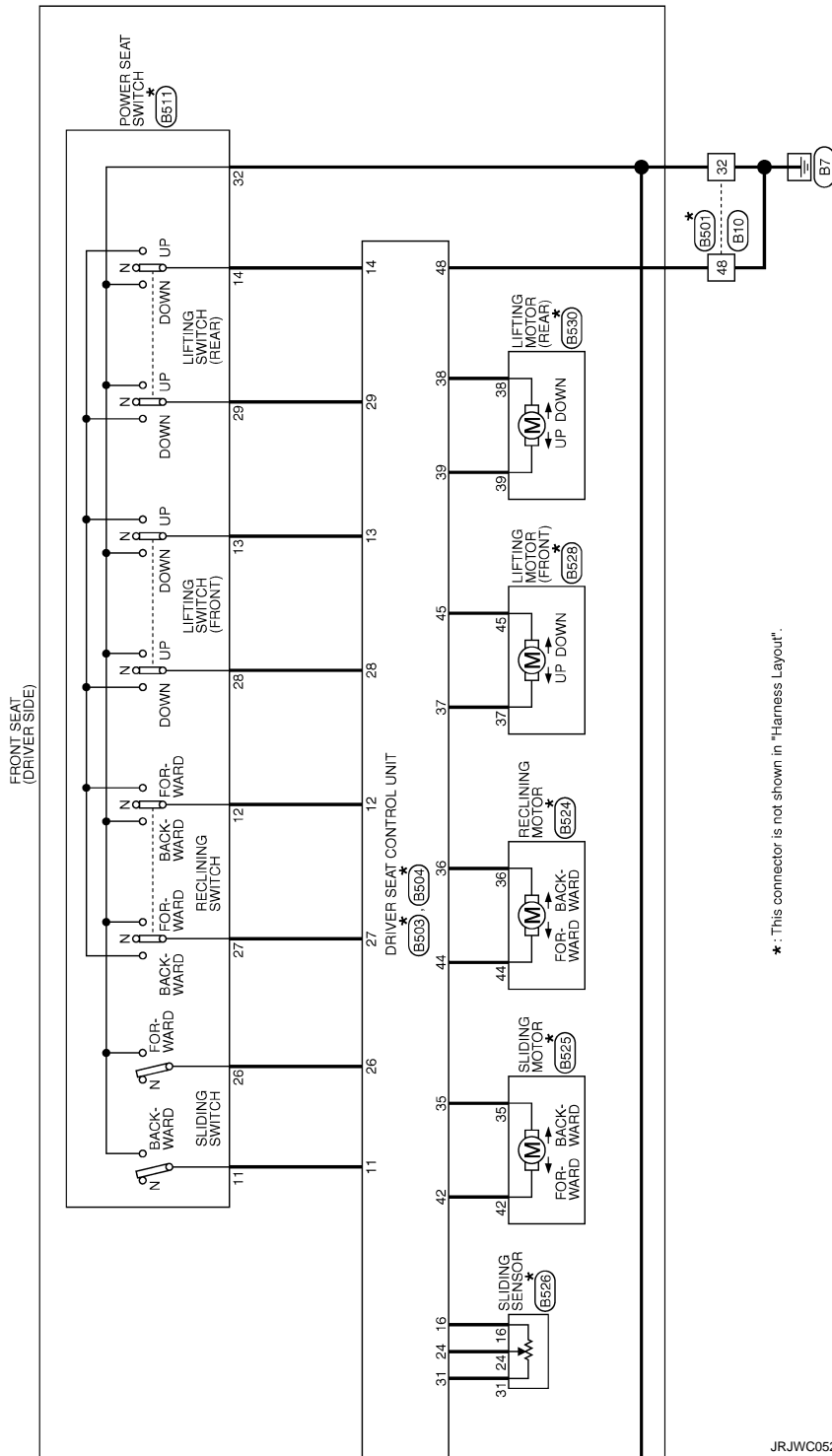

*: This connector is not shown in "Harness Layout".

JRJWC0520GB

INFOID:000000008158165

Fail-Safe

The fail-safe mode may be activated if the following symptoms are observed.

DRIVER SEAT CONTROL UNIT (WITHOUT AUTOMATIC DRIVE POSITIONER)

< ECU DIAGNOSIS INFORMATION >

Operating in fail-safe mode	Malfunction Item	Related DTC	Diagnosis
Only manual functions operate normally.	CAN communication*1	U1000	With ADP: ADP-48, "DTC Logic" Without ADP: SE-34, "DTC Logic"
	Tilt sensor	B2118	ADP-53, "DTC Logic"
	Telescopic sensor	B2119	ADP-56, "DTC Logic"
	Detent switch	B2126	ADP-59, "DTC Logic"
	Parking brake switch	B2127	ADP-61, "DTC Logic"
Only manual functions, except door mirror, operate normally.	UART communication	B2128	ADP-63, "DTC Logic"
Only manual functions, except seat sliding, operate normally.	Seat sliding output*1	B2112	SE-35, "DTC Logic"
Only manual functions, except seat reclining, operate normally.	Seat reclining output*1	B2113	SE-37, "DTC Logic"

*1: Driver seat without automatic driver positioner system display.

DTC Index

INFOID:000000008158166

CONSULT display	Timing*1		Item	Reference page
	Current malfunction	Previous malfunction		
CAN COMM CIRCUIT*2 [U1000]	0	1-39	CAN communication	With ADP: ADP-48, "DTC Logic" Without ADP: SE-34, "DTC Logic"
SEAT SLIDE*2 [B2112]	0	1-39	Seat slide motor output	With ADP: ADP-49, "DTC Logic" Without ADP: SE-35, "DTC Logic"
SEAT RECLINING*2 [B2113]	0	1-39	Seat reclining motor output	SE-37, "DTC Logic"
TILT SENSOR [B2118]	0	1-39	Tilt sensor input	ADP-53, "DTC Logic"
TELESCO SENSOR [B2119]	0	1-39	Telescopic sensor input	ADP-56, "DTC Logic"
DETENT SW [B2126]	0	1-39	Detention switch condition	ADP-59, "DTC Logic"
PARKING BRAKE [B2127]	0	1-39	Parking brake switch condition	ADP-61, "DTC Logic"
UART COMM [B2128]	0	1-39	UART communication	ADP-63, "DTC Logic"

*1:

DRIVER SEAT CONTROL UNIT (WITHOUT AUTOMATIC DRIVE POSITIONER)

< ECU DIAGNOSIS INFORMATION >

- 0: Current malfunction is present
 - 1-39: Displayed if any previous malfunction is present when current condition is normal. The numeral value increases by one at each IGN ON to OFF cycle from 1 to 39. The counter remains at 39 even if the number of cycles exceeds it. However, the counter is reset to 1 if any malfunction is detected again, the normal operation is resumed and the ignition switch is turned from OFF to ON.
- *2: Driver seat without automatic driver positioner system display.

PASSENGER SEAT CONTROL UNIT

< ECU DIAGNOSIS INFORMATION >

PASSENGER SEAT CONTROL UNIT

Reference Value

INFOID:000000008158167

TERMINAL LAYOUT

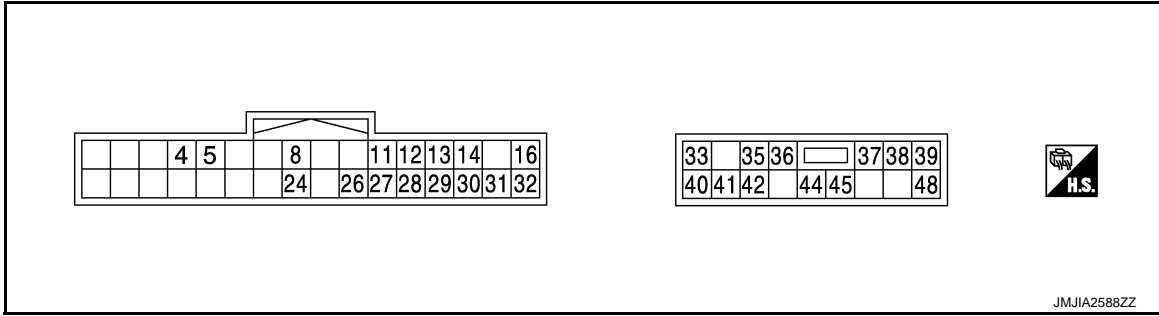

PHYSICAL VALUES

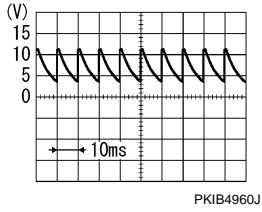
Terminal No. (Wire color)		Description		Condition	Voltage (V) (Approx.)
(+)	(-)	Signal name	Input/ Output		
4 (O/B)	Ground	Sliding limit switch signal	Input	Seat sliding front edge	0
				Other than above*	5
5 (L)	Ground	Seat belt buckle switch signal (passenger side)	Input	Ignition switch OFF and seat belt fastened*	5
				Ignition switch ON and seat belt released	Battery voltage
				Other than above	0
8 (LG)	Ground	Passenger side door switch signal	Input	Passenger door	Open 0
				Closed	
11 (BR)	Ground	Sliding switch backward signal	Input	Sliding switch	Operate (backward) 0
				Release	Battery voltage
12 (SB)	Ground	Reclining switch backward signal	Input	Reclining switch	Operate (backward) 0
				Release	Battery voltage
13 (LG/R)	Ground	Lifting switch (front) downward signal	Input	Lifting switch (front)	Operate (downward) 0
				Release	Battery voltage
14 (G/B)	Ground	Lifting switch (rear) downward signal	Input	Lifting switch (rear)	Operate (downward) 0
				Release	Battery voltage
16 (O)	Ground	Sensor power supply	Output	—	Battery voltage

A
B
C
D
E
F
G
H
I
SE
K
L
M
N
O
P

PASSENGER SEAT CONTROL UNIT

< ECU DIAGNOSIS INFORMATION >

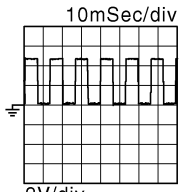
Terminal No. (Wire color)		Description		Condition	Voltage (V) (Approx.)	
(+)	(-)	Signal name	Input/ Output			
24 (R)	Ground	Sliding sensor signal	Input	Seat sliding	Operate	 2V/div JMJA0119ZZ
					Stop	
26 (Y)	Ground	Sliding switch forward signal	Input	Sliding switch	Operate (forward)	0
					Release	Battery voltage
27 (R/G)	Ground	Reclining switch forward signal	Input	Reclining switch	Operate (forward)	0
					Release	Battery voltage
28 (W/B)	Ground	Lifting switch (front) upward signal	Input	Seat lifting switch (front)	Operate (upward)	0
					Release	Battery voltage
29 (P/L)	Ground	Lifting switch (rear) upward signal	Input	Seat lifting switch (rear)	Operate (upward)	0
					Release	Battery voltage
30 (P)	Ground	Power walk-in switch signal	Input	Power walk-in switch	Pressed	0
					Other than above	Battery voltage
31 (GR)	Ground	Sensor ground	—	—	0	
32 (B/W)	Ground	Ground (signal)	—	—	0	
33 (R)	Ground	Power source (C/B)	Input	—	Battery voltage	
35 (W/R)	Ground	Sliding motor forward output	Output	Seat sliding	Operate (forward)	Battery voltage
					Release	0
36 (W/L) ^{*1} (G/Y) ^{*2}	Ground	Reclining motor forward output signal	Output	Seat reclining	Operate (forward)	Battery voltage
					Release	0
37 (LG/R) ^{*1} (G/W) ^{*2}	Ground	Lifting motor (front) downward output	Output	Seat lifting (front)	Operate (downward)	Battery voltage
					Stop	0
38 (P/L) ^{*1} (L/Y) ^{*2}	Ground	Lifting motor (rear) upward output	Output	Seat lifting (rear)	Operate (upward)	Battery voltage
					Stop	0
39 (G/B) ^{*1} (R/B) ^{*2}	Ground	Lifting motor (rear) downward output	Output	Seat lifting (rear)	Operate (downward)	Battery voltage
					Stop	0
40 (R/W)	Ground	Power source (Fuse)	Input	—	Battery voltage	
41 (Y/G)	Ground	Forward switch signal	Input	Seatback is folded down	0	
				Other than above*	5	

PASSENGER SEAT CONTROL UNIT

< ECU DIAGNOSIS INFORMATION >

Terminal No. (Wire color)		Description		Condition	Voltage (V) (Approx.)
(+)	(-)	Signal name	Input/ Output		
42 (W)	Ground	Sliding motor back- ward output	Output	Seat sliding	Battery voltage
				Operate (backward)	0
44 (L) ^{*1} (P) ^{*2}	Ground	Reclining motor backward output	Output	Seat reclining	Battery voltage
				Operate (backward)	0
45 (W/B) ^{*1} (L/R) ^{*2}	Ground	Lifting motor (front) upward output	Output	Seat lifting (front)	Battery voltage
				Operate (upward)	0
48 (B)	Ground	Ground (power)	—	—	0

*: Not in the sleep mode.

*1: With climate controlled seat.

*2: Without climate controlled seat.

A
B
C
D
E
F
G
H
I
K
L
M
N
O
P

SE

PASSENGER SEAT CONTROL UNIT

< ECU DIAGNOSIS INFORMATION >

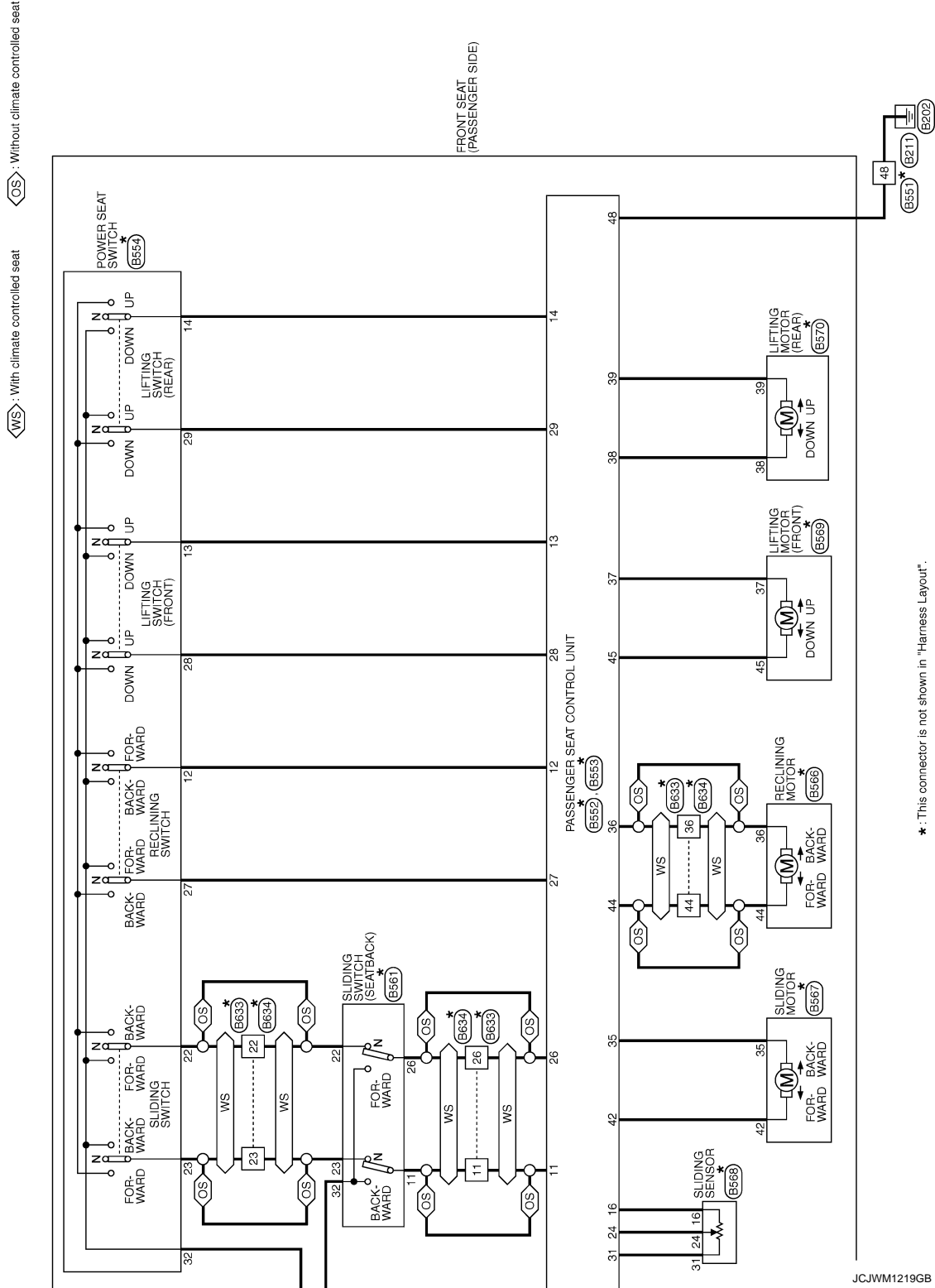

A
B
C
D
E
F
G
H
I
SE
K
L
M
N
O
P

HEATED SEAT CONTROL UNIT

< ECU DIAGNOSIS INFORMATION >

HEATED SEAT CONTROL UNIT

Reference Value

INFOID:000000008158169

TERMINAL LAYOUT

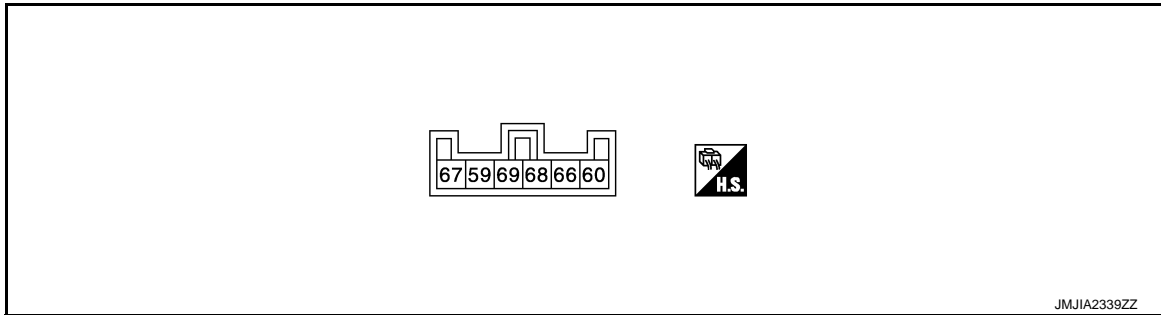

PHYSICAL VALUES

Terminal No. (Wire color)		Description		Condition	Voltage (V) (Approx.)
(+)	(-)	Signal name	Input/ Output		
48 (B)	Ground	Ground	–	Ignition switch ON	0
60 (Y)	Ground	IGN power supply	Input	Ignition switch	OFF or ACC ON Battery voltage
66 (B) ^{*1} (B/Y) ^{*2}	Ground	Heated seat operation signal	Input	Heated seat	Operate Other than above Battery voltage 0
67 (W)	Ground	Heated seat switch signal	Input	Heated seat switch	OFF 1 (Min. temperature) 2 3 4 5 6 (Max. temperature) 12.24 12.33 12.49 12.63 12.76 12.90
68 (R/W)	Ground	Seat cushion heater power supply	Output	Heated seat	Operate Other than above 0 – Battery voltage* 0
69 (R)	Ground	Heat sensor signal	Input	Heated seat switch	OFF 1 (Min. temperature) 2 3 4 5 6 (Max. temperature) 0 10.87 – 11.02* 10.93 – 11.07* 11.04 – 11.17* 11.13 – 11.26* 11.22 – 11.34* 11.31 – 11.43*

*: Voltage is repeated within the value shown as per the following list depending on heater unit temperature.

*1: With side support.

*2: Without side support.

HEATED SEAT CONTROL UNIT

< ECU DIAGNOSIS INFORMATION >

Wiring Diagram - HEATED SEAT SYSTEM (WITH M/T) -

INFOID:000000008158170

For connector terminal arrangements, harness layouts, and alphabets in a  (option abbreviation; if not described in wiring diagram), refer to [GI-12, "Connector Information"](#).

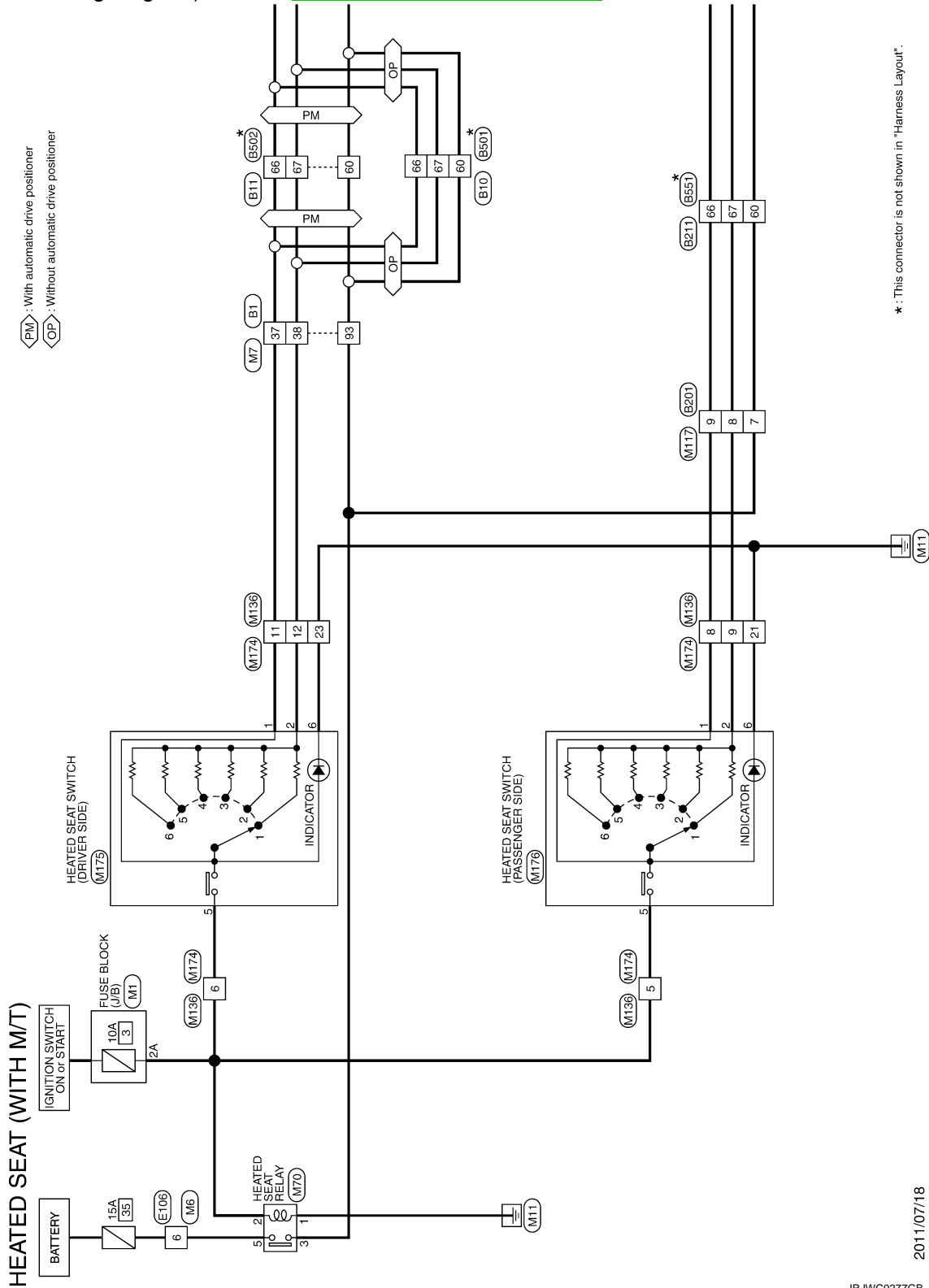

2011/07/18

JR.JWC0277GB

A
B
C
D
E
F
G
H
I
SE
K
L
M
N
O
P

HEATED SEAT CONTROL UNIT

< ECU DIAGNOSIS INFORMATION >

PM : With automatic drive positioner
OP : Without automatic drive positioner

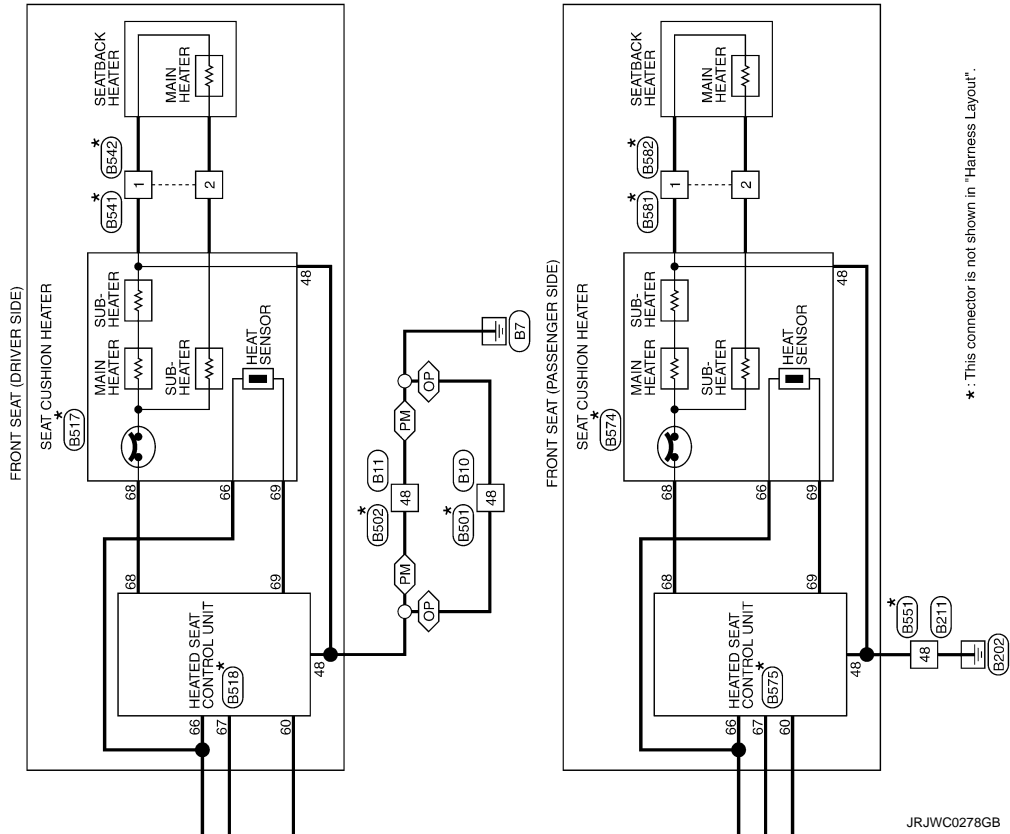

JRJWC0278GB

HEATED SEAT CONTROL UNIT

< ECU DIAGNOSIS INFORMATION >

Wiring Diagram - HEATED SEAT SYSTEM (WITH A/T) -

INFOID:000000008158171

For connector terminal arrangements, harness layouts, and alphabets in a  (option abbreviation; if not described in wiring diagram), refer to [GI-12, "Connector Information"](#).

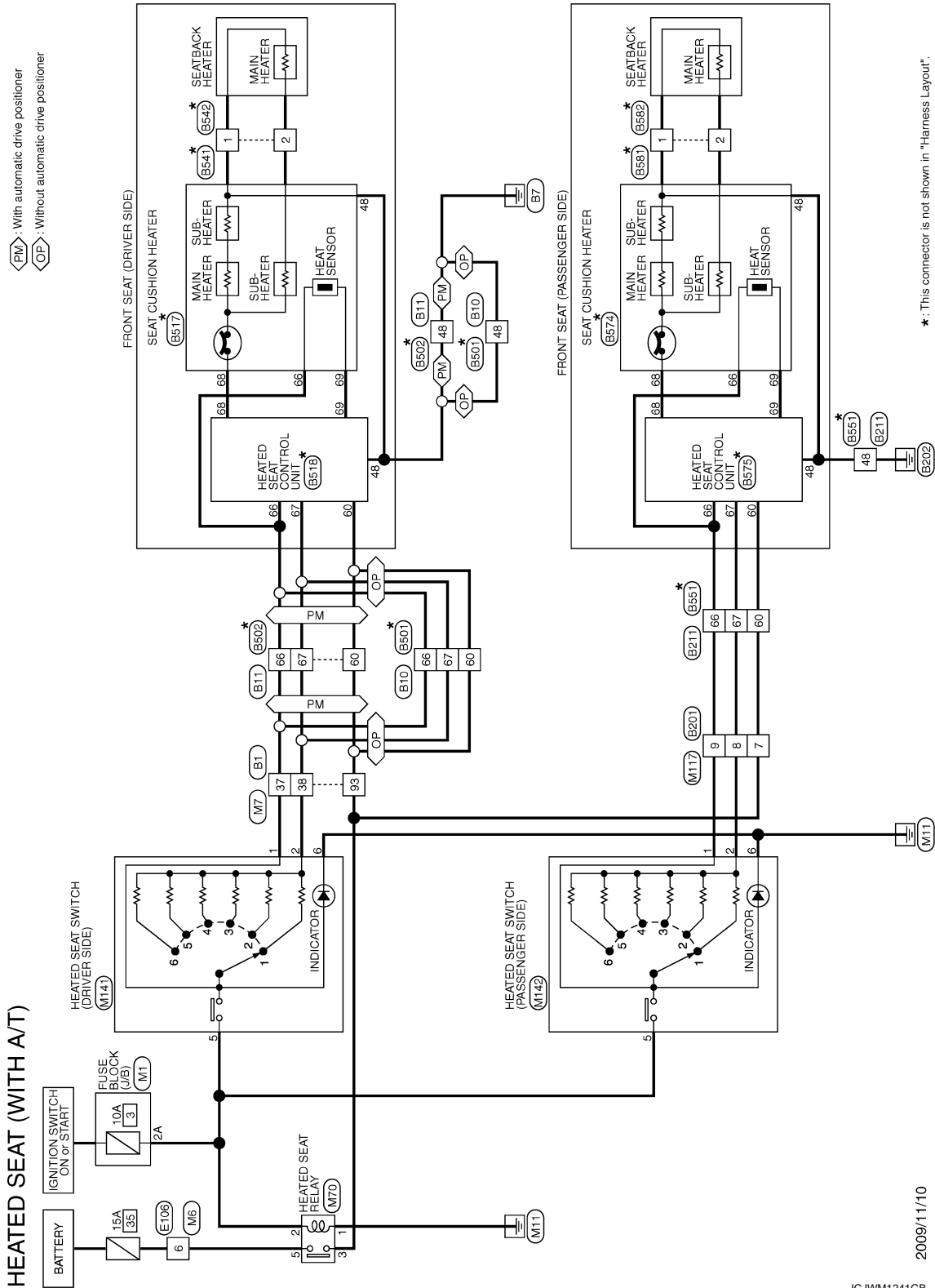

2009/11/10

JCJWM1241GB

A
B
C
D
E
F
G
H
I
SE
K
L
M
N
O
P

CLIMATE CONTROLLED SEAT CONTROL UNIT

< ECU DIAGNOSIS INFORMATION >

CLIMATE CONTROLLED SEAT CONTROL UNIT

Reference Value

INFOID:000000008158172

TERMINAL LAYOUT

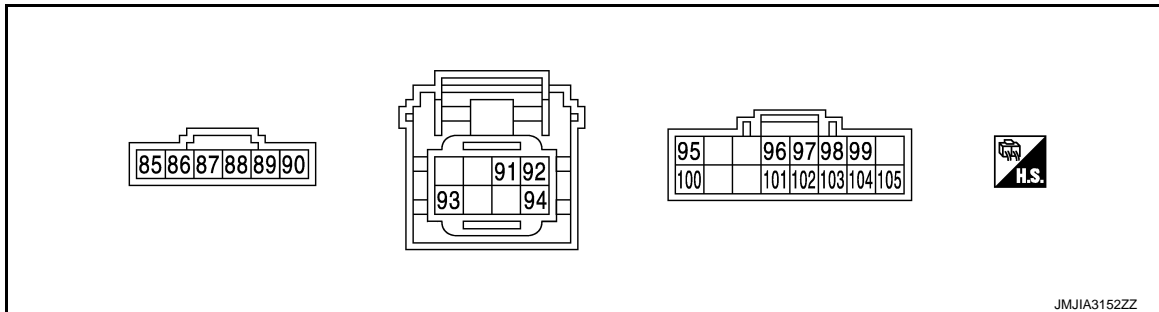

PHYSICAL VALUES

Terminal No.		Wire color	Description		Condition		Value (Approx.)
+	-		Signal name	Input/Output			
85	Ground	G	Seatback thermal electric device COOL signal	Output	Climate controlled seat switch	HEAT or COOL	0 - Battery voltage*
						OFF	0
86	Ground	G/W	Seat cushion thermal electric device COOL-signal	Output	Climate controlled seat switch	HEAT or COOL	0 - Battery voltage*
						OFF	0
87	Ground	G/B	Seat cushion thermal electric device HEAT signal	Output	Climate controlled seat switch	HEAT or COOL	0 - Battery voltage*
						OFF	0
88	Ground	G/R	Seatback thermal electric device HEAT signal	Output	Climate controlled seat switch	HEAT or COOL	0 - Battery voltage*
						OFF	0
89	Ground	R	Ignition switch power supply	Input	Ignition switch ON		Battery voltage
90	Ground	L	Ground	—	—		0
91	Ground	Y	HEAT switch signal	Input	Climate controlled seat switch	HI HEAT	2.6 - 4.2
						MID HEAT	1.6 - 2.5
						LO HEAT	0.8 - 1.5
						OFF	0
92	Ground	W	COOL switch signal	Input	Climate controlled seat switch	HI COOL	2.6 - 4.2
						MID COOL	1.6 - 2.5
						LO COOL	0.8 - 1.5
						OFF	0
93	Ground	W/B	Ignition switch power supply	Input	Ignition switch ON		Battery voltage
94	Ground	W/R	Climate controlled seat switch power supply	Output	Ignition switch ON		Battery voltage
95	Ground	R/L	HEAT switch indicator signal	Output	Climate controlled seat switch	HEAT	Battery voltage
						OFF	0

CLIMATE CONTROLLED SEAT CONTROL UNIT

< ECU DIAGNOSIS INFORMATION >

Terminal No.		Wire color	Description		Condition		Value (Approx.)
+	-		Signal name	Input/Output			
96	Ground	R/W	Seatback blower motor speed control signal	Output	Climate controlled seat switch	HEAT	7.5 - 8
						HI COOL	12
						MID COOL	8
						LO COOL	6.5
97	Ground	R	seat cushion blower motor speed control signal	Output	Climate controlled seat switch	HEAT	7.5 - 8
						HI COOL	12
						MID COOL	8
						LO COOL	6.5
98	Ground	L	Blower motor ground	—	—	0	
99	Ground	L/W	Statback blower motor power supply	Output	Climate controlled seat switch	HEAT or COOL	Battery voltage
					Other than the above		0
100	Ground	GR	COOL switch indicator signal	Output	Climate controlled seat switch	COOL	Battery voltage
						OFF	0
101	Ground	GR/R	Seat cushion blower motor power supply	Output	Climate controlled seat switch	HEAT or COOL	Battery voltage
					Other than the above		0
102	Ground	V	Seat cushion thermal electric device sensor ground	—	Ignition switch ON	0	
103	Ground	BR	Seat cushion thermal electric device sensor signal	Input	Climate controlled seat operated	1 - 5	
104	Ground	V/W	Seatback thermal electric device sensor ground	—	Ignition switch ON	0	
105	Ground	LG	Seatback thermal electric device sensor signal	Input	Climate controlled seat operated	1 - 5	

*:It changes between battery voltage or 0V

NOTE:

- Measure the value on the condition that the battery voltage is 14 V
- Wait 1 minute or more after thermal electric device is activated, and then start the measurement

A
B
C
D
E
F
G
H
I
SE
K
L
M
N
O
P

CLIMATE CONTROLLED SEAT CONTROL UNIT

< ECU DIAGNOSIS INFORMATION >

* : This connector is not shown in "Harness Layout".

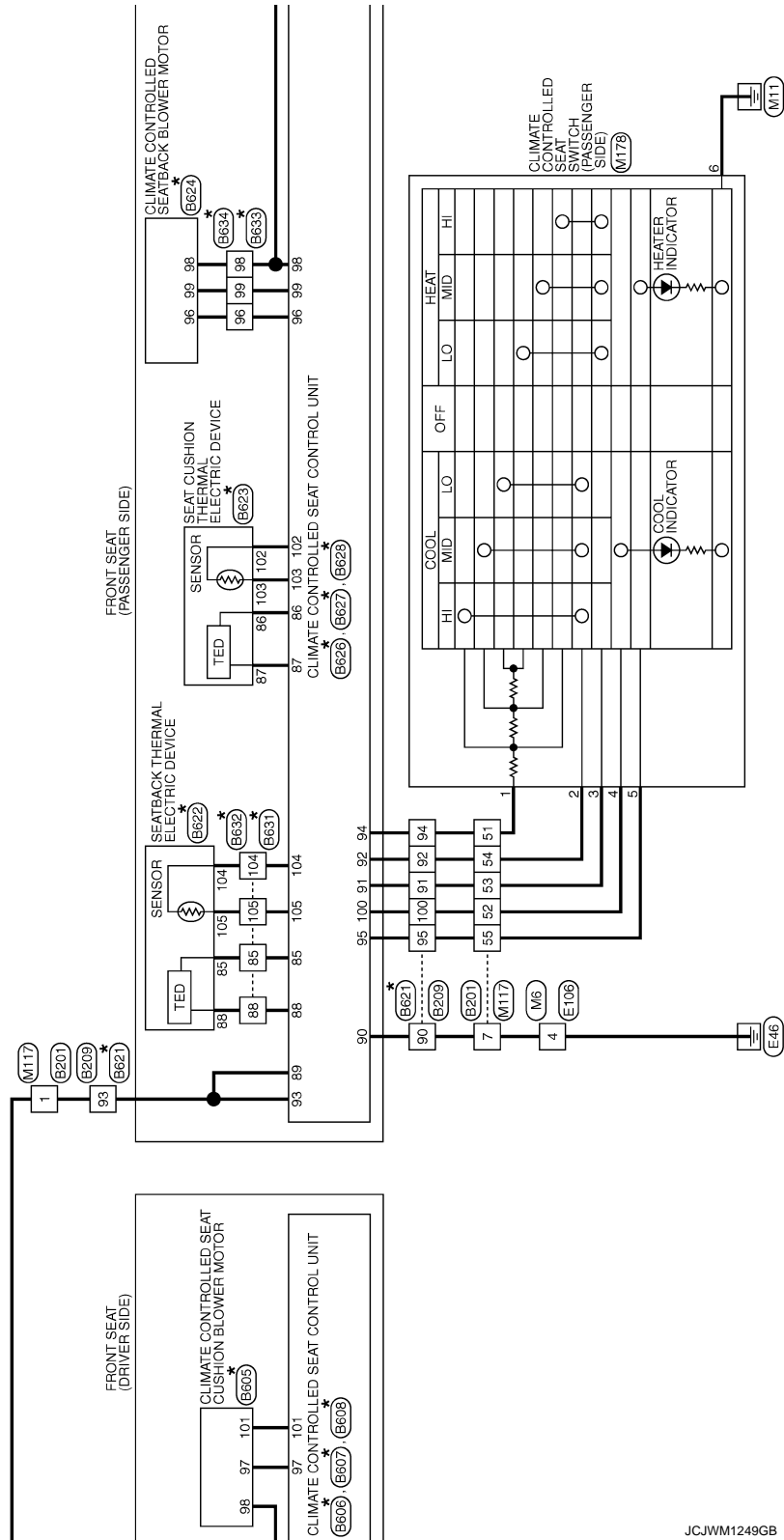

JCJWM1249GB

A
B
C
D
E
F
G
H
I
SE
K
L
M
N
O
P

CLIMATE CONTROLLED SEAT CONTROL UNIT

< ECU DIAGNOSIS INFORMATION >

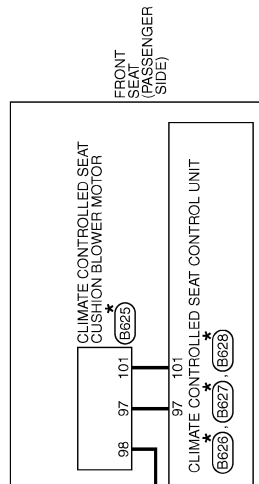

*: This connector is not shown in "Harness Layout".

JCJWM1250GB

INFOID:000000008158174

Fail-safe

- Climate controlled seat control unit equips fail-safe function.
- When a malfunction occurs in the systems shown below, climate controlled seat control unit stops output.

CLIMATE CONTROLLED SEAT CONTROL UNIT

< ECU DIAGNOSIS INFORMATION >

Malfunction	Malfunctioning condition	A
<p>The temperature difference between the seatback thermal electric device and seat cushion thermal electric device is more than 30°C</p>	<ul style="list-style-type: none"> • When it detects for 4 seconds that the temperature difference between the seatback thermal electric device and seat cushion thermal electric device is more than 30°, it stops the output to the thermal electric device, activates the climate controlled seat blower motor at the maximum position, and sends the external airflow for 30 seconds • If the temperature difference is still more than 30°C after 30 seconds pass, it stops all output and enters the system OFF condition • When the temperature difference between seatback thermal electric device and seat cushion thermal electric device becomes less than 20°C, the system recovers automatically • If it detects that the temperature difference is more than 30°C after the automatic system recovery, it immediately stops all output and enters the system OFF condition <p>NOTE: When the switch operation is performed before entering the system OFF condition, the fail-safe mode is reset.</p>	<p>B</p> <p>C</p> <p>D</p> <p>E</p>
<p>The temperature of thermal electric device is more than 110°C in the HEAT mode (any thermal electric device in the seatback or seat cushion)</p>	<ul style="list-style-type: none"> • When it detects for 4 seconds that the temperature of the thermal electric device is more than 110°C, it stops the output to the thermal electric device, activates the climate controlled seat blower motor at the maximum position, and sends the external airflow for 30 seconds • If the temperature does not become less than 105°C after 30 seconds pass, it stops all output and enters the system OFF condition • When the temperature of the thermal electric device becomes less than 105°C, the system recovers automatically • If it detects that the temperature of the thermal electric device is more than 110°C after the automatic system recovery, it immediately stops all output and enters the system OFF condition 	<p>F</p> <p>G</p> <p>H</p>
<p>The temperature of the thermal electric device is more than 45°C in the COOL mode (any thermal electric device in the seatback or seat cushion)</p>	<ul style="list-style-type: none"> • When it detects for 4 seconds that the temperature of the thermal electric device is more than 45°C and less than 70°C, it starts the temperature monitoring of the thermal electric device at 3 second intervals • While monitoring, if it detects that the temperature continuously rises 2°C or more 4 times or reaches 70°C or more, it stops all output and enters the system OFF condition • If it detects other results of monitoring, it continues activating in the COOL mode 	<p>I</p> <p style="background-color: black; color: white; text-align: center; padding: 2px;">SE</p>
<p>Thermal electric device sensor open circuit (in either the back and the cushion TED)</p>	<ul style="list-style-type: none"> • When it detects for 4 seconds that the thermal electric device sensor is an open circuit, it stops all output and enters the system OFF condition 	<p>K</p>
<p>Climate controlled seat blower motor system open circuit (in either the back and the cushion blower)</p>	<ul style="list-style-type: none"> • When it detects for 2 seconds that climate controlled seat blower motor is an open circuit while the climate controlled seat is being activated, and the battery status has been stable for the same 2 second period. it stops output to the thermal electric device • When it detects for 10 seconds that the climate controlled seat blower motor is an open circuit while the climate controlled seat is being activated, and the battery status has been stable for the same 10second period. it stops all output and enters the system OFF condition <p>NOTE: After detecting the climate seat blower motor system open circuit for 2 seconds, the system recovers automatically if the activation of the climate controlled seat blower motor is detected for 1 second or more.</p>	<p>L</p> <p>M</p> <p>N</p>
<p>Switch input out of the specified range (either heat input or cool input)</p>	<ul style="list-style-type: none"> • When it detects for 4 seconds that the rotary switch input is less than 30% of the vehicle battery voltage, it stops all output and enters the system OFF condition • When the switch input returns to a value within the specified range, the system recovers automatically 	<p>O</p> <p>P</p>

CLIMATE CONTROLLED SEAT CONTROL UNIT

< ECU DIAGNOSIS INFORMATION >

Malfunction	Malfunctioning condition
HEAT or COOL switch input out of the specified range	<ul style="list-style-type: none">• During the standby mode, heating or cooling states, if the rotary switch input is 6% or less of the vehicle battery voltage, it stops all output and enters the system OFF condition• When the switch input returns to a value within the specified range, the system recovers automatically
System voltage out of range	<ul style="list-style-type: none">• If the system voltage at the climate controlled seat control unit falls outside of the 8.5 to 16.5 V operating range, it stops all output after a 500ms time period.• When the system voltage returns to the normal operating range (10.5-15.5V with a 500ms hysteresis), the system recovers automatically.

*: System voltage is the voltage between the climate controlled seat control unit power source and ground.

NOTE:

When the ignition status changes to OFF during the fail-safe mode, the control unit shall enter the OFF condition. If the ignition is turned ON, the system shall return to the standby mode. If the system enters in the fail-safe mode again after performing ignition cycle, start the diagnosis.

ALL COMPONENTS OF POWER SEAT DO NOT OPERATE

< SYMPTOM DIAGNOSIS >

SYMPTOM DIAGNOSIS

ALL COMPONENTS OF POWER SEAT DO NOT OPERATE DRIVER SIDE

DRIVER SIDE : Diagnosis Procedure

INFOID:000000008158175

1. CHECK POWER SUPPLY CIRCUIT AND GROUND CIRCUIT

Check power supply circuit and ground circuit.

Refer to [SE-39, "DRIVER SEAT CONTROL UNIT : Diagnosis Procedure"](#).

Is the inspection result normal?

YES >> GO TO 2.

NO >> Repair or replace the malfunctioning parts.

2. CHECK POWER SEAT SWITCH GROUND CIRCUIT

Check power seat switch ground circuit.

Refer to [SE-67, "DRIVER SIDE : Diagnosis Procedure"](#).

Is the inspection result normal?

YES >> GO TO 3.

NO >> Repair or replace the malfunctioning parts.

3. CONFIRM THE OPERATION

Check the operation again.

Is the result normal?

YES >> Check intermittent incident. Refer to [GI-42, "Intermittent Incident"](#).

NO >> GO TO 1.

PASSENGER SIDE

PASSENGER SIDE : Diagnosis Procedure

INFOID:000000008158176

SE

1. CHECK POWER SUPPLY AND GROUND CIRCUIT

Check power supply and ground circuit.

Refer to [SE-39, "PASSENGER SEAT CONTROL UNIT : Diagnosis Procedure"](#).

Is the inspection result normal?

YES >> GO TO 2.

NO >> Repair or replace the malfunctioning parts.

2. CHECK POWER SEAT SWITCH GROUND CIRCUIT

Check power seat switch ground circuit.

Refer to [SE-67, "PASSENGER SIDE : Diagnosis Procedure"](#).

Is the inspection result normal?

YES >> GO TO 3.

NO >> Repair or replace the malfunctioning parts.

3. CONFIRM THE OPERATION

Check the operation again.

Is the result normal?

YES >> Check intermittent incident. Refer to [GI-42, "Intermittent Incident"](#).

NO >> GO TO 1.

POWER SEAT SWITCH (PASSENGER SIDE) DOES NOT OPERATE ANY COMPONENTS

< SYMPTOM DIAGNOSIS >

POWER SEAT SWITCH (PASSENGER SIDE) DOES NOT OPERATE ANY COMPONENTS

Diagnosis Procedure

INFOID:000000008158177

1. CHECK POWER SEAT SWITCH GROUND CIRCUIT

Check power seat switch ground circuit.

Refer to [SE-67, "PASSENGER SIDE : Diagnosis Procedure"](#).

Is the inspection result normal?

YES >> GO TO 2.

NO >> Repair or replace the malfunctioning parts.

2. CONFIRM THE OPERATION

Check the operation again.

Is the result normal?

YES >> Check intermittent incident. Refer to [GI-42, "Intermittent Incident"](#).

NO >> GO TO 1.

SLIDING FUNCTION DOES NOT OPERATE

< SYMPTOM DIAGNOSIS >

SLIDING FUNCTION DOES NOT OPERATE

DRIVER SIDE

DRIVER SIDE : Diagnosis Procedure

INFOID:000000008158178

1.CHECK SLIDING MECHANISM

Check for the following.

- Mechanism deformation or pinched foreign materials.
- Interference with other parts because of poor installation.

Is the inspection result normal?

YES >> GO TO 2.

NO >> Repair or replace the malfunctioning parts.

2.CHECK SLIDING SWITCH

Check sliding switch.

Refer to [SE-49, "DRIVER SIDE : Component Function Check"](#).

Is the inspection result normal?

YES >> GO TO 3.

NO >> Repair or replace the malfunctioning parts.

3.CHECK SLIDING MOTOR

Check sliding motor.

Refer to [SE-92, "DRIVER SIDE : Component Function Check"](#).

Is the inspection result normal?

YES >> GO TO 4.

NO >> Repair or replace the malfunctioning parts.

4.CONFIRM THE OPERATION

Check the operation again.

Is the result normal?

YES >> Check intermittent incident. Refer to [GI-42, "Intermittent Incident"](#).

NO >> GO TO 1.

PASSENGER SIDE

PASSENGER SIDE : Diagnosis Procedure

INFOID:000000008158179

1.CHECK SLIDING OPERATION

Check sliding operation.

Which sliding switch is malfunctioning?

Both sides>>GO TO 2.

Seatback side>>GO TO 4.

Power seat switch side>>GO TO 5.

2.CHECK SLIDING MECHANISM

Check for the following.

- Mechanism deformation or pinched foreign materials.
- Interference with other parts because of poor installation.

Is the inspection result normal?

YES >> GO TO 3.

NO >> Repair or replace the malfunctioning parts.

3.CHECK SLIDING MOTOR

Check sliding motor.

Refer to [SE-93, "PASSENGER SIDE : Component Function Check"](#).

Is the inspection result normal?

SLIDING FUNCTION DOES NOT OPERATE

< SYMPTOM DIAGNOSIS >

- YES >> GO TO 4.
- NO >> Repair or replace the malfunctioning parts.

4.CHECK SLIDING SWITCH (SEATBACK)

Check sliding switch (seatback).
Refer to [SE-52. "SEATBACK : Component Function Check"](#).

Is the inspection result normal?

- YES >> GO TO 6.
- NO >> Repair or replace the malfunctioning parts.

5.CHECK SLIDING SWITCH

Check sliding switch.
Refer to [SE-50. "PASSENGER SIDE : Component Function Check"](#).

Is the inspection result normal?

- YES >> GO TO 6.
- NO >> Repair or replace the malfunctioning parts.

6.CONFIRM THE OPERATION

Check the operation again.

Is the result normal?

- YES >> Check intermittent incident. Refer to [GI-42. "Intermittent Incident"](#).
- NO >> GO TO 1.

RECLINING FUNCTION DOES NOT OPERATE

< SYMPTOM DIAGNOSIS >

RECLINING FUNCTION DOES NOT OPERATE

DRIVER SIDE

DRIVER SIDE : Diagnosis Procedure

INFOID:000000008158180

1.CHECK RECLINING MECHANISM

Check for the following.

- Mechanism deformation or pinched foreign materials.
- Interference with other parts because of poor installation.

Is the inspection result normal?

YES >> GO TO 2.

NO >> Repair or replace the malfunctioning parts.

2.CHECK RECLINING SWITCH

Check reclining switch.

Refer to [SE-55, "DRIVER SIDE : Component Function Check"](#).

Is the inspection result normal?

YES >> GO TO 3.

NO >> Repair or replace the malfunctioning parts.

3.CHECK FORWARD SWITCH

Check forward switch.

Refer to [SE-69, "DRIVER SIDE : Component Function Check"](#).

Is the inspection result normal?

YES >> GO TO 4.

NO >> Repair or replace the malfunctioning parts.

4.CHECK RECLINING MOTOR

Check reclining motor.

Refer to [SE-95, "DRIVER SIDE : Component Function Check"](#).

Is the inspection result normal?

YES >> GO TO 5.

NO >> Repair or replace the malfunctioning parts.

5.CONFIRM THE OPERATION

Check the operation again.

Is the result normal?

YES >> Check intermittent incident. Refer to [GI-42, "Intermittent Incident"](#).

NO >> GO TO 1.

PASSENGER SIDE

PASSENGER SIDE : Diagnosis Procedure

INFOID:000000008158181

1.CHECK RECLINING MECHANISM

Check for the following.

- Mechanism deformation or pinched foreign materials.
- Interference with other parts because of poor installation.

Is the inspection result normal?

YES >> GO TO 2.

NO >> Repair or replace the malfunctioning parts.

2.CHECK RECLINING SWITCH

Check reclining switch.

Refer to [SE-56, "PASSENGER SIDE : Component Function Check"](#).

Is the inspection result normal?

A

B

C

D

E

F

G

H

I

SE

K

L

M

N

O

P

RECLINING FUNCTION DOES NOT OPERATE

< SYMPTOM DIAGNOSIS >

YES >> GO TO 3.

NO >> Repair or replace the malfunctioning parts.

3.CHECK FORWARD SWITCH

Check forward switch.

Refer to [SE-70. "PASSENGER SIDE : Component Function Check"](#).

Is the inspection result normal?

YES >> GO TO 4.

NO >> Repair or replace the malfunctioning parts.

4.CHECK RECLINING MOTOR

Check reclining motor.

Refer to [SE-96. "PASSENGER SIDE : Component Function Check"](#).

Is the inspection result normal?

YES >> GO TO 5.

NO >> Repair or replace the malfunctioning parts.

5.CONFIRM THE OPERATION

Check the operation again.

Is the result normal?

YES >> Check intermittent incident. Refer to [GI-42. "Intermittent Incident"](#).

NO >> GO TO 1.

LIFTING FUNCTION DOES NOT OPERATE

< SYMPTOM DIAGNOSIS >

LIFTING FUNCTION DOES NOT OPERATE FRONT

FRONT : Diagnosis Procedure

INFOID:000000008158182

1.CHECK LIFTING MECHANISM

Check for the following.

- Mechanism deformation or pinched foreign materials.
- Interference with other parts because of poor installation.

Is the inspection result normal?

YES >> GO TO 2.

NO >> Repair or replace the malfunctioning parts.

2.CHECK LIFTING SWITCH (FRONT)

Check lifting switch (front).

- Driver side: Refer to [SE-59, "DRIVER SIDE : Component Function Check"](#).
- Passenger side: Refer to [SE-60, "PASSENGER SIDE : Component Function Check"](#).

Is the inspection result normal?

YES >> GO TO 3.

NO >> Repair or replace the malfunctioning parts.

3.CHECK LIFTING MOTOR (FRONT)

Check lifting motor (front).

- Driver side: Refer to [SE-97, "DRIVER SIDE : Component Function Check"](#).
- Passenger side: Refer to [SE-98, "PASSENGER SIDE : Component Function Check"](#).

Is the inspection result normal?

YES >> GO TO 4.

NO >> Repair or replace the malfunctioning parts.

4.CONFIRM THE OPERATION

Check the operation again.

Is the result normal?

YES >> Check intermittent incident. Refer to [GI-42, "Intermittent Incident"](#).

NO >> GO TO 1.

REAR

REAR : Diagnosis Procedure

INFOID:000000008158183

1.CHECK LIFTING MECHANISM

Check for the following.

- Mechanism deformation or pinched foreign materials.
- Interference with other parts because of poor installation.

Is the inspection result normal?

YES >> GO TO 2.

NO >> Repair or replace the malfunctioning parts.

2.CHECK LIFTING SWITCH (REAR)

Check lifting switch (rear).

- Driver side: Refer to [SE-63, "DRIVER SIDE : Component Function Check"](#).
- Passenger side: Refer to [SE-64, "PASSENGER SIDE : Component Function Check"](#).

Is the inspection result normal?

YES >> GO TO 3.

NO >> Repair or replace the malfunctioning parts.

3.CHECK LIFTING MOTOR (REAR)

Check lifting motor (rear).

A
B
C
D
E
F
G
H
I
SE
K
L
M
N
O
P

LIFTING FUNCTION DOES NOT OPERATE

< SYMPTOM DIAGNOSIS >

- Driver side: Refer to [SE-99, "DRIVER SIDE : Component Function Check"](#).
- Passenger side: Refer to [SE-100, "PASSENGER SIDE : Component Function Check"](#).

Is the inspection result normal?

YES >> GO TO 4.

NO >> Repair or replace the malfunctioning parts.

4.CONFIRM THE OPERATION

Check the operation again.

Is the result normal?

YES >> Check intermittent incident. Refer to [GI-42, "Intermittent Incident"](#).

NO >> GO TO 1.

POWER WALK-IN FUNCTION DOES NOT OPERATE

< SYMPTOM DIAGNOSIS >

POWER WALK-IN FUNCTION DOES NOT OPERATE

DRIVER SIDE

DRIVER SIDE : Diagnosis Procedure

INFOID:000000008158184

1. CHECK SEAT SLIDING OPERATION

Check seat sliding operation.

Is the inspection result normal?

YES >> GO TO 2.

NO >> Refer to [SE-167, "DRIVER SIDE : Diagnosis Procedure"](#).

2. PERFORM INITIALIZATION PROCEDURE

1. Perform initialization procedure.

Refer to [SE-9, "SYSTEM INITIALIZATION : Special Repair Requirement"](#).

2. Check power walk-in function.

Refer to [SE-12, "POWER WALK-IN FUNCTION : System Description"](#).

Is the inspection result normal?

YES >> Power walk-in function is normal.

NO >> GO TO 3.

3. CHECK POWER WALK-IN SWITCH

Check power walk-in switch.

Refer to [SE-81, "DRIVER SIDE : Component Function Check"](#).

Is the inspection result normal?

YES >> GO TO 4.

NO >> Repair or replace the malfunctioning parts.

4. CHECK SEAT BELT BUCKLE SWITCH

Check seat belt buckle switch.

Refer to [SE-73, "DRIVER SIDE : Component Function Check"](#).

Is the inspection result normal?

YES >> GO TO 5.

NO >> Repair or replace the malfunctioning parts.

5. CHECK FORWARD SWITCH

Check forward switch.

Refer to [SE-69, "DRIVER SIDE : Component Function Check"](#).

Is the inspection result normal?

YES >> GO TO 6.

NO >> Repair or replace the malfunctioning parts.

6. CHECK SLIDING LIMIT SWITCH

Check sliding limit switch.

Refer to [SE-77, "DRIVER SIDE : Component Function Check"](#).

Is the inspection result normal?

YES >> GO TO 7.

NO >> Repair or replace the malfunctioning parts.

7. CHECK DRIVER SIDE DOOR SWITCH

Check driver side door switch.

Refer to [SE-85, "Component Function Check"](#)

Is the inspection result normal?

YES >> GO TO 8.

NO >> Repair or replace the malfunctioning parts.

8. CHECK SLIDING SENSOR

POWER WALK-IN FUNCTION DOES NOT OPERATE

< SYMPTOM DIAGNOSIS >

Check sliding sensor.

Refer to [SE-87, "DRIVER SIDE : Component Function Check"](#).

Is the inspection result normal?

YES >> GO TO 9.

NO >> Repair or replace the malfunctioning parts.

9.CONFIRM THE OPERATION

Check the operation again.

Refer to [SE-12, "POWER WALK-IN FUNCTION : System Description"](#).

Is the result normal?

YES >> Check intermittent incident. Refer to [GI-42, "Intermittent Incident"](#).

NO >> Replace driver seat control unit. Refer to [ADP-204, "Removal and Installation"](#).

PASSENGER SIDE

PASSENGER SIDE : Diagnosis Procedure

INFOID:000000008158185

1.CHECK SEAT SLIDING OPERATION

Check seat sliding operation.

Is the inspection result normal?

YES >> GO TO 2.

NO >> Refer to [SE-167, "PASSENGER SIDE : Diagnosis Procedure"](#).

2.PERFORM INITIALIZATION PROCEDURE

1. Perform initialization procedure.

Refer to [SE-9, "SYSTEM INITIALIZATION : Special Repair Requirement"](#).

2. Check power walk-in function.

Refer to [SE-12, "POWER WALK-IN FUNCTION : System Description"](#).

Is the inspection result normal?

YES >> Power walk-in function is normal.

NO >> GO TO 3.

3.CHECK POWER WALK-IN SWITCH

Check power walk-in switch.

Refer to [SE-82, "PASSENGER SIDE : Component Function Check"](#).

Is the inspection result normal?

YES >> GO TO 4.

NO >> Repair or replace the malfunctioning parts.

4.CHECK SEAT BELT BUCKLE SWITCH

Check seat belt buckle switch.

Refer to [SE-74, "PASSENGER SIDE : Component Function Check"](#).

Is the inspection result normal?

YES >> GO TO 5.

NO >> Repair or replace the malfunctioning parts.

5.CHECK FORWARD SWITCH

Check forward switch.

Refer to [SE-70, "PASSENGER SIDE : Component Function Check"](#).

Is the inspection result normal?

YES >> GO TO 6.

NO >> Repair or replace the malfunctioning parts.

6.CHECK SLIDING LIMIT SWITCH

Check sliding limit switch.

Refer to [SE-78, "PASSENGER SIDE : Component Function Check"](#).

Is the inspection result normal?

POWER WALK-IN FUNCTION DOES NOT OPERATE

< SYMPTOM DIAGNOSIS >

YES >> GO TO 7.

NO >> Repair or replace the malfunctioning parts.

7.CHECK PASSENGER SIDE DOOR SWITCH

Check passenger side door switch.

Refer to [SE-85. "Component Function Check"](#)

Is the inspection result normal?

YES >> GO TO 8.

NO >> Repair or replace the malfunctioning parts.

8.CHECK SLIDING SENSOR

Check sliding sensor.

Refer to [SE-87. "DRIVER SIDE : Component Function Check"](#).

Is the inspection result normal?

YES >> GO TO 9.

NO >> Repair or replace the malfunctioning parts.

9.CONFIRM THE OPERATION

Check the operation again.

Refer to [SE-12. "POWER WALK-IN FUNCTION : System Description"](#).

Is the result normal?

YES >> Check intermittent incident. Refer to [GI-42. "Intermittent Incident"](#).

NO >> Replace passenger seat control unit. Refer to [SE-225. "Removal and Installation"](#).

A
B
C
D
E
F
G
H
I
K
L
M
N
O
P

SE

HEATED SEAT DOES NOT OPERATE

< SYMPTOM DIAGNOSIS >

HEATED SEAT DOES NOT OPERATE BOTH SIDES

BOTH SIDES : Diagnosis Procedure

INFOID:000000008158186

1.CHECK HEATED SEAT SWITCH POWER SUPPLY

Check heated seat switch power supply.

Refer to [SE-43, "HEATED SEAT SWITCH : Diagnosis Procedure"](#).

Is the inspection result normal?

YES >> GO TO 2.

NO >> Repair or replace the malfunctioning parts.

2.CHECK HEATED SEAT RELAY

Check heated seat relay.

Refer to [SE-105, "Component Function Check"](#).

Is the inspection result normal?

YES >> GO TO 3.

NO >> Repair or replace the malfunctioning parts.

3.CHECK HEATED SEAT CONTROL UNIT POWER SUPPLY AND GROUND CIRCUIT

Check heated seat switch power supply and ground circuit.

Refer to [SE-41, "HEATED SEAT CONTROL UNIT : Diagnosis Procedure"](#).

Is the inspection result normal?

YES >> GO TO 4.

NO >> Repair or replace the malfunctioning parts.

4.CONFIRM THE OPERATION

Confirm the operation again.

Is the inspection result normal?

YES >> Check intermittent incident. Refer to [GI-42, "Intermittent Incident"](#).

NO >> GO TO 1.

DRIVER SIDE

DRIVER SIDE : Diagnosis Procedure

INFOID:000000008158187

1.CHECK HEATED SEAT SWITCH POWER SUPPLY

Check heated seat switch power supply.

Refer to [SE-43, "HEATED SEAT SWITCH : Diagnosis Procedure"](#).

Is the inspection result normal?

YES >> GO TO 2.

NO >> Repair or replace the malfunctioning parts.

2.CHECK HEATED SEAT CONTROL UNIT POWER SUPPLY AND GROUND CIRCUIT

Check heated seat switch power supply and ground circuit.

Refer to [SE-41, "HEATED SEAT CONTROL UNIT : Diagnosis Procedure"](#).

Is the inspection result normal?

YES >> GO TO 3.

NO >> Repair or replace the malfunctioning parts.

3.CHECK HEATED SEAT SWITCH

Check heated seat switch.

Refer to [SE-101, "DRIVER SIDE : Component Function Check"](#).

Is the inspection result normal?

YES >> GO TO 4.

NO >> Repair or replace the malfunctioning parts.

HEATED SEAT DOES NOT OPERATE

< SYMPTOM DIAGNOSIS >

4.CHECK SEAT CUSHION HEATER

Check seat cushion heater.

Refer to [SE-112, "DRIVER SIDE : Component Function Check"](#).

Is the inspection result normal?

YES >> GO TO 5.

NO >> Repair or replace the malfunctioning parts.

5.CONFIRM THE OPERATION

Confirm the operation again.

Is the inspection result normal?

YES >> Check intermittent incident. Refer to [GI-42, "Intermittent Incident"](#).

NO >> GO TO 1.

PASSENGER SIDE

PASSENGER SIDE : Diagnosis Procedure

INFOID:000000008158188

1.CHECK HEATED SEAT SWITCH POWER SUPPLY

Check heated seat switch power supply.

Refer to [SE-43, "HEATED SEAT SWITCH : Diagnosis Procedure"](#).

Is the inspection result normal?

YES >> GO TO 2.

NO >> Repair or replace the malfunctioning parts.

2.CHECK HEATED SEAT CONTROL UNIT POWER SUPPLY AND GROUND CIRCUIT

Check heated seat switch power supply and ground circuit.

Refer to [SE-41, "HEATED SEAT CONTROL UNIT : Diagnosis Procedure"](#).

Is the inspection result normal?

YES >> GO TO 3.

NO >> Repair or replace the malfunctioning parts.

3.CHECK HEATED SEAT SWITCH

Check heated seat switch.

Refer to [SE-102, "PASSENGER SIDE : Component Function Check"](#).

Is the inspection result normal?

YES >> GO TO 4.

NO >> Repair or replace the malfunctioning parts.

4.CHECK SEAT CUSHION HEATER

Check seat cushion heater.

Refer to [SE-113, "PASSENGER SIDE : Component Function Check"](#).

Is the inspection result normal?

YES >> GO TO 5.

NO >> Repair or replace the malfunctioning parts.

5.CONFIRM THE OPERATION

Confirm the operation again.

Is the inspection result normal?

YES >> Check intermittent incident. Refer to [GI-42, "Intermittent Incident"](#).

NO >> GO TO 1.

A
B
C
D
E
F
G
H
I
K
L
M
N
O
P

SE

SEATBACK HEATER ONLY DOES NOT OPERATE

< SYMPTOM DIAGNOSIS >

SEATBACK HEATER ONLY DOES NOT OPERATE

DRIVER SIDE

DRIVER SIDE : Diagnosis Procedure

INFOID:000000008158189

1.CHECK SEATBACK HEATER

Check seatback heater.

Refer to [SE-116, "DRIVER SIDE : Component Function Check"](#).

Is the inspection result normal?

YES >> GO TO 2.

NO >> Repair or replace the malfunctioning parts.

2.CONFIRM THE OPERATION

Confirm the operation again.

Is the inspection result normal?

YES >> Check intermittent incident. Refer to [GI-42, "Intermittent Incident"](#).

NO >> GO TO 1.

PASSENGER SIDE

PASSENGER SIDE : Diagnosis Procedure

INFOID:000000008158190

1.CHECK SEATBACK HEATER

Check seatback heater.

Refer to [SE-116, "PASSENGER SIDE : Component Function Check"](#).

Is the inspection result normal?

YES >> GO TO 2.

NO >> Repair or replace the malfunctioning parts.

2.CONFIRM THE OPERATION

Confirm the operation again.

Is the inspection result normal?

YES >> Check intermittent incident. Refer to [GI-42, "Intermittent Incident"](#).

NO >> GO TO 1.

CANNOT ADJUST HEATED SEAT TEMPERATURE

< SYMPTOM DIAGNOSIS >

CANNOT ADJUST HEATED SEAT TEMPERATURE

DRIVER SIDE

DRIVER SIDE : Diagnosis Procedure

INFOID:000000008158191

1.CHECK HEATED SEAT SWITCH

Check heated seat switch.

Refer to [SE-101, "DRIVER SIDE : Component Function Check"](#).

Is the inspection result normal?

YES >> GO TO 2.

NO >> Repair or replace the malfunctioning parts.

2.CHECK HEAT SENSOR

Check heat sensor.

Refer to [SE-107, "DRIVER SIDE : Description"](#).

Is the inspection result normal?

YES >> GO TO 3.

NO >> Repair or replace the malfunctioning parts.

3.CONFIRM THE OPERATION

Confirm the operation again.

Is the inspection result normal?

YES >> Check intermittent incident. Refer to [GI-42, "Intermittent Incident"](#).

NO >> Replace heated seat control unit. Refer to [SE-226, "Removal and Installation"](#).

PASSENGER SIDE

PASSENGER SIDE : Diagnosis Procedure

INFOID:000000008158192

1.CHECK HEATED SEAT SWITCH

Check heated seat switch.

Refer to [SE-102, "PASSENGER SIDE : Component Function Check"](#).

Is the inspection result normal?

YES >> GO TO 2.

NO >> Repair or replace the malfunctioning parts.

2.CHECK HEAT SENSOR

Check heat sensor.

Refer to [SE-109, "PASSENGER SIDE : Diagnosis Procedure"](#).

Is the inspection result normal?

YES >> GO TO 3.

NO >> Repair or replace the malfunctioning parts.

3.CONFIRM THE OPERATION

Confirm the operation again.

Is the inspection result normal?

YES >> Check intermittent incident. Refer to [GI-42, "Intermittent Incident"](#).

NO >> Replace heated seat control unit. Refer to [SE-226, "Removal and Installation"](#).

A
B
C
D
E
F
G
H
I
SE
K
L
M
N
O
P

HEATED SEAT SWITCH INDICATOR DOES NOT TURN ON

< SYMPTOM DIAGNOSIS >

HEATED SEAT SWITCH INDICATOR DOES NOT TURN ON DRIVER SIDE

DRIVER SIDE : Diagnosis Procedure

INFOID:000000008158193

1. CHECK HEATED SEAT SWITCH INDICATOR

Check heated seat switch indicator.

Refer to [SE-118, "DRIVER SIDE : Component Function Check"](#).

Is the inspection result normal?

YES >> GO TO 2.

NO >> Repair or replace the malfunctioning parts.

2. CONFIRM THE OPERATION

Confirm the operation again.

Is the inspection result normal?

YES >> Check intermittent incident. Refer to [GI-42, "Intermittent Incident"](#).

NO >> GO TO 1.

PASSENGER SIDE

PASSENGER SIDE : Diagnosis Procedure

INFOID:000000008158194

1. CHECK HEATED SEAT SWITCH INDICATOR

Check heated seat switch indicator.

Refer to [SE-118, "PASSENGER SIDE : Component Function Check"](#).

Is the inspection result normal?

YES >> GO TO 2.

NO >> Repair or replace the malfunctioning parts.

2. CONFIRM THE OPERATION

Confirm the operation again.

Is the inspection result normal?

YES >> Check intermittent incident. Refer to [GI-42, "Intermittent Incident"](#).

NO >> GO TO 1.

CLIMATE CONTROLLED SEAT DOES NOT OPERATE.

< SYMPTOM DIAGNOSIS >

CLIMATE CONTROLLED SEAT DOES NOT OPERATE.

DRIVER SIDE

DRIVER SIDE : Diagnosis Procedure

INFOID:000000008158195

Both sides

1.CHECK CLIMATE CONTROLLED SEAT CONTROL UNIT POWER SUPPLY CIRCUIT

Check climate controlled seat control unit power supply circuit.

Refer to [SE-44, "CLIMATE CONTROLLED SEAT CONTROL UNIT : Diagnosis Procedure"](#).

Is the inspection result normal?

YES >> GO TO 2.

NO >> Repair or replace the malfunctioning parts.

2.CHECK CLIMATE CONTROLLED SEAT SWITCH

Check climate controlled seat switch.

Refer to [SE-120, "Component Function Check"](#).

Is the inspection result normal?

YES >> GO TO 3.

NO >> Repair or replace the malfunctioning parts.

3.CONFIRM THE OPERATION

Confirm the operation again.

Is the inspection result normal?

YES >> Check intermittent incident. Refer to [GI-42, "Intermittent Incident"](#).

NO >> GO TO 1.

seatback

1.CHECK CLIMATE CONTROLLED SEATBACK BLOWER MOTOR

Check climate controlled seatback blower motor.

Refer to [SE-131, "Component Function Check"](#).

Is the inspection result normal?

YES >> GO TO 2.

NO >> Repair or replace the malfunctioning parts.

2.CONFIRM THE OPERATION

Confirm the operation again.

Is the inspection result normal?

YES >> Check intermittent incident. Refer to [GI-42, "Intermittent Incident"](#).

NO >> GO TO 1.

seat cushion

1.CHECK CLIMATE CONTROLLED SEAT CUSHION BLOWER MOTOR

Check climate controlled seat cushion blower motor.

Refer to [SE-134, "Component Function Check"](#).

Is the inspection result normal?

YES >> GO TO 2.

NO >> Repair or replace the malfunctioning parts.

2.CONFIRM THE OPERATION

Confirm the operation again.

Is the inspection result normal?

YES >> Check intermittent incident. Refer to [GI-42, "Intermittent Incident"](#).

NO >> GO TO 1.

A
B
C
D
E
F
G
H
I

SE

K
L
M
N

O
P

CLIMATE CONTROLLED SEAT DOES NOT OPERATE.

< SYMPTOM DIAGNOSIS >

PASSENGER SIDE

PASSENGER SIDE : Diagnosis Procedure

INFOID:000000008158196

Both sides

1.CHECK CLIMATE CONTROLLED SEAT CONTROL UNIT POWER SUPPLY AND GROUND CIRCUIT

Check climate controlled seat control unit power supply circuit.

Refer to [SE-44, "CLIMATE CONTROLLED SEAT CONTROL UNIT : Diagnosis Procedure"](#).

Is the inspection result normal?

YES >> GO TO 2.

NO >> Repair or replace the malfunctioning parts.

2.CHECK CLIMATE CONTROLLED SEAT SWITCH

Check climate controlled seat switch.

Refer to [SE-120, "Component Function Check"](#).

Is the inspection result normal?

YES >> GO TO 3.

NO >> Repair or replace the malfunctioning parts.

3.CONFIRM THE OPERATION

Confirm the operation again.

Is the inspection result normal?

YES >> Check intermittent incident. Refer to [GI-42, "Intermittent Incident"](#).

NO >> GO TO 1.

Seatback

1.CHECK CLIMATE CONTROLLED SEATBACK BLOWER MOTOR

Check climate controlled seatback blower motor.

Refer to [SE-131, "Component Function Check"](#).

Is the inspection result normal?

YES >> GO TO 2.

NO >> Repair or replace the malfunctioning parts.

2.CONFIRM THE OPERATION

Confirm the operation again.

Is the inspection result normal?

YES >> Check intermittent incident. Refer to [GI-42, "Intermittent Incident"](#).

NO >> GO TO 1.

Seat cushion

1.CHECK CLIMATE CONTROLLED SEAT CUSHION BLOWER MOTOR

Check climate controlled seat cushion blower motor.

Refer to [SE-134, "Component Function Check"](#).

Is the inspection result normal?

YES >> GO TO 2.

NO >> Repair or replace the malfunctioning parts.

2.CONFIRM THE OPERATION

Confirm the operation again.

Is the inspection result normal?

YES >> Check intermittent incident. Refer to [GI-42, "Intermittent Incident"](#).

NO >> GO TO 1.

TEMPERATURE ADJUSTMENT IS IMPOSSIBLE

< SYMPTOM DIAGNOSIS >

TEMPERATURE ADJUSTMENT IS IMPOSSIBLE

SEAT CUSHION BLOWER MOTOR

SEAT CUSHION BLOWER MOTOR : Description

INFOID:000000008158197

Blower fan motor noise is constant though performing temperature adjustment operation.

NOTE:

When turning climate controlled seat switch ON, blower fan motor may stay in the low speed operation for approximately 60 seconds. But this is not a malfunction.

SEAT CUSHION BLOWER MOTOR : Diagnosis Procedure

INFOID:000000008158198

1. CHECK CLIMATE CONTROLLED SEATBACK BLOWER FILTER

Check climate controlled seatback blower filter.

Refer to [SE-139. "SEATBACK BLOWER MOTOR : Diagnosis Procedure"](#).

Is the inspection result normal?

YES >> GO TO 2.

NO >> Repair or replace the malfunctioning parts.

2. CHECK CLIMATE CONTROLLED SEAT SWITCH

Check climate controlled seat switch.

Refer to [SE-120. "Component Function Check"](#).

Is the inspection result normal?

YES >> GO TO 3.

NO >> Repair or replace the malfunctioning parts.

3. CHECK CLIMATE CONTROLLED SEATBACK BLOWER MOTOR

Check climate controlled seatback blower motor.

Refer to [SE-131. "Component Function Check"](#).

Is the inspection result normal?

YES >> GO TO 4.

NO >> Repair or replace the malfunctioning parts.

4. CONFIRM THE OPERATION

Confirm the operation again.

Is the inspection result normal?

YES >> Check intermittent incident. Refer to [GI-42. "Intermittent Incident"](#).

NO >> GO TO 1.

SEAT CUSHION BLOWER MOTOR

SEAT CUSHION BLOWER MOTOR : Description

INFOID:000000008158199

Blower fan motor noise is constant though performing temperature adjustment operation.

NOTE:

When turning climate controlled seat switch ON, blower fan motor may stay in the low speed operation for approximately 60 seconds. But this is not a malfunction.

SEAT CUSHION BLOWER MOTOR : Diagnosis Procedure

INFOID:000000008158200

1. CHECK CLIMATE CONTROLLED SEAT CUSHION BLOWER FILTER

Check climate controlled seat cushion blower filter.

Refer to [SE-139. "SEAT CUSHION BLOWER MOTOR : Diagnosis Procedure"](#).

Is the inspection result normal?

YES >> GO TO 2.

NO >> Repair or replace the malfunctioning parts.

2. CHECK CLIMATE CONTROLLED SEAT SWITCH

TEMPERATURE ADJUSTMENT IS IMPOSSIBLE

< SYMPTOM DIAGNOSIS >

Check climate controlled seat switch.

Refer to [SE-120, "Component Function Check"](#).

Is the inspection result normal?

YES >> GO TO 3.

NO >> Repair or replace the malfunctioning parts.

3.CHECK CLIMATE CONTROLLED SEAT CUSHION BLOWER MOTOR

Check climate controlled seat cushion blower motor.

Refer to [SE-134, "Component Function Check"](#).

Is the inspection result normal?

YES >> GO TO 4.

NO >> Repair or replace the malfunctioning parts.

4.CONFIRM THE OPERATION

Confirm the operation again.

Is the inspection result normal?

YES >> Check intermittent incident. Refer to [GI-42, "Intermittent Incident"](#).

NO >> GO TO 1.

CLIMATE CONTROLLED SEAT DOES NOT OPERATES WHEN SWITCH IS DONE IN HEAT OR COOL.

< SYMPTOM DIAGNOSIS >

CLIMATE CONTROLLED SEAT DOES NOT OPERATES WHEN SWITCH IS DONE IN HEAT OR COOL.

Diagnosis Procedure

INFOID:000000008158201

1.CHECK CLIMATE CONTROLLED SEAT SWITCH

Check climate controlled seat switch.

Refer to [SE-120, "Component Function Check"](#).

Is the inspection result normal?

YES >> GO TO 2.

NO >> Repair or replace the malfunctioning parts.

2.CONFIRM THE OPERATION

Confirm the operation again.

Is the inspection result normal?

YES >> Check intermittent incident. Refer to [GI-42, "Intermittent Incident"](#).

NO >> GO TO 1.

A
B
C
D
E
F
G
H
I
K
L
M
N
O
P

SE

CLIMATE CONTROLLED SEAT ACTIVATES ONCE BUT STOPS IMMEDIATELY

< SYMPTOM DIAGNOSIS >

CLIMATE CONTROLLED SEAT ACTIVATES ONCE BUT STOPS IMMEDIATELY

SEATBACK BLOWER MOTOR

SEATBACK BLOWER MOTOR : Description

INFOID:000000008158202

When turning climate controlled seat switch ON (COOL or HEAT), climate controlled seat activates once but stops immediately.(Repeats the same operation when turning ignition switch OFF and turning ignition switch ON again.)

SEATBACK BLOWER MOTOR : Diagnosis Procedure

INFOID:000000008158203

1.CHECK CLIMATE CONTROLLED SEATBACK BLOWER FILTER

Check climate controlled seatback blower filter.

Refer to [SE-139, "SEATBACK BLOWER MOTOR : Diagnosis Procedure"](#).

Is the inspection result normal?

YES >> GO TO 2.

NO >> Repair or replace the malfunctioning parts.

2.CHECK SEATBACK THERMAL ELECTRIC DEVICE SENSOR

Check seatback thermal electric device sensor.

Refer to [SE-125, "Diagnosis Procedure"](#).

Is the inspection result normal?

YES >> GO TO 3.

NO >> Repair or replace the malfunctioning parts.

3.CHECK SEATBACK THERMAL ELECTRIC DEVICE

Check seatback thermal electric device.

Refer to [SE-123, "Component Function Check"](#).

Is the inspection result normal?

YES >> GO TO 4.

NO >> Repair or replace the malfunctioning parts.

4.CHECK CLIMATE CONTROLLED SEATBACK BLOWER MOTOR

Check climate controlled seatback blower motor.

Refer to [SE-131, "Component Function Check"](#).

Is the inspection result normal?

YES >> GO TO 5.

NO >> Repair or replace the malfunctioning parts.

5.CONFIRM THE OPERATION

Confirm the operation again.

Is the inspection result normal?

YES >> Check intermittent incident. Refer to [GI-42, "Intermittent Incident"](#).

NO >> GO TO 1.

SEAT CUSHION BLOWER MOTOR

SEAT CUSHION BLOWER MOTOR : Description

INFOID:000000008158204

When turning climate controlled seat switch ON (COOL or HEAT), climate controlled seat activates once but stops immediately.(Repeats the same operation when turning ignition switch OFF and turning ignition switch ON again.)

SEAT CUSHION BLOWER MOTOR : Diagnosis Procedure

INFOID:000000008158205

1.CHECK CLIMATE CONTROLLED SEAT CUSHION BLOWER FILTER

CLIMATE CONTROLLED SEAT ACTIVATES ONCE BUT STOPS IMMEDIATELY

< SYMPTOM DIAGNOSIS >

Check climate controlled seat cushion blower filter.

Refer to [SE-139, "SEAT CUSHION BLOWER MOTOR : Diagnosis Procedure"](#).

Is the inspection result normal?

YES >> GO TO 2.

NO >> Repair or replace the malfunctioning parts.

2.CHECK SEAT CUSHION THERMAL ELECTRIC DEVICE SENSOR

Check seat cushion thermal electric device sensor.

Refer to [SE-129, "Diagnosis Procedure"](#).

Is the inspection result normal?

YES >> GO TO 3.

NO >> Repair or replace the malfunctioning parts.

3.CHECK SEAT CUSHION THERMAL ELECTRIC DEVICE

Check seat cushion thermal electric device.

Refer to [SE-127, "Component Function Check"](#).

Is the inspection result normal?

YES >> GO TO 4.

NO >> Repair or replace the malfunctioning parts.

4.CHECK CLIMATE CONTROLLED SEAT CUSHION BLOWER MOTOR

Check climate controlled seat cushion blower motor.

Refer to [SE-134, "Component Function Check"](#).

Is the inspection result normal?

YES >> GO TO 5.

NO >> Repair or replace the malfunctioning parts.

5.CONFIRM THE OPERATION

Confirm the operation again.

Is the inspection result normal?

YES >> Check intermittent incident. Refer to [GI-42, "Intermittent Incident"](#).

NO >> GO TO 1.

A

B

C

D

E

F

G

H

I

SE

K

L

M

N

O

P

SEAT SWITCH INDICATOR IS NOT ILLUMINATED IN HEAT OR COOL POSITION

< SYMPTOM DIAGNOSIS >

SEAT SWITCH INDICATOR IS NOT ILLUMINATED IN HEAT OR COOL POSITION

Diagnosis Procedure

INFOID:000000008158206

1. CHECK CLIMATE CONTROLLED SEAT SWITCH INDICATOR

Check climate controlled seat indicator.

Refer to [SE-137, "Component Function Check"](#).

Is the inspection result normal?

YES >> GO TO 2.

NO >> Repair or replace the malfunctioning parts.

2. CONFIRM THE OPERATION

Confirm the operation again.

Is the inspection result normal?

YES >> Check intermittent incident. Refer to [GI-42, "Intermittent Incident"](#).

NO >> GO TO 1.

SQUEAK AND RATTLE TROUBLE DIAGNOSES

< SYMPTOM DIAGNOSIS >

SQUEAK AND RATTLE TROUBLE DIAGNOSES

Work Flow

INFOID:000000008158207

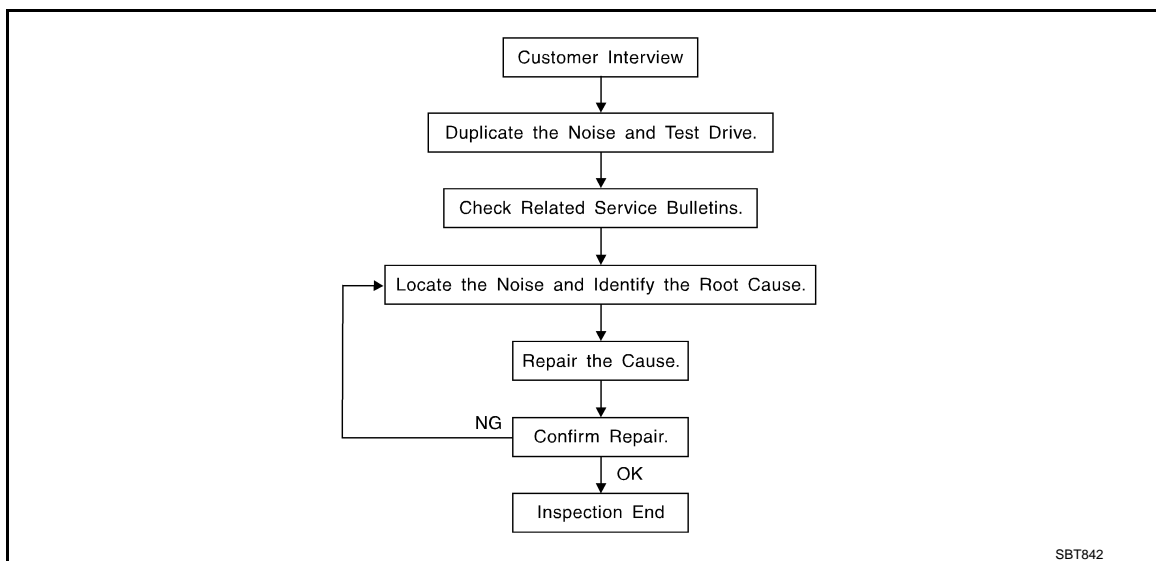

CUSTOMER INTERVIEW

Interview the customer if possible, to determine the conditions that exist when the noise occurs. Use the Diagnostic Worksheet during the interview to document the facts and conditions when the noise occurs and any of customer's comments; refer to [SE-193, "Diagnostic Worksheet"](#). This information is necessary to duplicate the conditions that exist when the noise occurs.

- The customer may not be able to provide a detailed description or the location of the noise. Attempt to obtain all the facts and conditions that exist when the noise occurs (or does not occur).
- If there is more than one noise in the vehicle, perform a diagnosis and repair the noise that the customer is concerned about. This can be accomplished by performing a cruise test on the vehicle with the customer.
- After identifying the type of noise, isolate the noise in terms of its characteristics. The noise characteristics are provided so the customer, service adviser and technician are all speaking the same language when defining the noise.
- Squeak – (Like tennis shoes on a clean floor)
Squeak characteristics include the light contact/fast movement/brought on by road conditions/hard surfaces = higher pitch noise/softer surfaces = lower pitch noises/edge to surface = chirping
- Creak – (Like walking on an old wooden floor)
Creak characteristics include firm contact/slow movement/twisting with a rotational movement/pitch dependent on materials/often brought on by activity.
- Rattle – (Like shaking a baby rattle)
Rattle characteristics include the fast repeated contact/vibration or similar movement/loose parts/missing clip or fastener/incorrect clearance.
- Knock – (Like a knock on a door)
Knock characteristics include hollow sounding/sometimes repeating/often brought on by driver action.
- Tick – (Like a clock second hand)
Tick characteristics include gentle contacting of light materials/loose components/can be caused by driver action or road conditions.
- Thump – (Heavy, muffled knock noise)
Thump characteristics include softer knock/dead sound often brought on by activity.
- Buzz – (Like a bumblebee)
Buzz characteristics include high frequency rattle/firm contact.
- Often the degree of acceptable noise level will vary depending up on the person. A noise that a technician may judge as acceptable may be very irritating to the customer.
- Weather conditions, especially humidity and temperature, may have a great effect on noise level.

DUPLICATE THE NOISE AND TEST DRIVE

If possible, drive the vehicle with the customer until the noise is duplicated. Note any additional information on the Diagnostic Worksheet regarding the conditions or location of the noise. This information can be used to duplicate the same conditions when the repair is reconfirmed.

SQUEAK AND RATTLE TROUBLE DIAGNOSES

< SYMPTOM DIAGNOSIS >

If the noise can be duplicated easily during the test drive, to help identify the source of the noise, try to duplicate the noise with the vehicle stopped by doing one or all of the following:

- 1) Close a door.
 - 2) Tap or push/pull around the area where the noise appears to be coming from.
 - 3) Rev the engine.
 - 4) Use a floor jack to recreate vehicle "twist".
 - 5) At idle, apply engine load (electrical load, half-clutch on M/T models, drive position on A/T models).
 - 6) Raise the vehicle on a hoist and hit a tire with a rubber hammer.
- Drive the vehicle and attempt to duplicate the conditions the customer states exist when the noise occurs.
 - If it is difficult to duplicate the noise, drive the vehicle slowly on an undulating or rough road to stress the vehicle body.

CHECK RELATED SERVICE BULLETINS

After verifying the customer concern or symptom, check ASIST for Technical Service Bulletins (TSBs) related to that concern or symptom.

If a TSB relates to the symptom, follow the procedure to repair the noise.

LOCATE THE NOISE AND IDENTIFY THE ROOT CAUSE

1. Narrow down the noise to a general area. To help pinpoint the source of the noise, use a listening tool (Chassis ear: J-39570, Engine ear and mechanics stethoscope).
2. Narrow down the noise to a more specific area and identify the cause of the noise by:
 - Removing the components in the area that is are suspected to be the cause of the noise.
Do not use too much force when removing clips and fasteners, otherwise clips and fastener can be broken or lost during the repair, resulting in the creation of new noise.
 - Tapping or pushing/pulling the component that is are suspected to be the cause of the noise.
Do not tap or push/pull the component with excessive force, otherwise the noise will be eliminated only temporarily.
 - Feeling for a vibration by hand by touching the component(s) that is are suspected to be the cause of the noise.
 - Placing a piece of paper between components that are suspected to be the cause of the noise.
 - Looking for loose components and contact marks.
Refer to [SE-191, "Inspection Procedure"](#).

REPAIR THE CAUSE

- If the cause is a loose component, tighten the component securely.
- If the cause is insufficient clearance between components:
 - Separate components by repositioning or loosening and retightening the component, if possible.
 - Insulate components with a suitable insulator such as urethane pads, foam blocks, felt cloth tape or urethane tape. A Nissan Squeak and Rattle Kit (J-43980) is available through the authorized Nissan Parts Department.

CAUTION:

Never use excessive force as many components are constructed of plastic and may be damaged.

NOTE:

Always check with the Parts Department for the latest parts information.

The following materials are contained in the Nissan Squeak and Rattle Kit (J-43980). Each item can be ordered separately as needed.

URETHANE PADS [1.5 mm (0.059 in) thick]

Insulates connectors, harness, etc.

76268-9E005: 100 × 135 mm (3.94 × 5.31 in)/76884-71L01: 60 × 85 mm (2.36 × 3.35 in)/76884-71L02: 15 × 25 mm (0.59 × 0.98 in)

INSULATOR (Foam blocks)

Insulates components from contact. Can be used to fill space behind a panel.

73982-9E000: 45 mm (1.77 in) thick, 50 × 50 mm (1.97 × 1.97 in)/73982-

50Y00: 10 mm (0.39 in) thick, 50 × 50 mm (1.97 × 1.97 in)

INSULATOR (Light foam block)

80845-71L00: 30 mm (1.18 in) thick, 30 × 50 mm (1.18 × 1.97in)

FELT CLOTHTAPE

Used to insulate where movement does not occur. Ideal for instrument panel applications.

68370-4B000: 15 × 25 mm (0.59 × 0.98 in) pad/68239-13E00: 5 mm (0.20 in) wide tape roll

The following materials, not found in the kit, can also be used to repair squeaks and rattles.

UHMW (TEFLON) TAPE

SQUEAK AND RATTLE TROUBLE DIAGNOSES

< SYMPTOM DIAGNOSIS >

Insulates where slight movement is present. Ideal for instrument panel applications.

SILICONE GREASE

Used in place of UHMW tape that is be visible or does not fit. Will only last a few months.

SILICONE SPRAY

Used when grease cannot be applied.

DUCT TAPE

Used to eliminate movement.

CONFIRM THE REPAIR

Confirm that the cause of a noise is repaired by test driving the vehicle. Operate the vehicle under the same conditions as when the noise originally occurred. Refer to the notes on the Diagnostic Worksheet.

Inspection Procedure

INFOID:000000008158208

Refer to Table of Contents for specific component removal and installation information.

INSTRUMENT PANEL

Most incidents are caused by contact and movement between:

1. The cluster lid A and instrument panel
2. Acrylic lens and combination meter housing
3. Instrument panel to front pillar garnish
4. Instrument panel to windshield
5. Instrument panel mounting pins
6. Wiring harnesses behind the combination meter
7. A/C defroster duct and duct joint

These incidents can usually be located by tapping or moving the components to duplicate the noise or by pressing on the components while driving to stop the noise. Most of these incidents can be repaired by applying felt cloth tape or silicon spray (in hard to reach areas). Urethane pads can be used to insulate wiring harness.

CAUTION:

Never use silicone spray to isolate a squeak or rattle. If the area is saturated with silicone, the recheck of repair becomes impossible.

CENTER CONSOLE

Components to pay attention to include:

1. Shifter assembly cover to finisher
2. A/C control unit and cluster lid C
3. Wiring harnesses behind audio and A/C control unit

The instrument panel repair and isolation procedures also apply to the center console.

DOORS

Pay attention to the following:

1. Finisher and inner panel making a slapping noise
2. Inside handle escutcheon to door finisher
3. Wiring harnesses tapping
4. Door striker out of alignment causing a popping noise on starts and stops

Tapping or moving the components or pressing on them while driving to duplicate the conditions can isolate many of these incidents. The areas can usually be insulated with felt cloth tape or insulator foam blocks from the Nissan Squeak and Rattle Kit (J-43980) to repair the noise.

TRUNK

Trunk noises are often caused by a loose jack or loose items put into the trunk by the customer.

In addition look for the following:

1. Trunk lid dumpers out of adjustment
2. Trunk lid striker out of adjustment
3. The trunk lid torsion bars knocking together
4. A loose license plate or bracket

SQUEAK AND RATTLE TROUBLE DIAGNOSES

< SYMPTOM DIAGNOSIS >

Most of these incidents can be repaired by adjusting, securing or insulating the item(s) or component(s) causing the noise.

SUNROOF/HEADLINING

Noises in the sunroof/headlining area can often be traced to one of the following:

1. Sunroof lid, rail, linkage or seals making a rattle or light knocking noise
2. Sunvisor shaft shaking in the holder
3. Front or rear windshield touching headlining and squeaking

Again, pressing on the components to stop the noise while duplicating the conditions can isolate most of these incidents. Repairs usually consist of insulating with felt cloth tape.

SEATS

When isolating seat noise it's important to note the position the seats in and the load placed on the seat when the noise occurs. These conditions should be duplicated when verifying and isolating the cause of the noise.

Cause of seat noise include:

1. Headrest rods and holder
2. A squeak between the seat pad cushion and frame
3. The rear seatback lock and bracket

These noises can be isolated by moving or pressing on the suspected components while duplicating the conditions under which the noise occurs. Most of these incidents can be repaired by repositioning the component or applying urethane tape to the contact area.

UNDERHOOD

Some interior noise may be caused by components under the hood or on the engine wall. The noise is then transmitted into the passenger compartment.

Causes of transmitted underhood noise include:

1. Any component mounted to the engine wall
2. Components that pass through the engine wall
3. Engine wall mounts and connectors
4. Loose radiator mounting pins
5. Hood bumpers out of adjustment
6. Hood striker out of adjustment

These noises can be difficult to isolate since they cannot be reached from the interior of the vehicle. The best method is to secure, move or insulate one component at a time and test drive the vehicle. Also, engine RPM or load can be changed to isolate the noise. Repairs can usually be made by moving, adjusting, securing, or insulating the component causing the noise.

SQUEAK AND RATTLE TROUBLE DIAGNOSES

< SYMPTOM DIAGNOSIS >

Diagnostic Worksheet

INFOID:000000008158209



SQUEAK & RATTLE DIAGNOSTIC WORKSHEET

Dear Infiniti Customer:

We are concerned about your satisfaction with your Infiniti vehicle. Repairing a squeak or rattle sometimes can be very difficult. To help us fix your Infiniti right the first time, please take a moment to note the area of the vehicle where the squeak or rattle occurs and under what conditions. You may be asked to take a test drive with a service consultant or technician to ensure we confirm the noise you are hearing.

I. WHERE DOES THE NOISE COME FROM? (circle the area of the vehicle)

The illustrations are for reference only, and may not reflect the actual configuration of your vehicle.

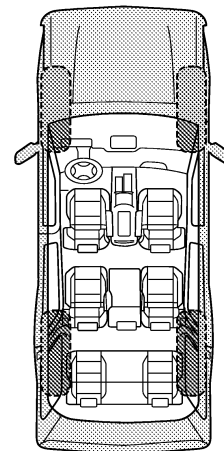
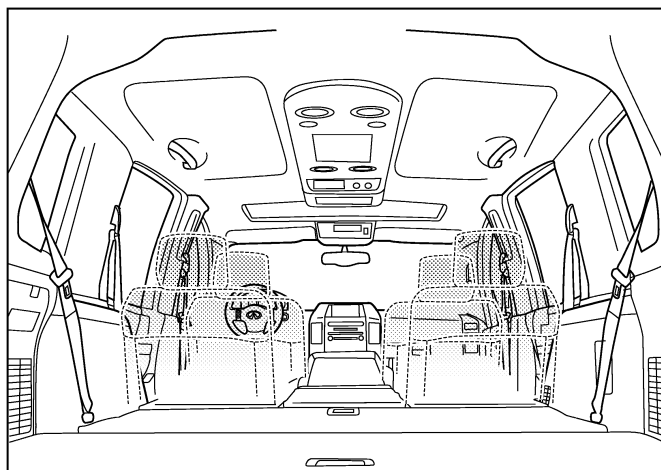
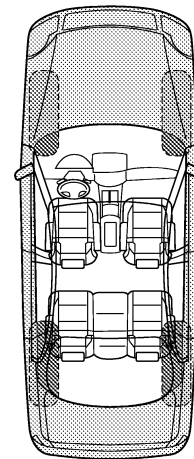
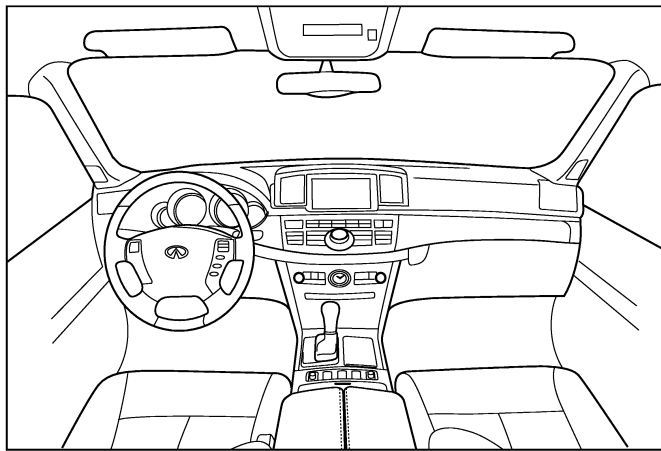

Continue to page 2 of the worksheet and briefly describe the location of the noise or rattle. In addition, please indicate the conditions which are present when the noise occurs.

PIIB8741E

A
B
C
D
E
F
G
H
I
SE
K
L
M
N
O
P

SQUEAK AND RATTLE TROUBLE DIAGNOSES

< SYMPTOM DIAGNOSIS >

SQUEAK & RATTLE DIAGNOSTIC WORKSHEET - page 2

Briefly describe the location where the noise occurs:

II. WHEN DOES IT OCCUR? (please check the boxes that apply)

- | | |
|---|--|
| <input type="checkbox"/> anytime | <input type="checkbox"/> after sitting out in the rain |
| <input type="checkbox"/> 1st time in the morning | <input type="checkbox"/> when it is raining or wet |
| <input type="checkbox"/> only when it is cold outside | <input type="checkbox"/> dry or dusty conditions |
| <input type="checkbox"/> only when it is hot outside | <input type="checkbox"/> other: |

III. WHEN DRIVING:

- through driveways
- over rough roads
- over speed bumps
- only about ____ mph
- on acceleration
- coming to a stop
- on turns: left, right or either (circle)
- with passengers or cargo
- other: _____
- after driving ____ miles or ____ minutes

IV. WHAT TYPE OF NOISE

- squeak (like tennis shoes on a clean floor)
- creak (like walking on an old wooden floor)
- rattle (like shaking a baby rattle)
- knock (like a knock at the door)
- tick (like a clock second hand)
- thump (heavy, muffled knock noise)
- buzz (like a bumble bee)

TO BE COMPLETED BY DEALERSHIP PERSONNEL

Test Drive Notes:

	YES	NO	Initials of person performing
Vehicle test driven with customer	<input type="checkbox"/>	<input type="checkbox"/>	_____
- Noise verified on test drive	<input type="checkbox"/>	<input type="checkbox"/>	_____
- Noise source located and repaired	<input type="checkbox"/>	<input type="checkbox"/>	_____
- Follow up test drive performed to confirm repair	<input type="checkbox"/>	<input type="checkbox"/>	_____

VIN: _____ Customer Name: _____
W.O.# _____ Date: _____

This form must be attached to Work Order

PIIB8742E

PRECAUTIONS

< PRECAUTION >

PRECAUTION

PRECAUTIONS

Precaution for Supplemental Restraint System (SRS) "AIR BAG" and "SEAT BELT PRE-TENSIONER"

INFOID:000000008158210

The Supplemental Restraint System such as "AIR BAG" and "SEAT BELT PRE-TENSIONER", used along with a front seat belt, helps to reduce the risk or severity of injury to the driver and front passenger for certain types of collision. This system includes seat belt switch inputs and dual stage front air bag modules. The SRS system uses the seat belt switches to determine the front air bag deployment, and may only deploy one front air bag, depending on the severity of a collision and whether the front occupants are belted or unbelted. Information necessary to service the system safely is included in the "SRS AIR BAG" and "SEAT BELT" of this Service Manual.

WARNING:

Always observe the following items for preventing accidental activation.

- To avoid rendering the SRS inoperative, which could increase the risk of personal injury or death in the event of a collision that would result in air bag inflation, all maintenance must be performed by an authorized NISSAN/INFINITI dealer.
- Improper maintenance, including incorrect removal and installation of the SRS, can lead to personal injury caused by unintentional activation of the system. For removal of Spiral Cable and Air Bag Module, see "SRS AIR BAG".
- Never use electrical test equipment on any circuit related to the SRS unless instructed to in this Service Manual. SRS wiring harnesses can be identified by yellow and/or orange harnesses or harness connectors.

PRECAUTIONS WHEN USING POWER TOOLS (AIR OR ELECTRIC) AND HAMMERS

WARNING:

Always observe the following items for preventing accidental activation.

- When working near the Air Bag Diagnosis Sensor Unit or other Air Bag System sensors with the ignition ON or engine running, never use air or electric power tools or strike near the sensor(s) with a hammer. Heavy vibration could activate the sensor(s) and deploy the air bag(s), possibly causing serious injury.
- When using air or electric power tools or hammers, always switch the ignition OFF, disconnect the battery, and wait at least 3 minutes before performing any service.

Service Procedure Precautions for Models with a Pop-up Roll Bar

INFOID:000000008158211

WARNING:

Always observe the following items for preventing accidental activation.

- Risk of passenger injury or death may increase if the pop-up roll bar does not deploy during a roll over collision. In order to reduce the chance of an incident where the pop-up roll bar is inoperative, all maintenance must be performed by a NISSAN or INFINITI dealer.
- Before removing and installing the pop-up roll bar component parts and harness, always turn the ignition switch OFF, disconnect the battery negative terminal, and wait for 3 minutes or more. (The purpose of this operation is to discharge electricity that is accumulated in the auxiliary power supply circuit in the air bag diagnosis sensor unit.)
- When repairing, removing, and installing a pop-up roll bar, always refer to SRS AIR BAG and SRS AIR BAG CONTROL warnings in the Service Manual.

Precaution for Battery Service

INFOID:000000008158212

Before disconnecting the battery, lower both the driver and passenger windows. This will prevent any interference between the window edge and the vehicle when the door is opened/closed. During normal operation, the window slightly raises and lowers automatically to prevent any window to vehicle interference. The automatic window function will not work with the battery disconnected.

Service Notice

INFOID:000000008158213

- When removing or installing various parts, place a cloth or padding onto the vehicle body to prevent scratches.

PRECAUTIONS

< PRECAUTION >

- Handle trim, molding, instruments, grille, etc. carefully during removing or installing. Be careful not to oil or damage them.
- Apply sealing compound where necessary when installing parts.
- When applying sealing compound, be careful that the sealing compound does not protrude from parts.
- When replacing any metal parts (for example body outer panel, members, etc.), be sure to take rust prevention measures.

Precaution for Work

INFOID:000000008158214

- When removing or disassembling each component, be careful not to damage or deform it. If a component may be subject to interference, be sure to protect it with a shop cloth.
- When removing (disengaging) components with a screwdriver or similar tool, be sure to wrap the component with a shop cloth or vinyl tape to protect it.
- Protect the removed parts with a shop cloth and keep them.
- Replace a deformed or damaged clip.
- If a part is specified as a non-reusable part, always replace it with new one.
- Be sure to tighten bolts and nuts securely to the specified torque.
- After re-installation is completed, be sure to check that each part works normally.
- Follow the steps below to clean components.
 - Water soluble foul: Dip a soft cloth into lukewarm water, and wring the water out of the cloth to wipe the fouled area.
Then rub with a soft and dry cloth.
 - Oily foul: Dip a soft cloth into lukewarm water with mild detergent (concentration: within 2 to 3%), and wipe the fouled area.
Then dip a cloth into fresh water, and wring the water out of the cloth to wipe the detergent off. Then rub with a soft and dry cloth.
- Do not use organic solvent such as thinner, benzene, alcohol, and gasoline.
- For genuine leather seats, use a genuine leather seat cleaner.

PREPARATION

< PREPARATION >

PREPARATION

PREPARATION

Special Service Tool

INFOID:000000008158215

The actual shapes of Kent-Moore tools may differ from those of special service tools illustrated here.

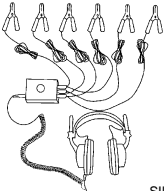
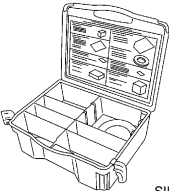
Tool number (Kent-Moore No.) Tool name	Description
<p>(J39570) Chassis ear</p>  <p>SIIA0993E</p>	<p>Locates the noise</p>
<p>(J43980) NISSAN Squeak and Rattle Kit</p>  <p>SIIA0994E</p>	<p>Repairs the cause of noise</p>

Commercial Service Tool

INFOID:000000008158216

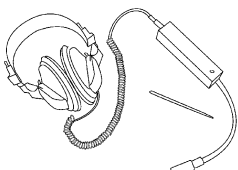
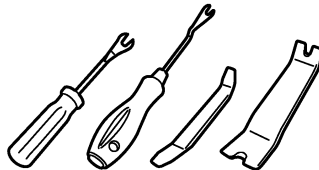
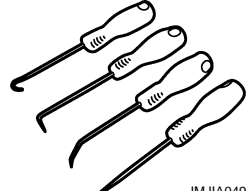
Tool name	Description
<p>Engine ear</p>  <p>SIIA0995E</p>	<p>Locates the noise</p>
<p>Remover tool</p>  <p>JMKIA3050ZZ</p>	<p>Removes the clips, pawls and metal clips</p>
<p>Hook and pick tool</p>  <p>JMJA0490ZZ</p>	<p>Removes the snap pins</p>

CLIP LIST

< PREPARATION >

CLIP LIST

Clip List

INFOID:000000008158217

Shapes	Removal & Installation	Shapes	Removal & Installation
	<p>Removal: Remove by bending up with flat-bladed screwdrivers or clip remover.</p>		<p>Removal:</p>
	<p>Removal: Remove with a clip remover.</p>		<p>Removal:</p>
	<p>Removal: Push center pin to catching position. (Do not remove center pin by hitting it.)</p> <p>Installation:</p>		<p>Removal: Holder portion of clip must be spread out to remove rod.</p>
	<p>Removal: Remove by bending up with flat-bladed screwdrivers or clip remover.</p>		<p>Removal:</p> <ol style="list-style-type: none"> Screw out with a Phillips screwdriver. Remove female portion with flat-bladed screwdriver.
	<p>Removal:</p>		<p>Removal:</p> <p>Rotate 45° to remove.</p> <p>Installation:</p>
	<p>Removal:</p>		<p>Removal:</p>

JMJIA3734GB

FRONT SEAT

< REMOVAL AND INSTALLATION >

REMOVAL AND INSTALLATION

FRONT SEAT

Exploded View

INFOID:000000008158218

DRIVER'S SEAT

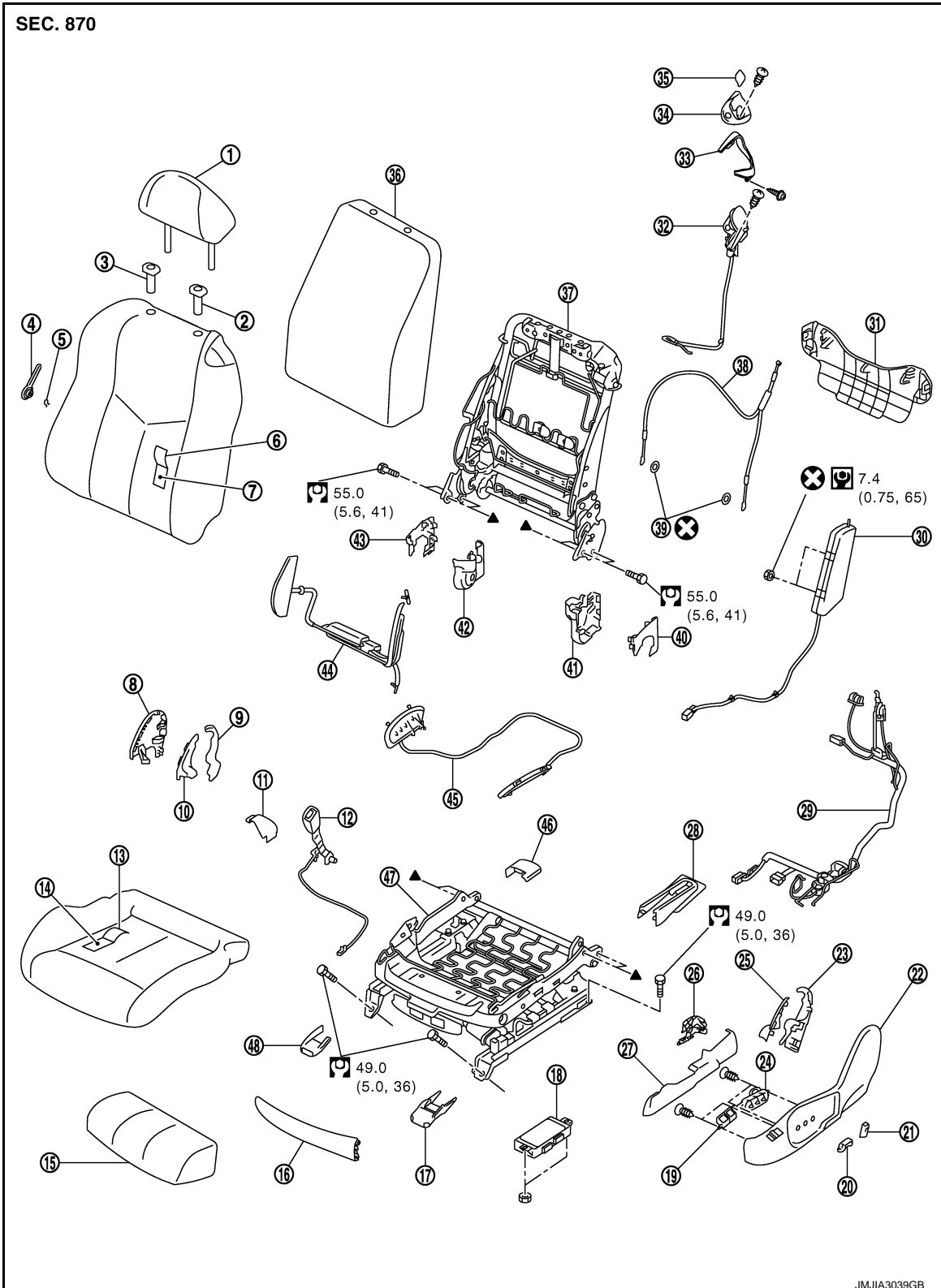

A
B
C
D
E
F
G
H
I
SE
K
L
M
N
O
P

FRONT SEAT

< REMOVAL AND INSTALLATION >

- | | | |
|--|---|--|
| 1. Headrest | 2. Headrest holder (locked) | 3. Headrest holder (free) |
| 4. Lumber support lever knob | 5. Snap ring | 6. Seatback trim |
| 7. Seatback pad | 8. Seat cushion inner finisher | 9. Seat cushion inner finisher inside (rear) |
| 10. Seat cushion inner finisher inside (front) | 11. Seat slide inner finisher | 12. Seat belt buckle |
| 13. Seat cushion trim | 14. Seat cushion pad | 15. Seat cushion pad (front) |
| 16. Seat cushion front finisher | 17. Front outer slide cover | 18. Seat control unit |
| 19. Side support switch | 20. Seat slide and lifter switch knob | 21. Seat reclining switch knob |
| 22. Seat cushion outer finisher | 23. Seat cushion outer finisher inside (rear) | 24. Seat control switch |
| 25. Seat cushion outer finisher inside (front) | 26. Seat slide outer finisher (inside) | 27. Seat slide outer finisher (outside) |
| 28. Rear outer slide cover | 29. Seat harness | 30. Side air bag module |
| 31. Seatback lower panel | 32. Walk-in lever | 33. Walk-in lever lower escutcheon |
| 34. Walk-in lever upper escutcheon | 35. Walk-in lever cap | 36. Seatback silencer |
| 37. Seatback frame | 38. Reclining device wire | 39. Push nut |
| 40. Reclining device outer cover (outside) | 41. Reclining device outer cover (inside) | 42. Reclining device inner cover (inside) |
| 43. Reclining device inner cover (outside) | 44. Seatback side support bag and unit | 45. Seat cushion side support bag |
| 46. Rear inner slide cover | 47. Seat cushion frame | 48. Front inner slide cover |

Refer to [GI-4, "Components"](#) for symbols in the figure.

DRIVER'S SEAT WITH HEADREST SPEAKER

FRONT SEAT

< REMOVAL AND INSTALLATION >

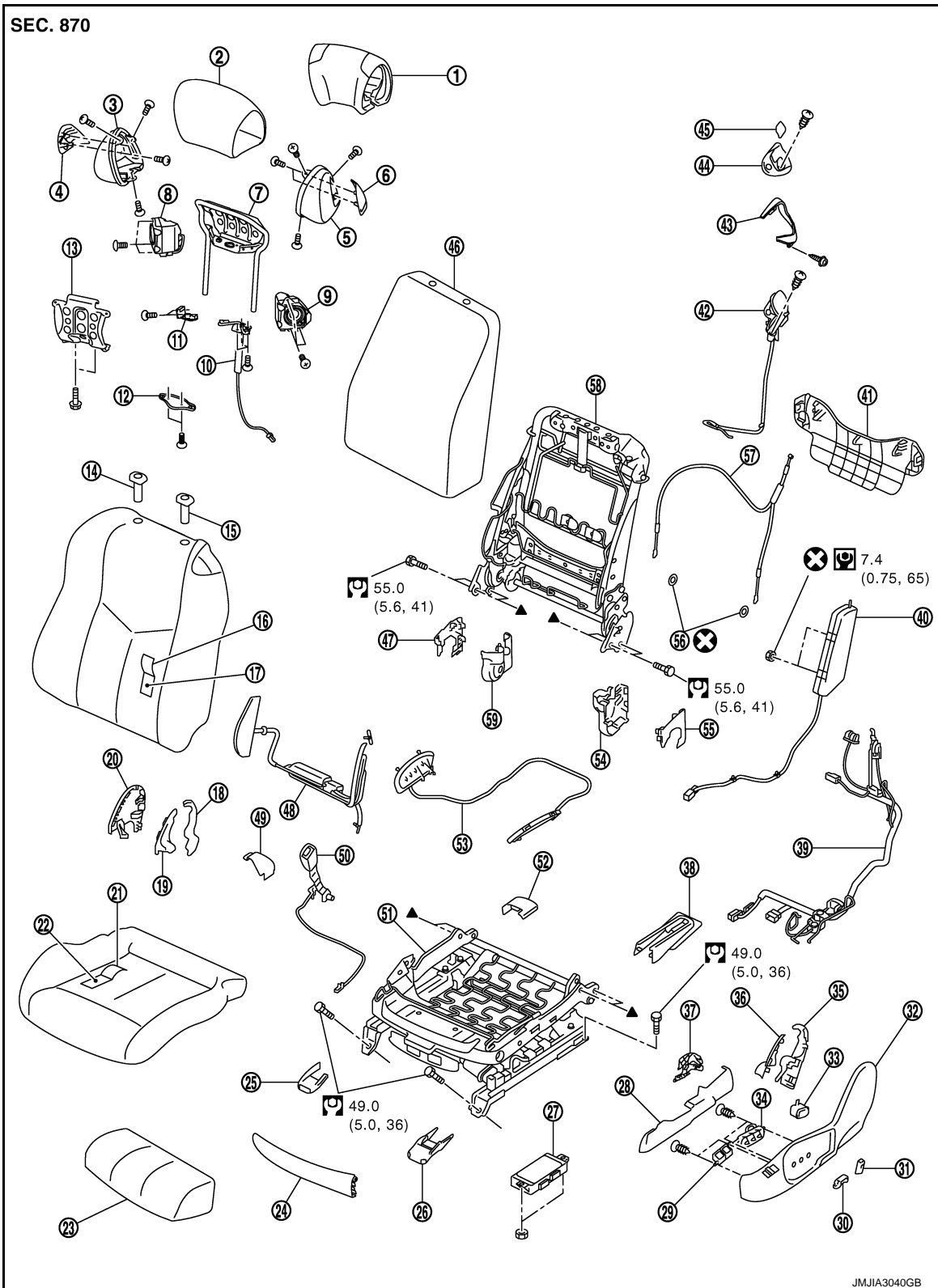

- | | | |
|------------------------------|----------------------------------|----------------------------------|
| 1. Headrest pad | 2. Headrest trim cover | 3. Headrest inner grille |
| 4. Headrest inner escutcheon | 5. Headrest outer grille | 6. Headrest outer escutcheon |
| 7. Headrest frame | 8. Driver headrest inner speaker | 9. Driver headrest outer speaker |
| 10. Headrest harness | 11. Microphone (for AudioPilot®) | 12. Headrest cover |
| 13. Headrest frame front | 14. Headrest holder (free) | 15. Headrest holder (locked) |

A
B
C
D
E
F
G
H
I
SE
K
L
M
N
O
P

FRONT SEAT

< REMOVAL AND INSTALLATION >

- | | | |
|--|---|--|
| 16. Seatback trim | 17. Seatback pad | 18. Seat cushion inner finisher inside (rear) |
| 19. Seat cushion inner finisher inside (front) | 20. Seat cushion inner finisher | 21. Seat cushion trim |
| 22. Seat cushion pad | 23. Seat cushion pad (front) | 24. Seat cushion front finisher |
| 25. Front inner slide cover | 26. Front outer slide cover | 27. Seat control unit |
| 28. Seat slide outer finisher (outside) | 29. Side support switch | 30. Seat slide and lifter switch knob |
| 31. Seat reclining switch knob | 32. Seat cushion outer finisher | 33. Lumber support switch |
| 34. Seat control switch | 35. Seat cushion outer finisher inside (rear) | 36. Seat cushion outer finisher inside (front) |
| 37. Seat slide outer finisher (inside) | 38. Rear outer slide cover | 39. Seat harness |
| 40. Side air bag module | 41. Seatback lower panel | 42. Walk-in lever |
| 43. Walk-in lever lower escutcheon | 44. Walk-in lever upper escutcheon | 45. Walk-in lever cap |
| 46. Seatback silencer | 47. Reclining device inner cover (outside) | 48. Seatback side support bag and unit |
| 49. Seat slide inner finisher | 50. Seat belt buckle | 51. Seat cushion frame |
| 52. Rear inner slide cover | 53. Seat cushion side support bag | 54. Reclining device outer cover (inside) |
| 55. Reclining device outer cover (outside) | 56. Push nut | 57. Reclining device wire |
| 58. Seatback frame | 59. Reclining device inner cover (inside) | |

Refer to [GI-4, "Components"](#) for symbols in the figure.

DRIVER'S SEAT WITH HEADREST SPEAKER AND AIR CONDITIONER

FRONT SEAT

< REMOVAL AND INSTALLATION >

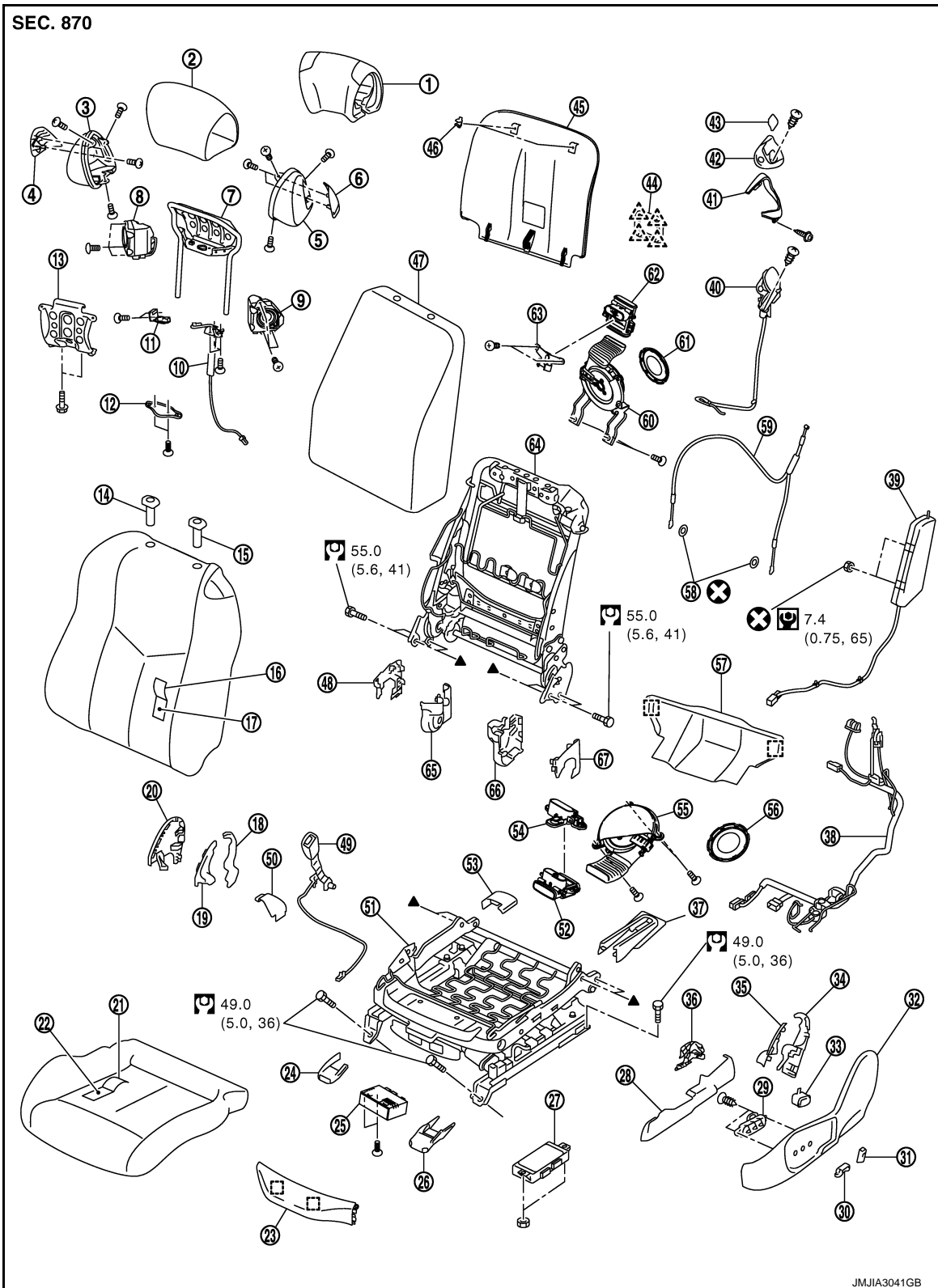

- | | | |
|------------------------------|----------------------------------|----------------------------------|
| 1. Headrest pad | 2. Headrest trim cover | 3. Headrest inner grille |
| 4. Headrest inner escutcheon | 5. Headrest outer grille | 6. Headrest outer escutcheon |
| 7. Headrest frame | 8. Driver headrest inner speaker | 9. Driver headrest outer speaker |
| 10. Headrest harness | 11. Microphone (for AudioPilot®) | 12. Headrest cover |
| 13. Headrest frame front | 14. Headrest holder (free) | 15. Headrest holder (locked) |

FRONT SEAT

< REMOVAL AND INSTALLATION >

- | | | |
|--|--|---|
| 16. Seatback trim | 17. Seatback pad | 18. Seat cushion inner finisher inside (rear) |
| 19. Seat cushion inner finisher inside (front) | 20. Seat cushion inner finisher | 21. Seat cushion trim |
| 22. Seat cushion pad | 23. Seat cushion front finisher | 24. Front inner slide cover |
| 25. Seat A/C control unit | 26. Front outer slide cover | 27. Seat control unit |
| 28. Seat slide outer finisher (outside) | 29. Seat control switch | 30. Seat slide and lifter switch knob |
| 31. Seat reclining switch knob | 32. Seat cushion outer finisher | 33. Lumber support switch |
| 34. Seat cushion outer finisher inside (rear) | 35. Seat cushion outer finisher inside (front) | 36. Seat slide outer finisher (inside) |
| 37. Rear outer slide cover | 38. Seat harness | 39. Side air bag module |
| 40. Walk-in lever | 41. Walk-in lever lower escutcheon | 42. Walk-in lever upper escutcheon |
| 43. Walk-in lever cap | 44. Seatback board grille | 45. Seatback board |
| 46. Seatback board clip | 47. Seatback silencer | 48. Reclining device inner cover (outside) |
| 49. Seat belt buckle | 50. Seat slide inner finisher | 51. Seat cushion frame |
| 52. Seat cushion thermal electric device | 53. Rear inner slide cover | 54. Seat cushion A/C duct |
| 55. Seat cushion blower unit | 56. Seat cushion A/C filter | 57. Seatback lower panel |
| 58. Push nut | 59. Reclining device wire | 60. Seatback blower unit |
| 61. Seatback A/C filter | 62. Seatback thermal electric device | 63. Seatback thermal electric device bracket |
| 64. Seatback frame | 65. Reclining device inner cover (inside) | 66. Reclining device outer cover (inside) |
| 67. Reclining device outer cover (outside) | | |

Refer to [GI-4. "Components"](#) for symbols in the figure.

PASSENGER'S SEAT

FRONT SEAT

< REMOVAL AND INSTALLATION >

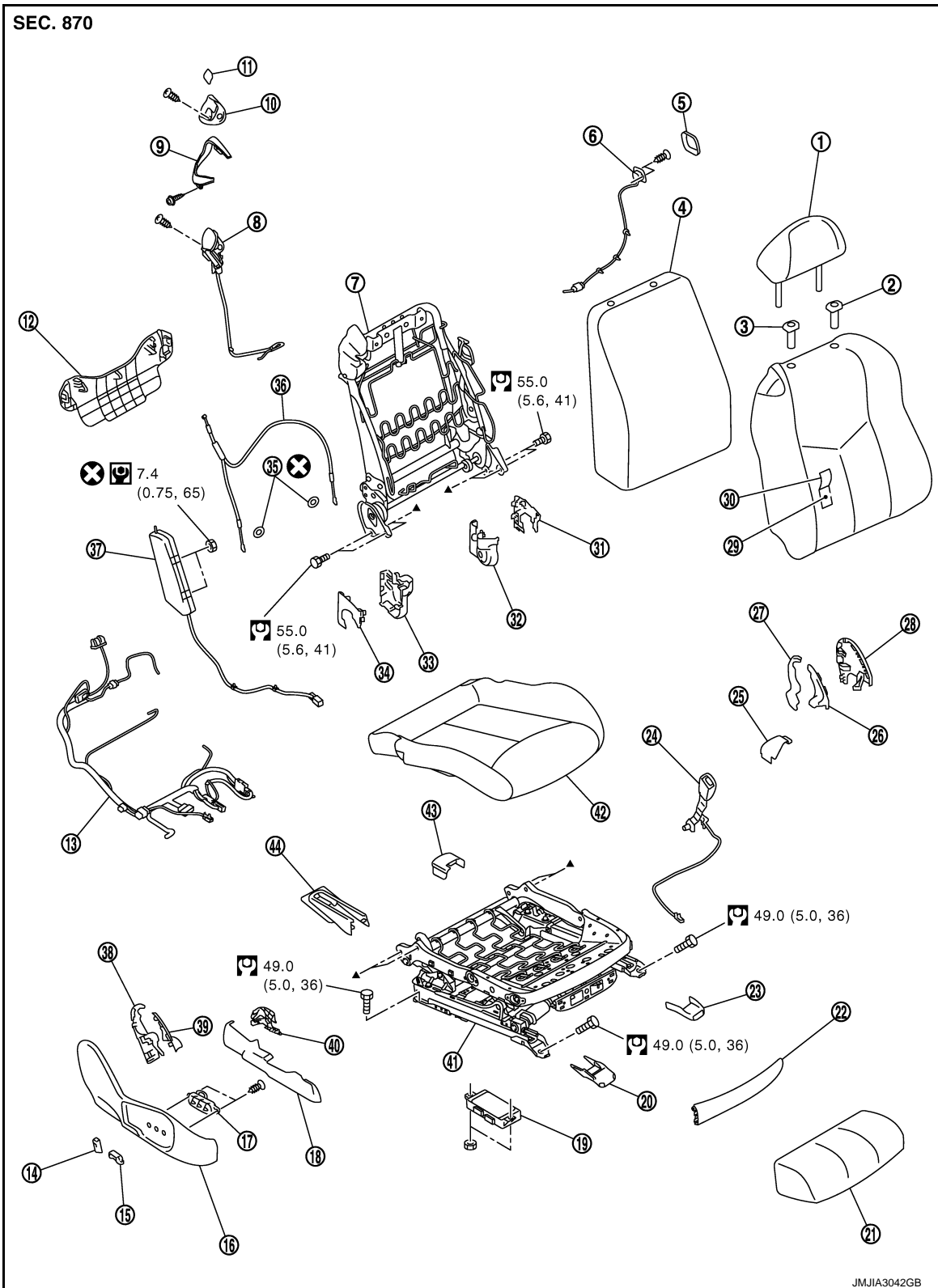

- | | | |
|------------------------------------|--------------------------------|---------------------------------------|
| 1. Headrest | 2. Headrest holder (locked) | 3. Headrest holder (free) |
| 4. Seatback silencer | 5. Slide switch escutcheon | 6. Slide switch (seatback) |
| 7. Seatback frame | 8. Walk-in lever | 9. Walk-in lever lower escutcheon |
| 10. Walk-in lever upper escutcheon | 11. Walk-in lever cap | 12. Seatback lower panel |
| 13. Seat harness | 14. Seat reclining switch knob | 15. Seat slide and lifter switch knob |
| 16. Seat cushion outer finisher | 17. Seat control switch | 18. Seat slide outer finisher |

A
B
C
D
E
F
G
H
I
SE
K
L
M
N
O
P

FRONT SEAT

< REMOVAL AND INSTALLATION >

- | | | |
|--|--|--|
| 19. Seat control unit | 20. Front outer slide cover | 21. Seat cushion pad (front) |
| 22. Seat cushion front finisher | 23. Front inner slide cover | 24. Seat belt buckle |
| 25. Seat slide inner finisher | 26. Seat cushion inner finisher inside (front) | 27. Seat cushion inner finisher inside (rear) |
| 28. Seat cushion inner finisher | 29. Seatback pad | 30. Seatback trim |
| 31. Reclining device inner cover (outside) | 32. Reclining device inner cover (inside) | 33. Reclining device outer cover (inside) |
| 34. Reclining device outer cover (outside) | 35. Push nut | 36. Reclining device wire |
| 37. Side air bag module | 38. Seat cushion outer finisher inside (rear) | 39. Seat cushion outer finisher inside (front) |
| 40. Seat slide outer finisher (inside) | 41. Seat cushion frame | 42. Seat cushion trim & pad |
| 43. Rear inner slide cover | 44. Rear outer slide cover | |

Refer to [GI-4, "Components"](#) for symbols in the figure.

PASSENGER'S SEAT WITH HEAD REST SPEAKER

FRONT SEAT

< REMOVAL AND INSTALLATION >

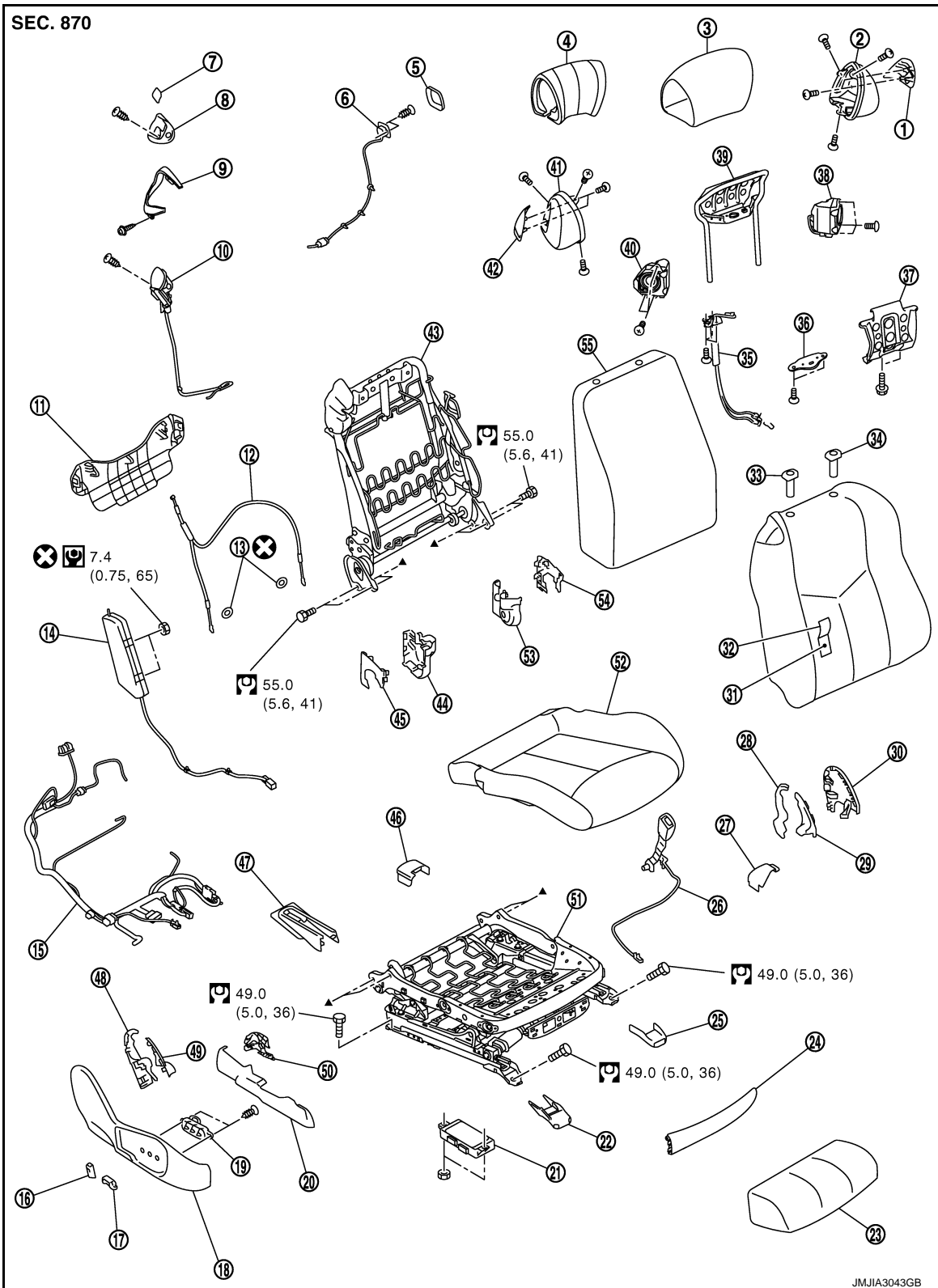

- | | | |
|--------------------------------|---------------------------------------|-----------------------------------|
| 1. Headrest inner escutcheon | 2. Headrest inner grille | 3. Headrest trim cover |
| 4. Headrest pad | 5. Slide switch escutcheon | 6. Slide switch (seatback) |
| 7. Walk-in lever cap | 8. Walk-in lever upper escutcheon | 9. Walk-in lever lower escutcheon |
| 10. Walk-in lever | 11. Seatback lower panel | 12. Reclining device wire |
| 13. Push nut | 14. Side air bag module | 15. Seat harness |
| 16. Seat reclining switch knob | 17. Seat slide and lifter switch knob | 18. Seat cushion outer finisher |

A
B
C
D
E
F
G
H
I
SE
K
L
M
N
O
P

FRONT SEAT

< REMOVAL AND INSTALLATION >

- | | | |
|--|--|---|
| 19. Seat control switch | 20. Seat slide outer finisher | 21. Seat control unit |
| 22. Front outer slide cover | 23. Seat cushion pad (front) | 24. Seat cushion front finisher |
| 25. Front inner slide cover | 26. Seat belt buckle | 27. Seat slide inner finisher |
| 28. Seat cushion inner finisher inside (rear) | 29. Seat cushion inner finisher inside (front) | 30. Seat cushion inner finisher |
| 31. Seatback pad | 32. Seatback trim | 33. Headrest holder (free) |
| 34. Headrest holder (locked) | 35. Headrest harness | 36. Headrest cover |
| 37. Headrest frame front | 38. Passenger headrest inner speaker | 39. Headrest frame |
| 40. Passenger headrest outer speaker | 41. Headrest outer grille | 42. Headrest outer escutcheon |
| 43. Seatback frame | 44. Reclining device outer cover (inside) | 45. Reclining device outer cover (outside) |
| 46. Rear inner slide cover | 47. Rear outer slide cover | 48. Seat cushion outer finisher inside (rear) |
| 49. Seat cushion outer finisher inside (front) | 50. Seat slide outer finisher (inside) | 51. Seat cushion frame |
| 52. Seat cushion trim & pad | 53. Reclining device inner cover (inside) | 54. Reclining device inner cover (outside) |
| 55. Seatback silencer | | |

Refer to [GI-4, "Components"](#) for symbols in the figure.

PASSENGER'S SEAT WITH HEADREST SPEAKER AND AIR CONDITIONER

FRONT SEAT

< REMOVAL AND INSTALLATION >

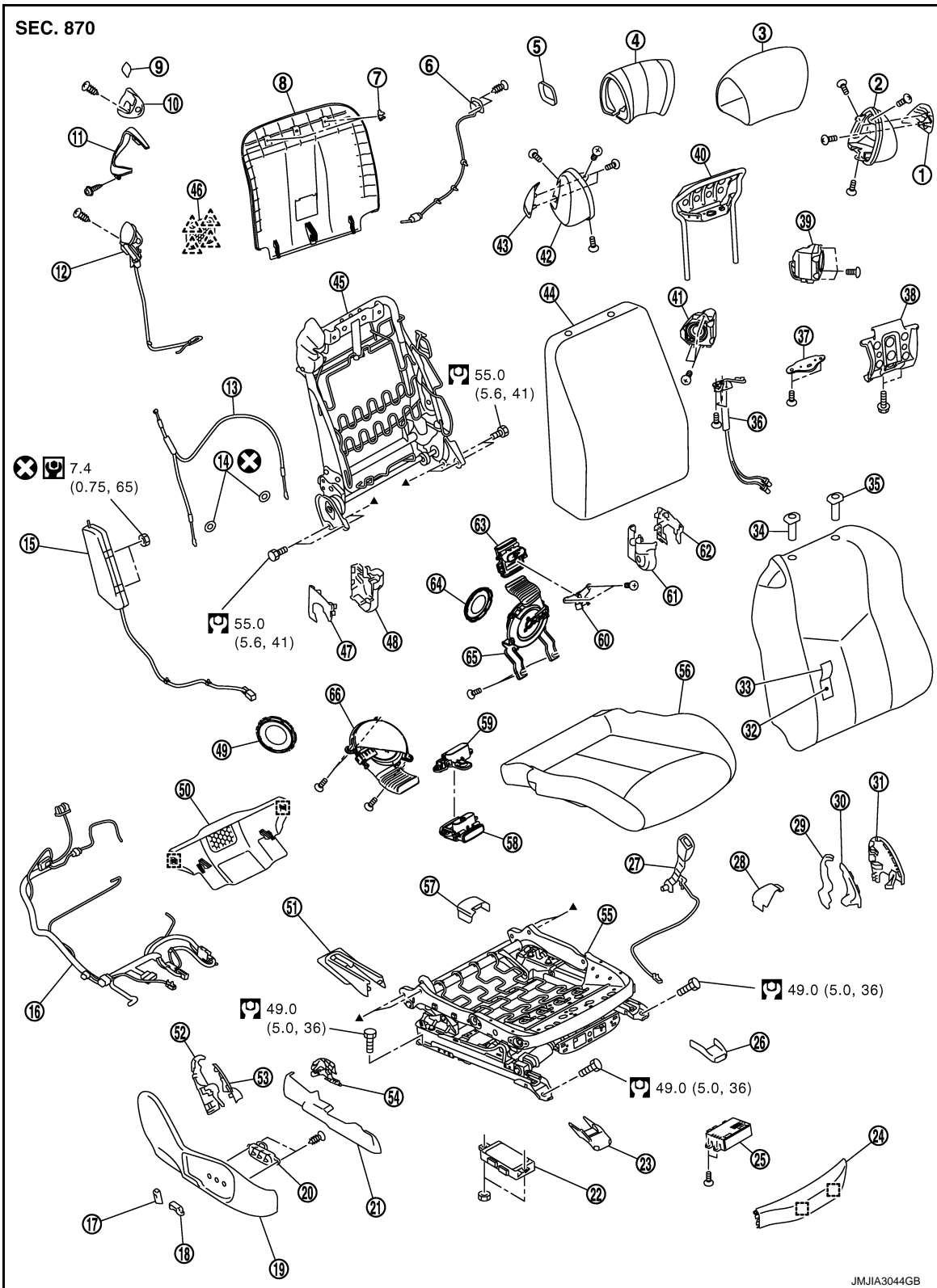

- | | | |
|------------------------------------|------------------------------------|---------------------------------------|
| 1. Headrest inner escutcheon | 2. Headrest inner grille | 3. Headrest trim cover |
| 4. Headrest pad | 5. Slide switch escutcheon | 6. Slide switch (seatback) |
| 7. Seatback board clip | 8. Seatback board | 9. Walk-in lever cap |
| 10. Walk-in lever upper escutcheon | 11. Walk-in lever lower escutcheon | 12. Walk-in lever |
| 13. Reclining device wire | 14. Push nut | 15. Side air bag module |
| 16. Seat harness | 17. Seat reclining switch knob | 18. Seat slide and lifter switch knob |

A
B
C
D
E
F
G
H
I
SE
K
L
M
N
O
P

FRONT SEAT

< REMOVAL AND INSTALLATION >

- | | | |
|---|--|--|
| 19. Seat cushion outer finisher | 20. Seat control switch | 21. Seat slide outer finisher |
| 22. Seat control unit | 23. Front outer slide cover | 24. Seat cushion front finisher |
| 25. Seat A/C control unit | 26. Front inner slide cover | 27. Seat belt buckle |
| 28. Seat slide inner finisher | 29. Seat cushion inner finisher inside (rear) | 30. Seat cushion inner finisher inside (front) |
| 31. Seat cushion inner finisher | 32. Seatback pad | 33. Seatback trim |
| 34. Headrest holder (free) | 35. Headrest holder (locked) | 36. Headrest harness |
| 37. Headrest cover | 38. Headrest frame front | 39. Passenger headrest inner speaker |
| 40. Headrest frame | 41. Passenger headrest outer speaker | 42. Headrest outer grille |
| 43. Headrest outer escutcheon | 44. Seatback silencer | 45. Seatback frame |
| 46. Seatback board grille | 47. Reclining device outer cover (outside) | 48. Reclining device outer cover (inside) |
| 49. Seat cushion A/C filter | 50. Seatback lower panel | 51. Rear outer slide cover |
| 52. Seat cushion outer finisher inside (rear) | 53. Seat cushion outer finisher inside (front) | 54. Seat slide outer finisher (inside) |
| 55. Seat cushion frame | 56. Seat cushion trim & pad | 57. Rear inner slide cover |
| 58. Seat cushion thermal electric device | 59. Seat cushion A/C duct | 60. Seatback thermal electric device bracket |
| 61. Reclining device inner cover (inside) | 62. Reclining device inner cover (outside) | 63. Seatback thermal electric device |
| 64. Seatback A/C filter | 65. Seatback blower unit | 66. Seat cushion blower unit |

Refer to [GI-4, "Components"](#) for symbols in the figure.

Removal and Installation

INFOID:000000008158219

REMOVAL

CAUTION:

When removing and installing, use shop cloths to protect parts from damage.

1. Remove the front slide cover.

a. Front outer slide cover

- Slide the seat to the rearmost position.
- Pull up the front edge of the front slide cover to release the pawls.
- Slide the front slide cover forward to release the pawls.

 : Pawl

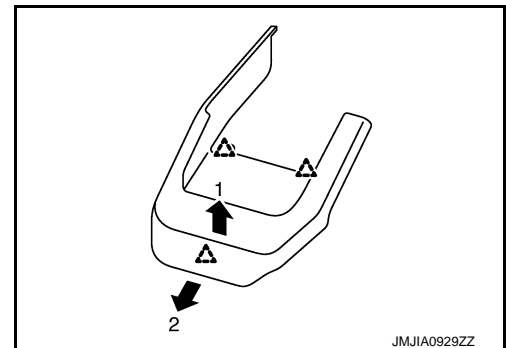

JMJIA0929ZZ

b. Front inner slide cover

- Slide the seat to the rearmost position.
- Pull up the front edge of the front slide cover to release the pawls.
- Slide the front slide cover forward to release the pawls.

 : Pawl

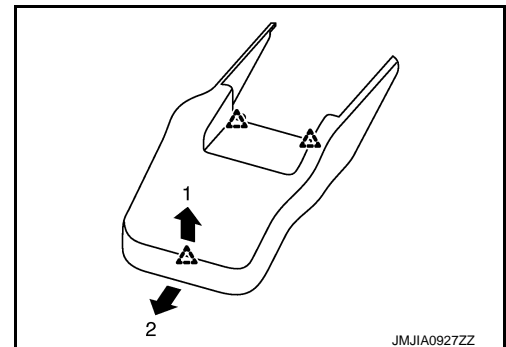

JMJIA0927ZZ

2. Remove the mounting bolts on the front side of the front seat.

3. Remove the rear slide cover.

FRONT SEAT

< REMOVAL AND INSTALLATION >

- a. Rear outer slide cover
- Slide the seat to the foremost position.
 - Pull up the rear edge of the rear outer slide cover to release the pawls.
 - Open the front end of the rear outer slide cover to release the pawls.

 : Pawl

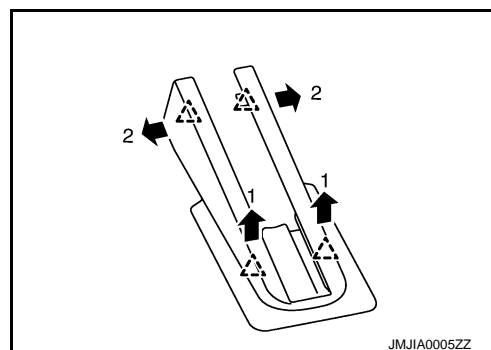

- b. Rear inner slide cover
- Slide the seat to the foremost position.
 - Pull up the rear edge of the rear inner slide cover to release the pawls.
 - Slide the rear inner slide cover rearward to release the pawls.

 : Pawl

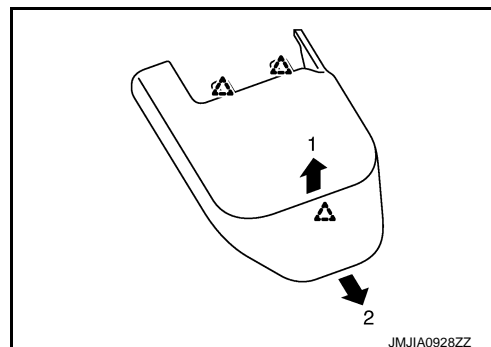

4. Remove the mounting bolts on the rear side of the front seat.
5. Set seatback in a standing position.

6. Disconnect harness connectors under the seat and remove harness securing clips.

CAUTION:

Before removal, turn ignition switch OFF, disconnect battery negative terminal and then wait for at least 3 minutes.

7. Remove seat from the vehicle.

CAUTION:

When removing and installing, use shop cloths to protect parts from damage.

INSTALLATION

Install in the reverse order of removal.

CAUTION:

- **Before installation, turn ignition switch OFF, disconnect battery negative terminal and then wait for at least 3 minutes.**
- **Clamp the harness in position.**

NOTE:

After installing the front seat, perform additional service when removing battery negative terminal. (with automatic drive positioner models) Refer to [ADP-9, "ADDITIONAL SERVICE WHEN REMOVING BATTERY NEGATIVE TERMINAL : Special Repair Requirement"](#). (without automatic drive positioner models) Refer to [SE-9, "ADDITIONAL SERVICE WHEN REMOVING BATTERY NEGATIVE TERMINAL : Special Repair Requirement"](#).

Disassembly and Assembly

INFOID:000000008158220

SEATBACK

Disassembly

1. Remove the seat cushion outer finisher.

FRONT SEAT

< REMOVAL AND INSTALLATION >

- Remove the metal clips, clips and pawls, and then pull out seat cushion outer finisher.

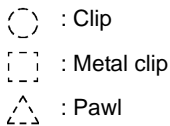

- Disconnect the seat control switch, lumbar support switch (except for driver side seat with air conditioner) and side support switch (with side support seat only) harness connector.

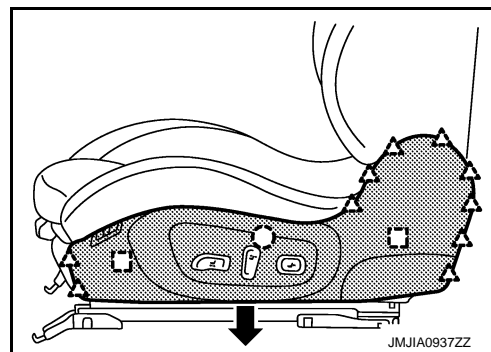

- Remove the seat cushion outer finisher inside (front, rear).

2. Remove the seat cushion inner finisher.

- Remove the seat cushion inner finisher inside (front, rear) by releasing the metal clip and pull it up together with the cover.
- Remove the seat cushion inner finisher inside (front, rear) from the seat cushion inner finisher by releasing the pawls.

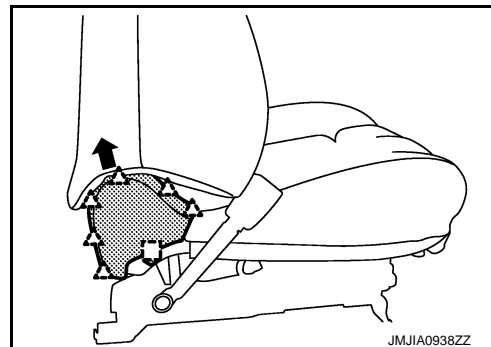
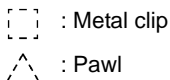

3. Remove the lumbar support lever knob. (with manual lumbar support seat only.)

- Pull snap ring (1) upward, and remove lumbar support lever knob (2) from seatback frame. Using a hook and pick tool.

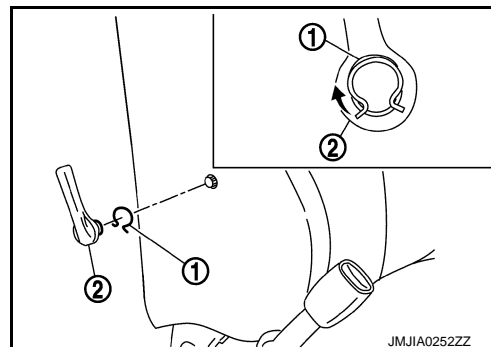

4. Remove the seatback trim and seatback pad.

- Remove the pawls, and then pull out slide switch escutcheon (1) (passenger's seat only).

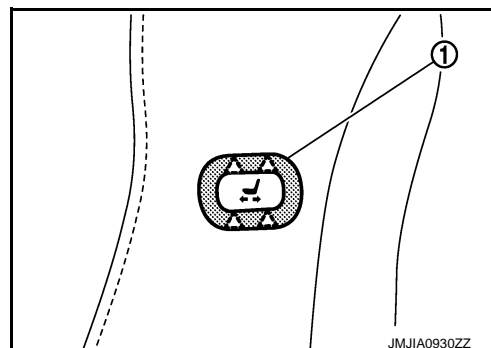
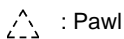

- Remove seatback board.

FRONT SEAT

< REMOVAL AND INSTALLATION >

 : Clip

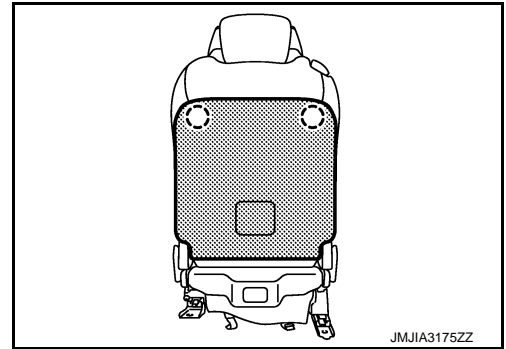

- Remove the seatback lower panel.

 : Metal clip

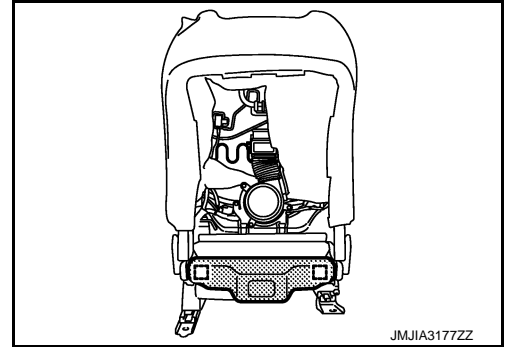

- Disconnect headrest speaker harness connector (A). (except seat without headrest speaker.)

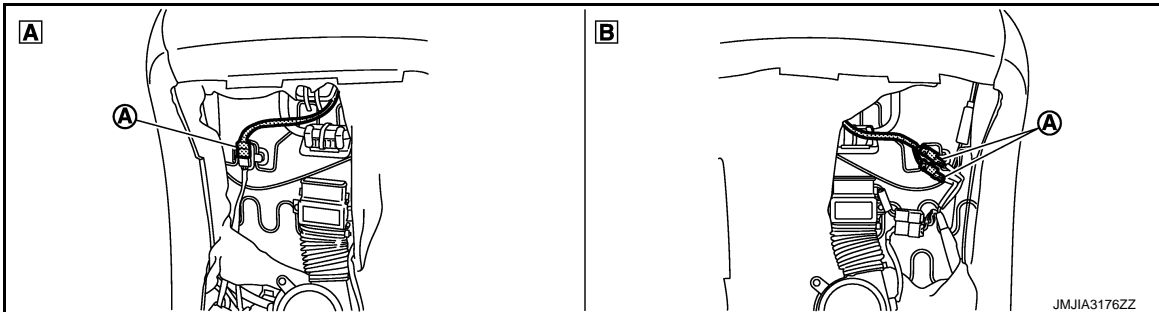

- (A) : Driver seat
(B) : Passenger seat

- Remove headrest.
- Remove headrest holders.

CAUTION:

**Before installing headrest holder check its orientation.
(front/rear and right/left)**

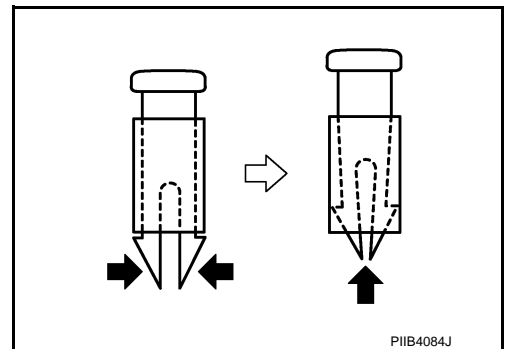

- Remove side air bag module.
- Remove the walk-in lever cap.

A
B
C
D
E
F
G
H
I
SE
K
L
M
N
O
P

FRONT SEAT

< REMOVAL AND INSTALLATION >

- Remove the screw (A) and pawls, and then walk-in lever upper escutcheon (2).

 : Pawl

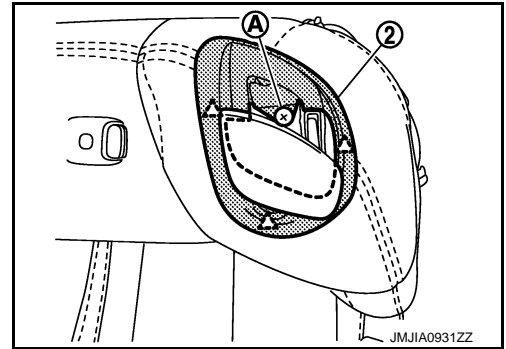

- Remove the screw (B), and then pull the seatback trim from the walk-in lever (3).

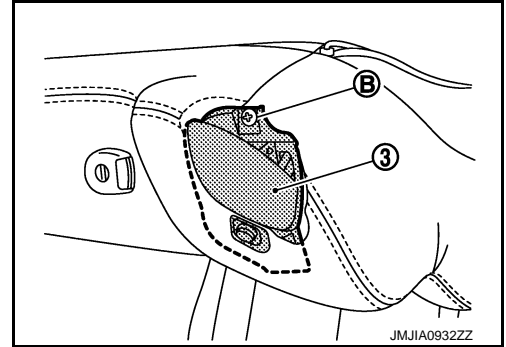

- Remove the walk-in lever lower escutcheon.
- Remove the seatback trim and seatback pad from the seatback frame.
- Remove the hog rings, and separate the seatback trim and seatback pad.

5. Remove the seatback silencer.

6. Remove seatback air conditioner unit. (except seat without air conditioner.)

- Disconnect harness connectors (A).
- Remove seatback air conditioner unit mounting screws (B).

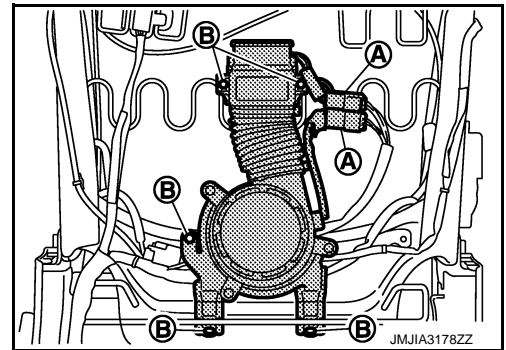

7. Disconnect the harness connectors.

8. Remove the side support bag and unit. (with side support seats only.)

- Remove the pawls, and then remove side support bag (1).
- Remove the side support unit.

 : Pawl

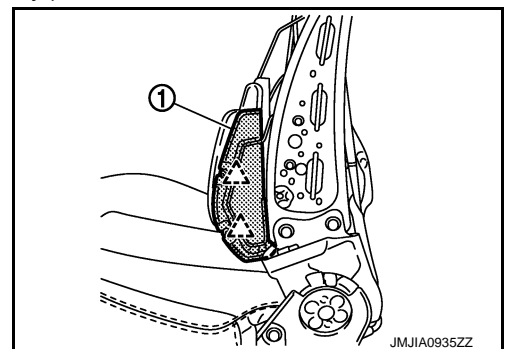

9. Remove the seatback frame.

FRONT SEAT

< REMOVAL AND INSTALLATION >

Remove the seatback frame mounting bolts (A).

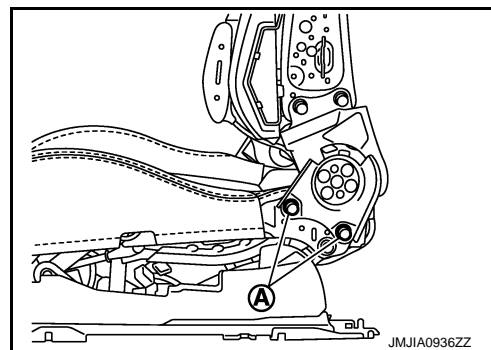

10. Remove the reclining device outer cover (front, rear).
11. Remove the reclining device inner cover (front, rear).
12. Remove the reclining device wire.
 - Remove the push nut (1).
 - Remove the reclining device wire (2) from the seatback frame and walk-in lever.

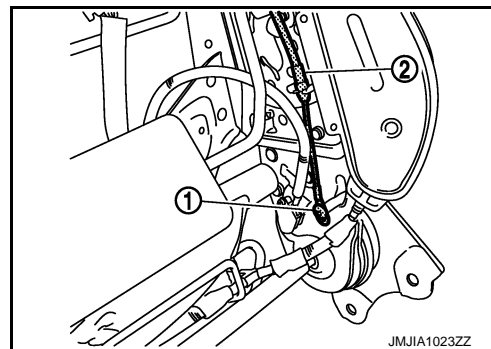

13. Remove the walk-in lever.

Assembly

Assemble in the reverse order of disassembly.

CAUTION:

Install the hog rings of seatback trim in position, and then securely connect the trim or trim cord with the pad side wire.

SEAT CUSHION

Disassembly

CAUTION:

- **Never disassemble front passenger seat cushion assembly.**
- **Always replace as an assembly.**
- **For front passenger seat service parts, refer to the service part catalogue.**

1. Remove the seat cushion outer finisher.
 - Remove the metal clips, clips and pawls, and then pull out seat cushion outer finisher.

- : Clip
- : Metal clip
- △ : Pawl

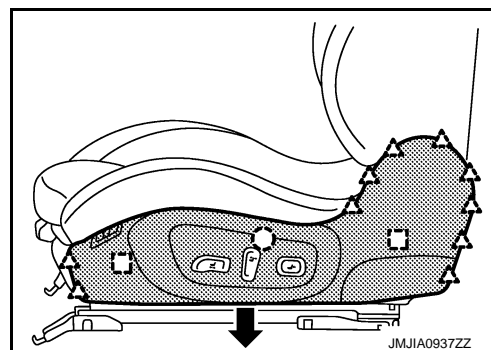

- Disconnect the seat control switch, lumbar support switch (except for driver side seat with air conditioner) and side support switch (with side support seat only) harness connector.
 - Remove the seat cushion outer finisher inside (front, rear).
2. Remove the seat cushion inner finisher.

FRONT SEAT

< REMOVAL AND INSTALLATION >

- Remove the seat cushion inner finisher inside (front, rear) by releasing the metal clip and pull it up together with the cover.
- Remove the seat cushion inner finisher inside (front, rear) from the seat cushion inner finisher by releasing the pawls.

 : Metal clip

 : Pawl

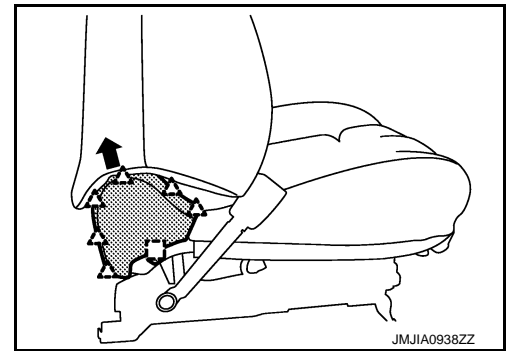

3. Remove the seat cushion front finisher.
Remove the metal clips, and then pull out seat cushion front finisher (1).

 : Metal clip

 : Pawl

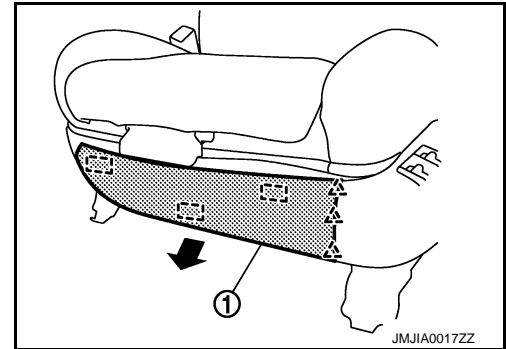

4. Remove seatback lower panel.

 : Metal clip

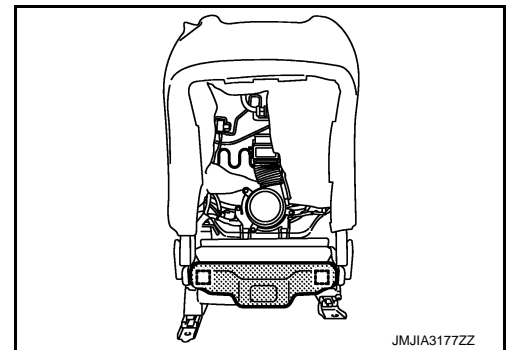

5. Disconnect harness connectors (A) and (B).
6. Remove side air bag harness connector fixing clips (C).
7. Remove side air bag harness fixing clamp (D).

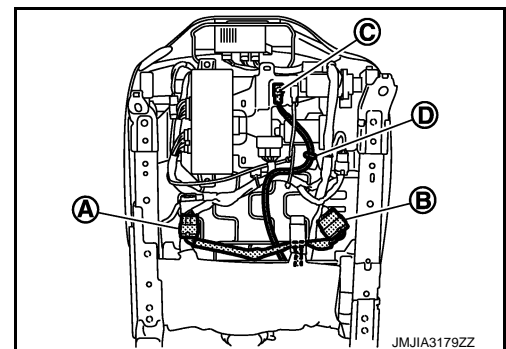

8. Remove seat cushion trim retainers and pull out harness (A) through the hole of seat cushion trim (B).

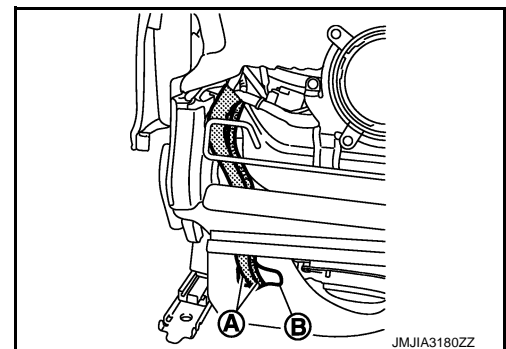

FRONT SEAT

< REMOVAL AND INSTALLATION >

9. Remove the seatback mounting bolts (A), and then remove the seatback assembly.

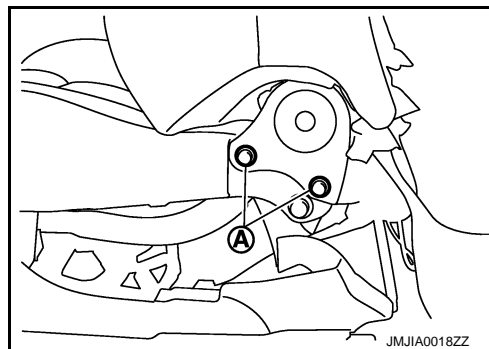

10. Remove seat cushion air conditioner unit. (except seat without air conditioner.)

- Disconnect harness connectors (A).
- Remove seatback air conditioner unit mounting screws (B).

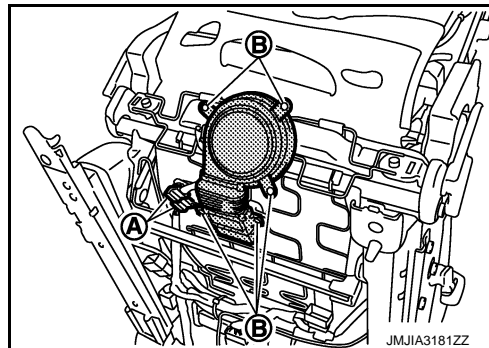

11. Remove the seat cushion pad (front). (Thigh extension model only.)

- Remove the retainer.
- Remove the seat cushion pad (front).

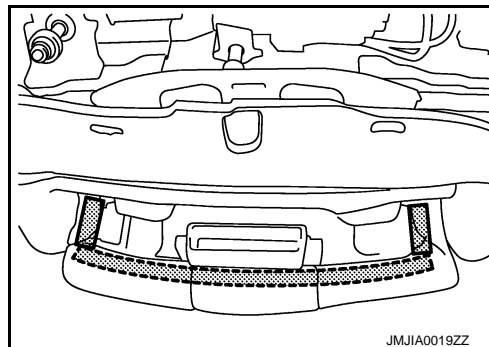

12. Remove the seat cushion trim and seat cushion pad.

- Remove the seat cushion trim wire (1) from the hook (2).

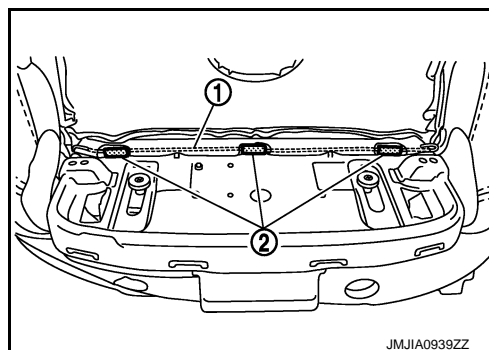

A
B
C
D
E
F
G
H
I
SE
K
L
M
N
O
P

FRONT SEAT

< REMOVAL AND INSTALLATION >

- Remove the clips (A).(Thigh extension model only.)

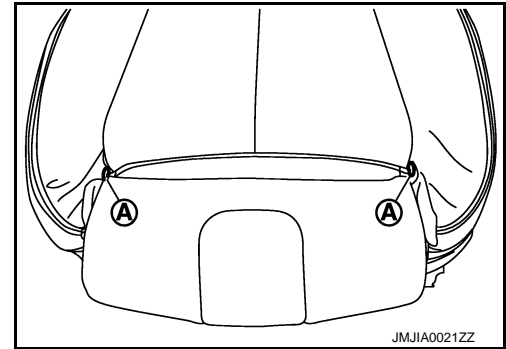

- Remove the seat cushion retainer.
- Disconnect the seat cushion heater unit harness connector.
- Remove the hog rings, and separate the seat cushion trim and seat cushion pad.

13. Remove the side support bag.(Side support model only.)

- Remove the hose clamp.
- Remove the pawls, and then remove side support bag (1).

 : Pawl

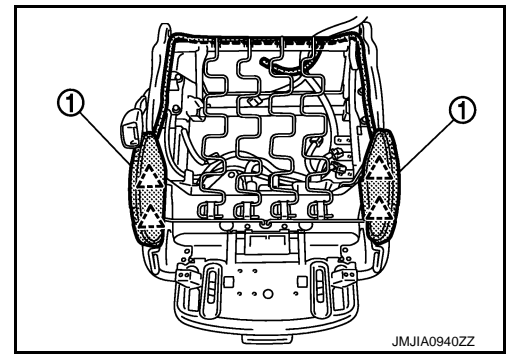

14. Remove the seat slide outer finisher.

- Remove the metal clip and pawls, and then pull out seat slide outer finisher (outside).
- Remove the metal clip, and then pull out seat slide outer finisher (inside).

 : Metal clip

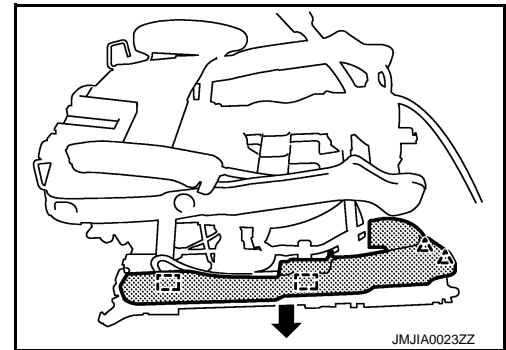

15. Remove the seat slide inner finisher.

Remove the metal clip, and then pull out seat slide inner finisher.

 : Metal clip

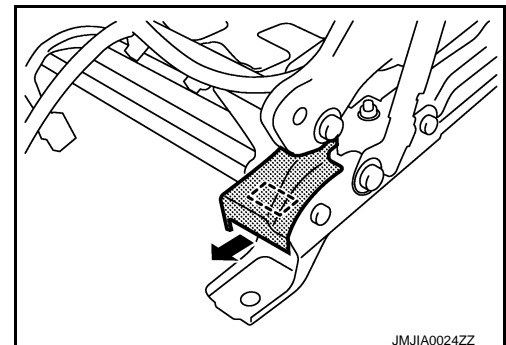

Assembly

1. Assemble in the reverse order of disassembly.

FRONT SEAT

< REMOVAL AND INSTALLATION >

CAUTION:

Install the hog rings of seat cushion trim in position, and then securely connect the trim or trim cord with the pad side wire.

2. Front seat switch harness layout.
- a. Normal seat without lumbar support switch

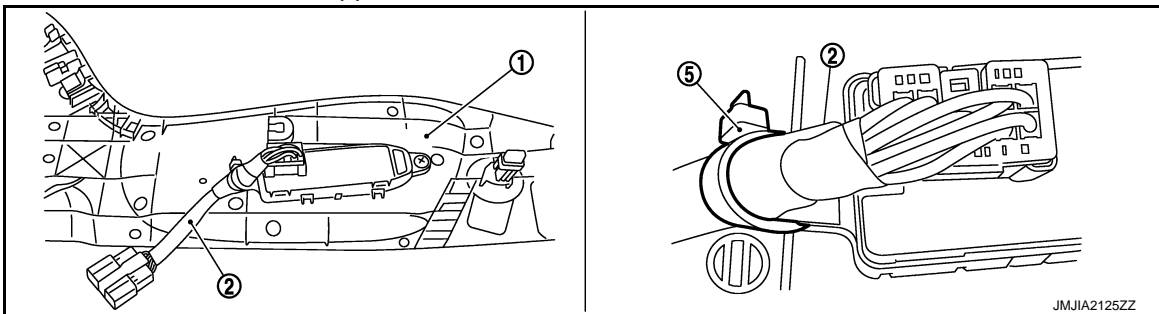

Fix seat control harness (2) to seat cushion outer finisher (1) boss using a self locking band (5) as shown in the figure.

- b. Normal seat with lumbar support switch

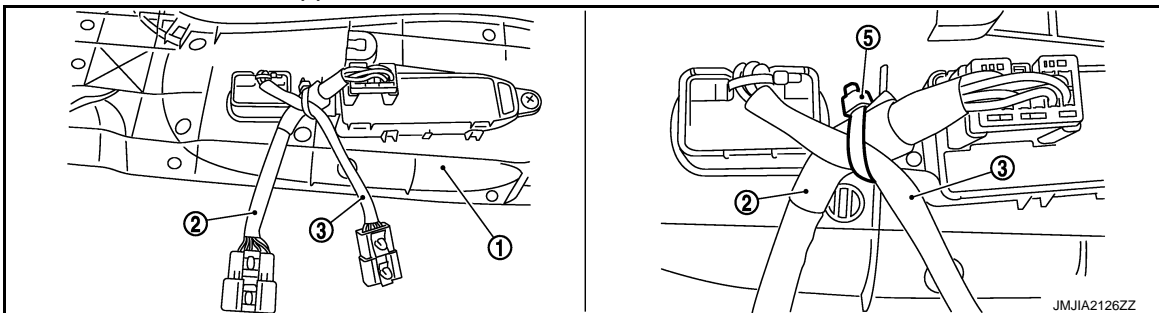

Locate lumbar support switch harness (3) in the forehead position, cross seat control harness (2), and fix to seat cushion outer finisher (1) boss using a self locking band (5) as shown in the figure.

- c. Sport seat without lumbar support switch

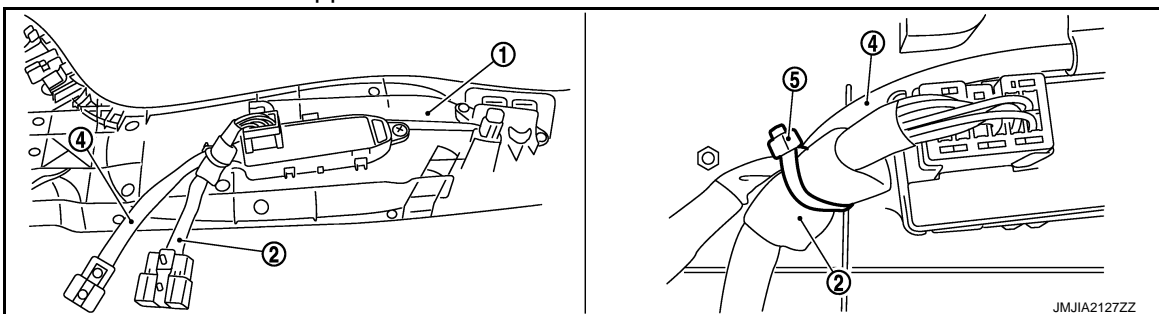

Locate side support switch harness (4) in the upper position of seat control harness (2) and fix to seat cushion outer finisher (1) boss using a self locking band (5) as shown in the figure.

- d. Sport seat with lumbar support switch

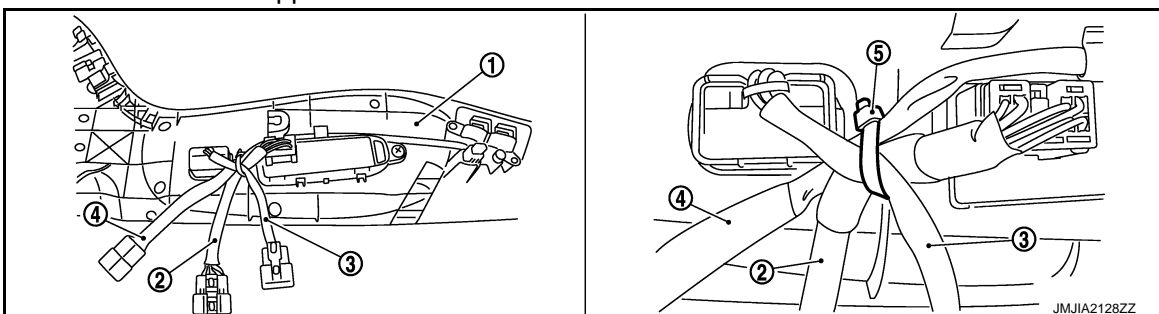

Locate side support switch harness (4) in the upper position of seat control harness (2). Locate lumbar support switch harness (3) crossing in the forehead position, and fix to seat cushion outer finisher (1) boss using a self locking band (5) as shown in the figure.

CAUTION:

A
B
C
D
E
F
G
H
I
K
L
M
N
O
P

SE

FRONT SEAT

< REMOVAL AND INSTALLATION >

- Adjust and fix that the ejected length (a) of harness is 10 mm (0.39 in) or less from the backside of connector for the seat control harness (2) switch side.
- Fix lumbar support switch harness (3) and side support switch harness (4) without slack.

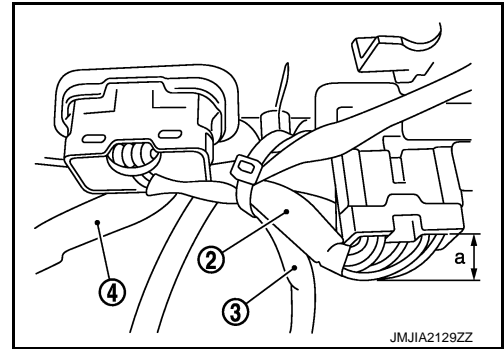

- Locate lumbar support switch harness crossing in the upper position, fix seat control harness connector (B), lumbar support switch harness connector (C), and side support harness connector (D) as shown in the figure.

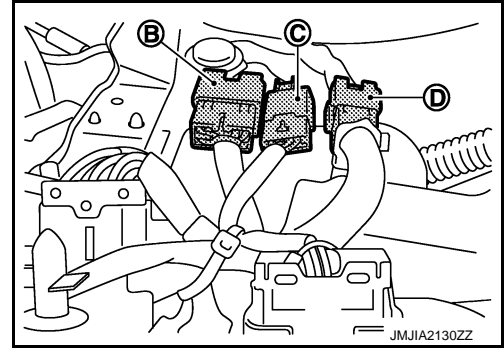

HEADREST (WITH HEADREST SPEAKER ONLY)

Disassembly

1. Remove headrest trim retainer (A), and then remove headrest trim cover.

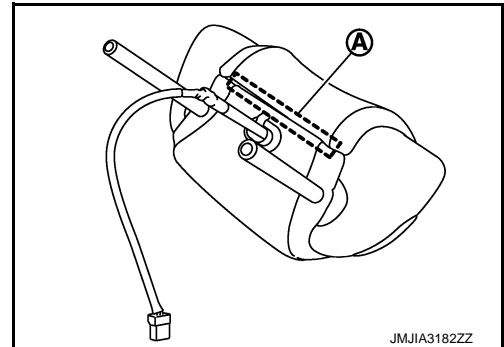

2. Remove headrest cover.
3. Remove headrest pad.
4. Remove mounting screws (A), and then remove headrest outer/inner grille.

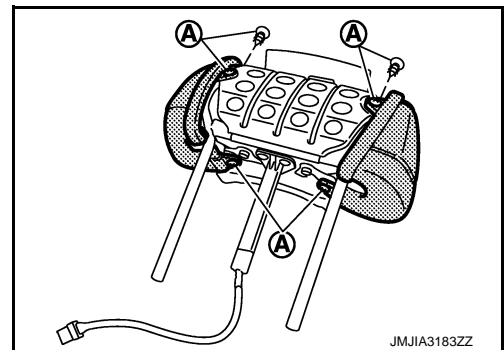

5. Remove following parts after removing headrest outer/inner grille.
 - Headrest outer/inner escutcheon.
 - Microphone (for AudioPilot®). Refer to [AV-383, "Removal and Installation"](#).

FRONT SEAT

< REMOVAL AND INSTALLATION >

6. Remove mounting bolts (A), and then headrest frame front.

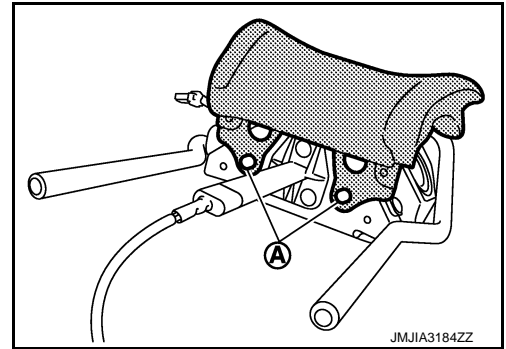

7. Remove headrest outer/inner speakers. Refer to [AV-381, "Removal and Installation"](#).

Assembly

Assembly in the reverse order of disassembly.

A
B
C
D
E
F
G
H
I
SE
K
L
M
N
O
P

REAR SEAT

< REMOVAL AND INSTALLATION >

REAR SEAT

Exploded View

INFOID:000000008158221

REAR SEAT

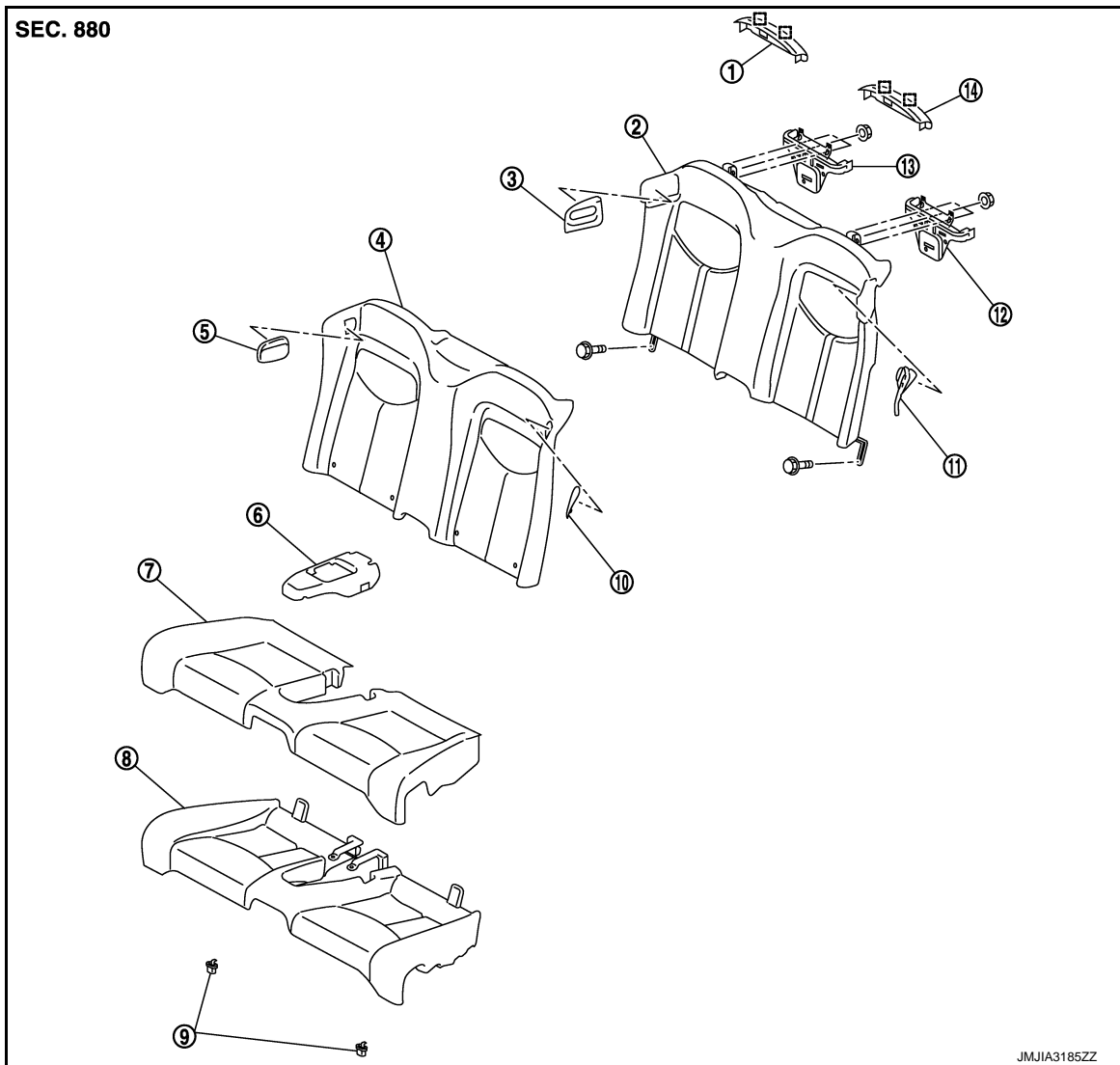

- | | | |
|----------------------------------|---------------------------------|----------------------------|
| 1. Pop-up roll bar cover (RH) | 2. Seatback pad | 3. Seatback inner bezel RH |
| 4. Seatback trim | 5. Rear seat belt escutcheon RH | 6. Seat cushion tray |
| 7. Seat cushion trim | 8. Seat cushion pad | 9. Seat cushion hook |
| 10. Rear seat belt escutcheon LH | 11. Seatback inner bezel LH | 12. Seatback bracket LH |
| 13. Seatback bracket RH | 14. Pop-up roll bar cover (LH) | |

 : Metal clip

Removal and Installation

INFOID:000000008158222

REMOVAL

CAUTION:

When removing and installing, use shop cloths to protect parts from damage.

1. Remove the seat cushion.

REAR SEAT

< REMOVAL AND INSTALLATION >

- Pull the seat cushion up, and then remove the seat cushion from the seat cushion hook.
- Remove the seat cushion from the vehicle.

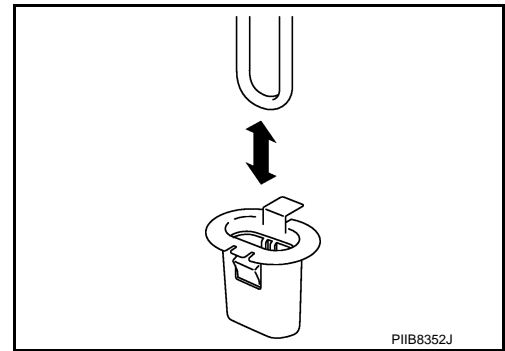

2. Remove the seatback.
 - Remove rear seat belt outer anchor mounting bolts (LH/RH).
 - Remove rear seatback mounting bolts (LH/RH).
 - Remove rear seat belt escutcheons (LH/RH).
 - Pull seatback up, and then remove seatback.

INSTALLATION

Install in the reverse order of removal.

CAUTION:

When removing and installing, use shop cloths to protect parts from damage.

Disassembly and Assembly

INFOID:000000008158223

SEATBACK

Disassembly

1. Remove the hog rings, and remove the seatback retainer.
2. Remove the hog rings to separate the seatback trim and seatback pad.
3. Remove seatback inner bezels (LH/RH).

Assembly

Assemble in the reverse order of disassembly.

CAUTION:

Install the hog rings of seatback trim in position, and then securely connect the trim or trim cord with the seatback frame.

SEAT CUSHION

Disassembly

1. Remove seat cushion tray.
Remove the clips (A) from the seat cushion backside, and then remove hook (B) when pulling seat cushion tray.

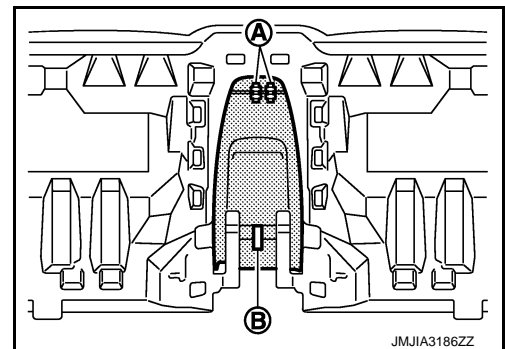

2. Remove the seat cushion trim and seat cushion pad.
Remove the hog rings to separate the seat cushion trim and seat cushion pad.

Assembly

Assemble in the reverse order of disassembly.

CAUTION:

Install the hog rings of seat cushion trim in position, and then securely connect the trim or trim cord with the seat cushion pad wire.

A
B
C
D
E
F
G
H
I
K
L
M
N
O
P

SE

DRIVER SEAT CONTROL UNIT

< REMOVAL AND INSTALLATION >

DRIVER SEAT CONTROL UNIT

Exploded View

INFOID:000000008158224

Refer to [SE-199. "Exploded View"](#).

Removal and Installation

INFOID:000000008158225

REMOVAL

CAUTION:

When removing and installing, use shop cloths to protect parts from damage.

1. Remove driver seat (1). Refer to [SE-210. "Removal and Installation"](#).
2. Remove mounting bolts (A).
3. Remove driver seat control unit (2).

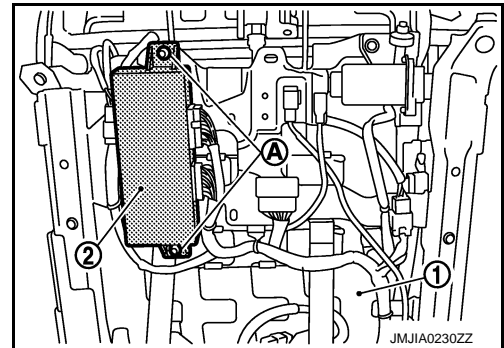

INSTALLATION

Install in the reverse order of removal.

CAUTION:

Always clamp the harness to the right place.

PASSENGER SEAT CONTROL UNIT

< REMOVAL AND INSTALLATION >

PASSENGER SEAT CONTROL UNIT

Exploded View

INFOID:000000008158226

Refer to [SE-199, "Exploded View"](#).

Removal and Installation

INFOID:000000008158227

REMOVAL

CAUTION:

When removing and installing, use shop cloths to protect parts from damage.

NOTE:

The same procedure is performed for driver side. Refer to [ADP-204, "Removal and Installation"](#).

INSTALLATION

Install in the reverse order of removal.

CAUTION:

Always clamp the harness to the right place.

A
B
C
D
E
F
G
H
I
K
L
M
N
O
P

SE

HEATED SEAT CONTROL UNIT

< REMOVAL AND INSTALLATION >

HEATED SEAT CONTROL UNIT

Exploded View

INFOID:000000008158228

Refer to [SE-199, "Exploded View"](#).

Removal and Installation

INFOID:000000008158229

REMOVAL

CAUTION:

When removing and installing, use shop cloths to protect parts from damage.

1. Remove the front seat.
2. Disconnect heated seat control unit connector.
3. Remove the heated seat control unit from the heated seat control unit stay. Refer to [SE-199, "Exploded View"](#).

INSTALLATION

Install in the reverse order of removal.

CAUTION:

Always clamp the harness to the right place.

POWER SEAT SWITCH

< REMOVAL AND INSTALLATION >

POWER SEAT SWITCH

Removal and Installation

INFOID:000000008158230

REMOVAL

CAUTION:

When removing and installing, use shop cloths to protect parts from damage.

NOTE:

The same procedure is performed for driver side and passenger side.

1. Remove the seat cushion outer finisher (1). Refer to [SE-210](#). "[Removal and Installation](#)".
2. Remove the screws (A).
3. Remove the power seat switch (2) from the seat cushion outer finisher.

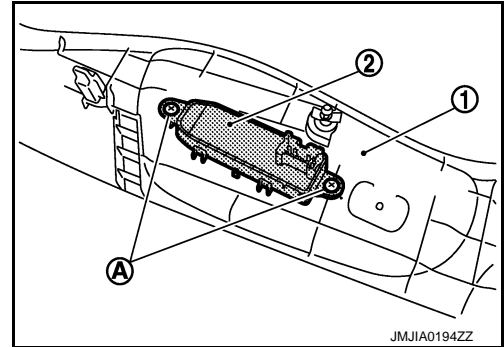

INSTALLATION

Install in the reverse order of removal.

CAUTION:

Always clamp the harness to the right place.

A
B
C
D
E
F
G
H
I
K
L
M
N
O
P

SE

SLIDING SWITCH

< REMOVAL AND INSTALLATION >

SLIDING SWITCH SEATBACK

SEATBACK : Removal and Installation

INFOID:000000008158231

REMOVAL

CAUTION:

When removing and installing, use shop cloths to protect parts from damage.

1. Remove seatback pad. Refer to [SE-210. "Removal and Installation"](#).
2. Remove screws (A).
3. Disconnect seat sliding switch (seatback) connector.
4. Remove seat sliding switch (seatback) (2) from seatback frame (1).

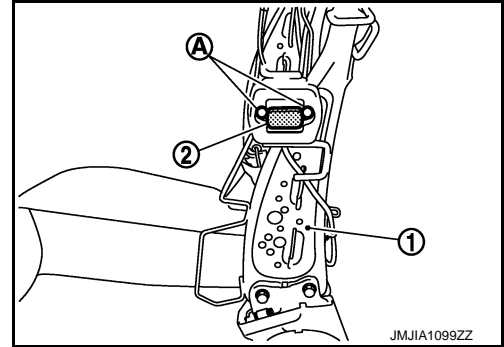

INSTALLATION

Install in the reverse order of removal.

CAUTION:

Always clamp the harness to the right place.

SIDE SUPPORT SWITCH

< REMOVAL AND INSTALLATION >

SIDE SUPPORT SWITCH

Removal and Installation

INFOID:000000008158232

REMOVAL

CAUTION:

When removing and installing, use shop cloths to protect parts from damage.

1. Remove seat cushion outer finisher (1). Refer to [SE-210, "Removal and Installation"](#).
2. Remove screws (A).
3. Remove side support switch (2) from seat cushion outer finisher.

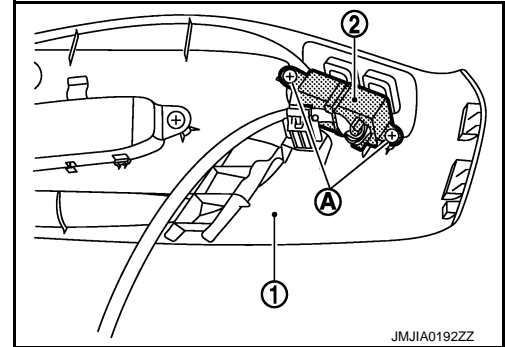

INSTALLATION

Install in the reverse order of removal.

CAUTION:

Always clamp the harness to the right place.

A
B
C
D
E
F
G
H
I
K
L
M
N
O
P

SE

LUMBAR SUPPORT SWITCH

< REMOVAL AND INSTALLATION >

LUMBAR SUPPORT SWITCH

Removal and Installation

INFOID:000000008158233

REMOVAL

CAUTION:

When removing and installing, use shop cloths to protect parts from damage.

1. Remove seat cushion outer finisher (1). Refer to [SE-210](#), "[Removal and Installation](#)".
2. Remove lumbar support switch (2).

 : Pawl

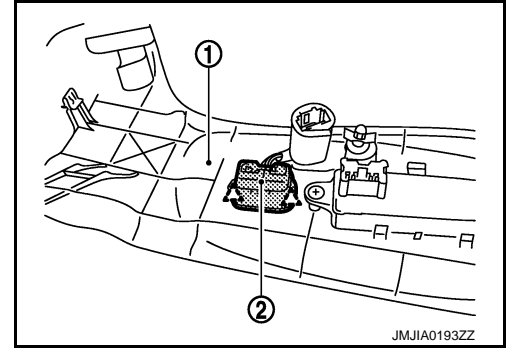

INSTALLATION

Install in the reverse order of removal.

CAUTION:

Always clamp the harness to the right place.

HEATED SEAT SWITCH

< REMOVAL AND INSTALLATION >

HEATED SEAT SWITCH

Exploded View

INFOID:000000008158234

Refer to [IP-35, "A/T MODELS : Exploded View"](#) (A/T models) or [IP-40, "M/T MODELS : Exploded View"](#) (M/T models).

Removal and Installation

INFOID:000000008158235

REMOVAL

CAUTION:

When removing and installing, use shop cloths to protect from damage.

1. Remove the console body assembly. Refer to [IP-36, "A/T MODELS : Removal and Installation"](#) (A/T models) or [IP-41, "M/T MODELS : Removal and Installation"](#) (M/T models).
2. Remove heated seat switch (1) from switch bracket (2) with remover tool (A).

 : Pawl

NOTE:

The same procedure is performed for passenger side.

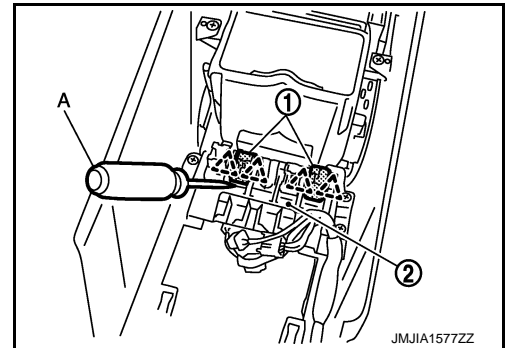

INSTALLATION

Install in the reverse order of removal.

A
B
C
D
E
F
G
H
I
K
L
M
N
O
P

SE

CLIMATE CONTROLLED SEAT SWITCH

< REMOVAL AND INSTALLATION >

CLIMATE CONTROLLED SEAT SWITCH

Exploded View

INFOID:000000008158236

Refer to [IP-35, "A/T MODELS : Exploded View"](#) (A/T models) or [IP-40, "M/T MODELS : Exploded View"](#) (M/T models).

Removal and Installation

INFOID:000000008158237

REMOVAL

CAUTION:

When removing and installing, use shop cloths to protect parts from damage.

1. Remove the console upper finisher, console finisher assembly, cup holder assembly and console switch finisher. Refer to [IP-36, "A/T MODELS : Removal and Installation"](#) (A/T models) or [IP-41, "M/T MODELS : Removal and Installation"](#) (M/T models).
2. Climate controlled seat switch (1) is removed from console switch finisher (2) using remover toolr (A).

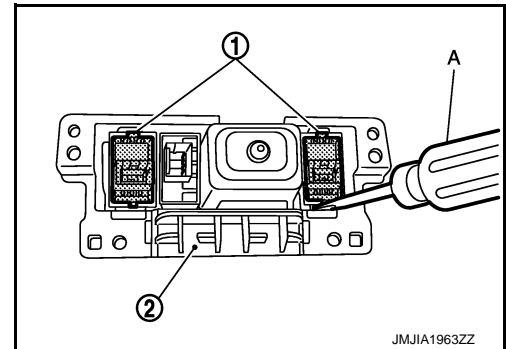

JMJIA1963ZZ

INSTALLATION

Install in the reverse order of removal.

CLIMATE CONTROLLED SEAT BLOWER FILTER

< REMOVAL AND INSTALLATION >

CLIMATE CONTROLLED SEAT BLOWER FILTER SEAT CUSHION

SEAT CUSHION : Exploded View

INFOID:000000008158238

Refer to [SE-199, "Exploded View"](#).

SEAT CUSHION : Removal and Installation

INFOID:000000008158239

REMOVAL

CAUTION:

When removing and installing, use shop cloths to protect parts from damage.

1. Remove the seat cushion rear finisher.
2. Turn blower filter (1) counter clockwise and remove it from climate controlled seat blower motor (2).

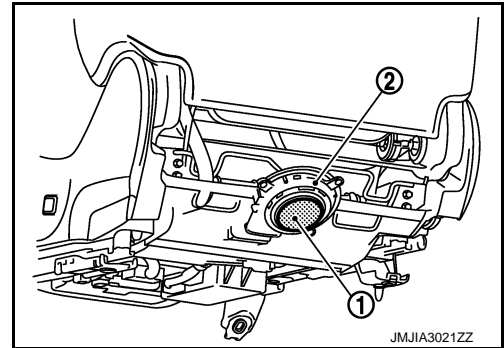

INSTALLATION

Install in the reverse order of removal.

SEATBACK

SEATBACK : Exploded View

INFOID:000000008158240

Refer to [SE-199, "Exploded View"](#).

SEATBACK : Removal and Installation

INFOID:000000008158241

REMOVAL

CAUTION:

When removing and installing, use shop cloths to protect parts from damage.

1. Remove the seatback escutcheon.
2. Turn blower filter (1) counter clockwise and remove it from climate controlled seat blower motor (2).

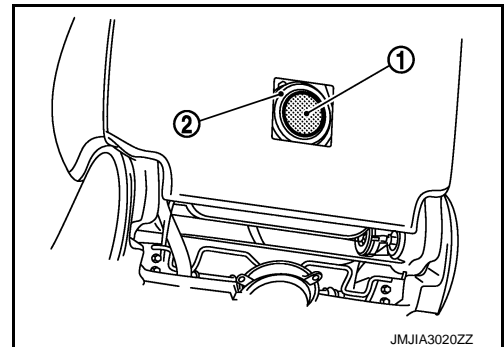

INSTALLATION

Install in the reverse order of removal.

A
B
C
D
E
F
G
H
I
SE
K
L
M
N
O
P